



CORPORATE HEADQUARTERS

P.O. BOX 2069, BELLINGHAM, WA, U.S.A.

TELEPHONE: (360) 647-0801 • FAX: (360) 676-1075

Introducing the Grizzly Model G0623X 10" Sliding Table Saw



MACHINE HIGHLIGHTS (see *Machine Data Sheet* for full specifications)

- 5 HP, 220V, single-phase motor.
- Compact 60" x 27½" footprint, yet has a 78½" maximum crosscutting capacity.
- 3⅛" Scoring blade for smooth, tearout-free cuts.
- 4" Cabinet mounted dust port and 2½" blade guard mounted dust port.
- Includes clamping miter fence, traditional rip fence, and two flip stops for the crosscut fence.

The Model G0623X is available for \$2,895.00. As with all Grizzly products, the Model G0623X is covered by a one-year warranty. For more information call 1-800-523-4777 or visit www.grizzly.com.



MACHINE DATA SHEET

Customer Service #: (570) 546-9663 · To Order Call: (800) 523-4777 · Fax #: (800) 438-5901

MODEL G0623X 10" SLIDING TABLESAW

Product Dimensions:

Weight..... 533 lbs.
 Length/Width/Height..... 76 x 124-3/4 x 46 in.
 Foot Print (Length/Width)..... 25-1/5 x 28 in.

Shipping Dimensions:

Carton #1

Type..... Wood Crate
 Content..... Machine
 Weight..... 570 lbs.
 Length/Width/Height..... 46 x 42 x 44 in.

Carton #2

Type..... Cardboard
 Content..... Sliding Table
 Weight..... 118 lbs.
 Length/Width/Height..... 67 x 18-1/2 x 10 in.

Electrical:

Power Requirement..... 220V, Single-Phase,
 Switch..... Magnetic with Thermal Overload Protection
 Switch Voltage..... 220V
 Minimum Circuit Size..... 30A
 Plug Included..... No
 Recommended Plug/Outlet Type..... L6-30

Motors:

Main

Type..... TEFC Capacitor Start Induction
 Horsepower..... 5 HP
 Voltage..... 220V
 Prewired..... 220V
 Phase..... Single
 Amps..... 22A
 Speed..... 3450 RPM
 Cycle..... 60 Hz
 Number Of Speeds..... 1
 Power Transfer V-Belt Drive
 Bearings..... Sealed and Lubricated

Main Specifications:

Operation Information

Main Blade Size.....	10 in.
Main Arbor Size.....	5/8 in.
Scoring Blade Size.....	3-1/8 in.
Scoring Blade Arbor Size.....	22 mm
Maximum Width of Dado.....	13/16 in.
Main Blade Tilt.....	0 - 45 deg.
Main Blade Speed.....	4000 RPM
Scoring Blade Tilt.....	0 - 45 deg.
Scoring Blade Speed.....	8000 RPM

Cutting Capacities

Max Depth Of Cut At 90D.....	3-1/8 in.
Max Depth Of Cut At 45D.....	2-1/4 in.
Table With Rip Fence Max Cut Width.....	33 in.
Sliding Table With Cross Fence Max Cut Width.....	78-1/2 in.
Sliding Table With Cross Fence Max Cut Length.....	63 in.
Miter Fence Cut Width At 45D.....	63 in.

Table Information

Floor To Table Height.....	33-5/8 in.
Table Size Length.....	27 in.
Table Size Width.....	14-3/8 in.
Table Size Thickness.....	2 in.
Table Size With Ext Wings Length.....	47 in.
Table Size With Ext Wings Width.....	40 in.
Table Size With Ext Wings Thickness.....	2 in.
Sliding Table Length.....	63 in.
Sliding Table Width.....	12-1/4 in.
Sliding Table Thickness.....	3-1/2 in.
Sliding Table T Slot Top Width.....	5/8 in.
Sliding Table T Slot Height.....	1/2 in.
Sliding Table T Slot Bottom Width.....	1-1/4 in.

Fence Information

Fence Type.....	Extruded Aluminum
Fence Size Length.....	33-1/2 in.
Fence Size Width.....	2 in.
Fence Size Height.....	4-1/4 in.
Fence Stops.....	2

Construction Materials

Table Construction.....	Cast Iron
Sliding Table Construction.....	Aluminum
Base Construction.....	Steel
Body Assembly Construction.....	Steel
Cabinet Construction.....	Steel
Trunnions Construction.....	Cast Iron
Fence Assembly Construction.....	Extruded Aluminum
Rails Construction.....	Hardened Steel
Guard Construction.....	Plastic
Spindle Bearing Type.....	Radial Ball Bearing 6004LLB
Paint.....	Powder Coating

Other Related Information

No Of Dust Ports.....	2
Dust Port Size.....	4, 2-1/2 in.

Other Specifications:

Country Of Origin Taiwan
Warranty 1 Year
Serial Number Location Machine ID Label on Front of Machine
Assembly Time 1-1/2 hrs.

Features:

- 4" Main Dust Port
- Adjustable Scoring Knife Kerf
- Adjustable Riving Knife
- Single Lever Locking Fence
- Blade Guard with 2-1/2" Dust Port
- Dadoes Up To 13/16"



SLIDING TABLE SAW CAPACITIES

Customer Service #: (570) 546-9663 • To Order Call: (800) 523-4777 • Fax #: (800) 438-5901

MODEL G0623X 10" SLIDING TABLE SAW

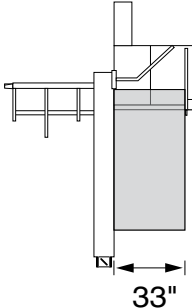
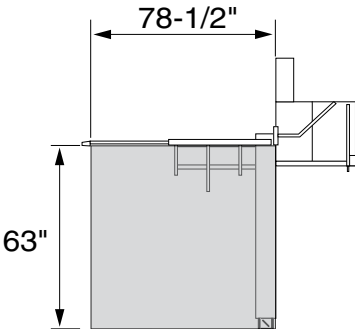
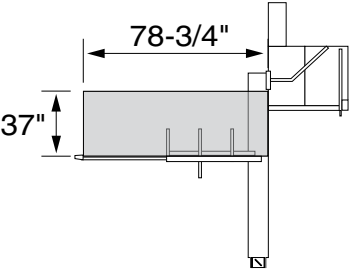
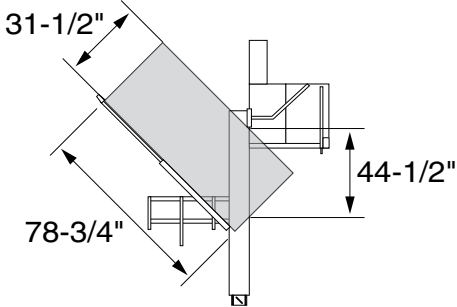
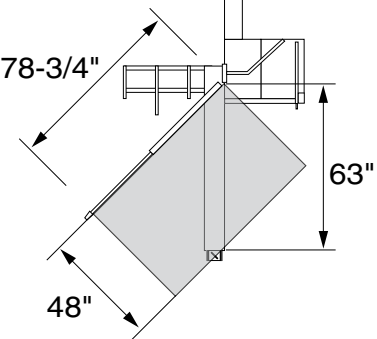
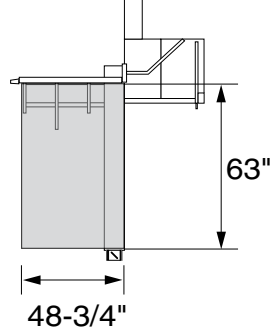
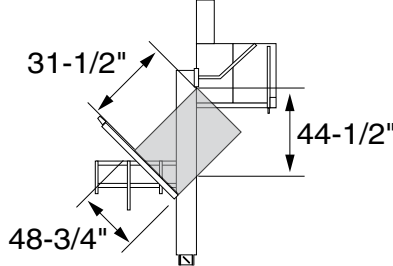
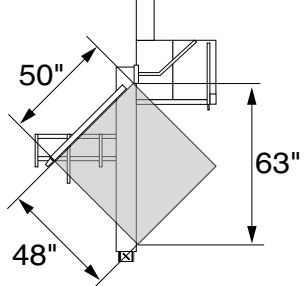
 <p>Ripping Width</p>	 <p>Cross Cut</p>
 <p>Miter Cut 90° (push cut)</p>	 <p>Miter Cut 45° (push cut)</p>
 <p>Miter Cut 45°</p>	 <p>Cross Cut (fence not extended)</p>
 <p>Miter Cut 45° (push cut, fence not extended)</p>	 <p>Miter Cut 45° (fence not extended)</p>