

G8145Z Cabinet Breakdown & Parts List

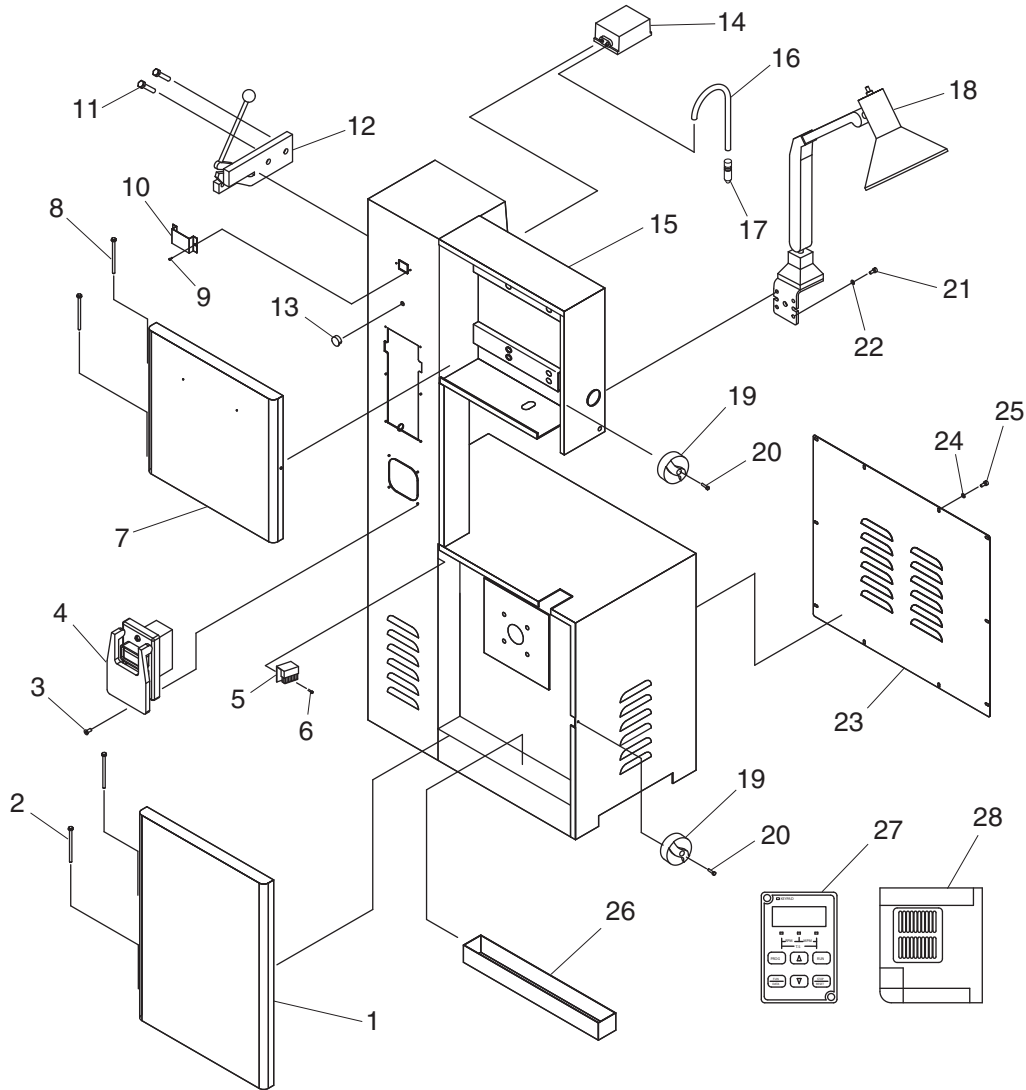

REF	PART #	DESCRIPTION
1	P8145Z001	WHEEL DOOR LOWER
2	P8144Z002	HINGE PIN LOWER
3	PS05M	PHLP HD SCR M5-.8 X 8
4	P8145Z004	ON/OFF SWITCH W/PADDLE
5	P8144Z005	BLADE CLEANING BRUSH
6	PS47M	PHLP HD SCR M6-1 X 25
7	P8145Z007	WHEEL DOOR UPPER
8	P8144Z002	HINGE PIN UPPER
9	PS05M	PHLP HD SCR M5-.8 X 8
10	P8144Z010	DIGITAL DISPLAY BRACKET
11	PSB11M	CAP SCREW M8-1.25 X 16
12	P8144Z012	BLADE SHEAR
13	P8144Z013	VARIABLE SPEED DIAL
14	P8144Z014	AIR PUMP

REF	PART #	DESCRIPTION
15	P8145Z015	BANDSAW CABINET
16	P8144Z016	AIR HOSE 4X6MM
17	P8144Z017	AIR NOZZLE
18	P8144Z018	WORK LAMP 220V
19	P8144Z019	DOOR KNOB
20	PS47M	PHLP HD SCR M6-1 X 25
21	PSB28M	CAP SCREW M6-1 X 15
22	PW03M	FLAT WASHER 6MM
23	P8145Z023	MOTOR ACCESS PANEL
24	PW03M	FLAT WASHER 6MM
25	PS68M	PHLP HD SCR M6-1 X 10
26	P8145Z026	CHIP PAN
27	P8144Z027	DIGITAL DISPLAY
28	P8145Z028	INVERTER RM5G 1-1/2HP 220V 3PH



G8145Z Table & Guides Breakdown & Parts List

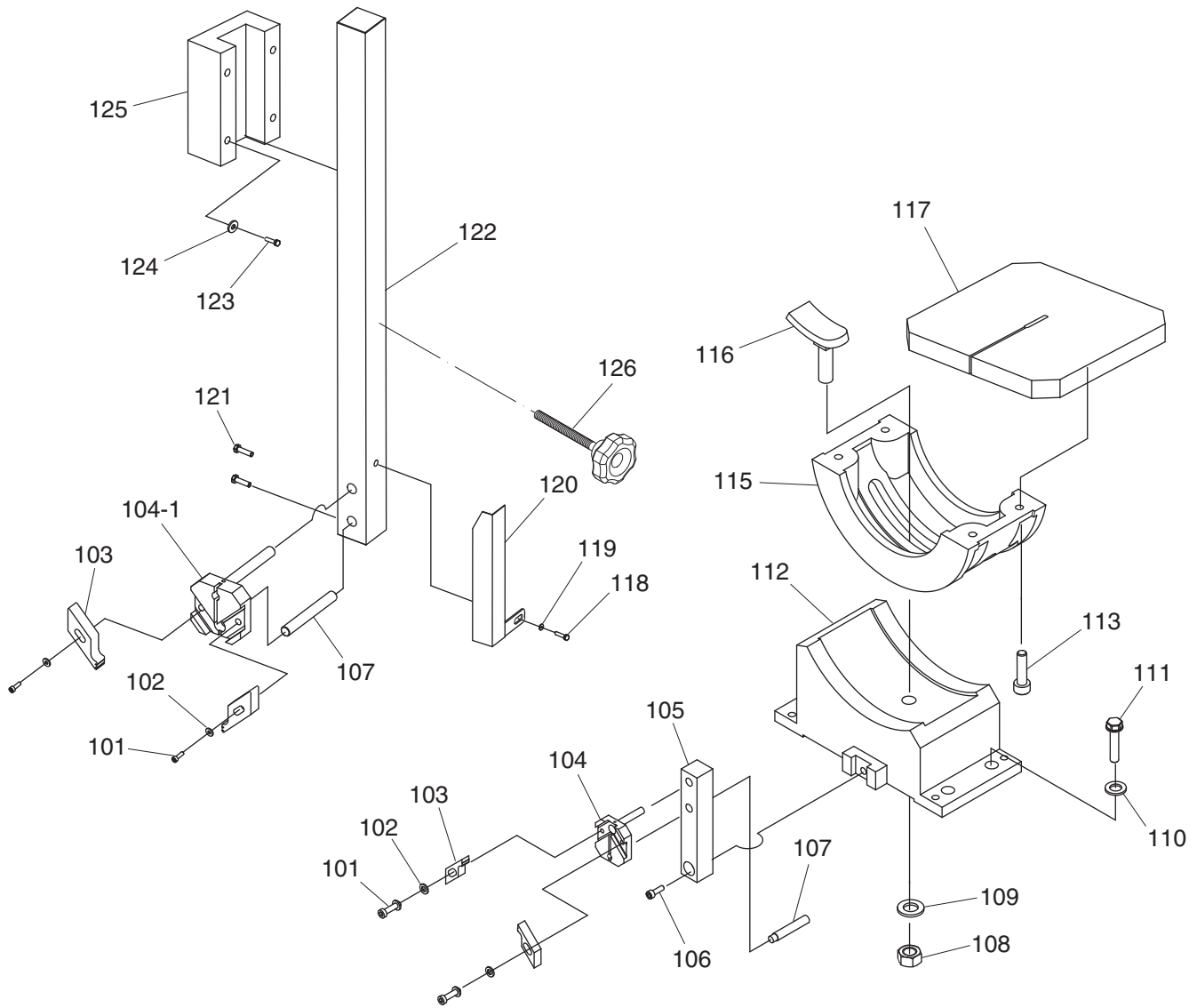

REF	PART #	DESCRIPTION
101	PSB15M	CAP SCREW M5-.8 X 20
102	PW02M	FLAT WASHER 5MM
103	P8144Z103	BLADE GUIDE
104	P8144Z104	BLADE GUIDE BRACKET LOWER
104-1	P8144Z104-1	BLADE GUIDE BRACKET UPPER
105	P8144Z105	GUIDE POST LOWER
106	PSB64M	CAP SCREW M10-1.5 X 25
107	P8145Z107	BLADE SUPPORT
108	PN04	HEX NUT 5/8-11
109	PLW06	LOCK WASHER 5/8
110	PW01M	FLAT WASHER 8MM
111	PB26M	HEX BOLT M8-1.25 X 30
112	P8144Z112	TRUNNION BASE

REF	PART #	DESCRIPTION
113	PSB31M	CAP SCREW M8-1.25 X 25
115	P8144Z115	TRUNNION
116	P8144Z116	TABLE TILT LOCK 5/8-11 X 2
117	P8145Z117	TABLE
118	PSB11M	CAP SCREW M8-1.25 X 16
119	PW01M	FLAT WASHER 8MM
120	P8145Z120	BLADE GUARD
121	PSB11M	CAP SCREW M8-1.25 X 16
122	P8145Z122	GUIDE POST UPPER
123	PSB13M	CAP SCREW M8-1.25 X 30
124	PW01M	FLAT WASHER 8MM
125	P8145Z125	GUIDE POST WAY
126	P8144Z126	KNOB M12-1.75 X 70 6-LOBES



G8145Z Drive System Breakdown

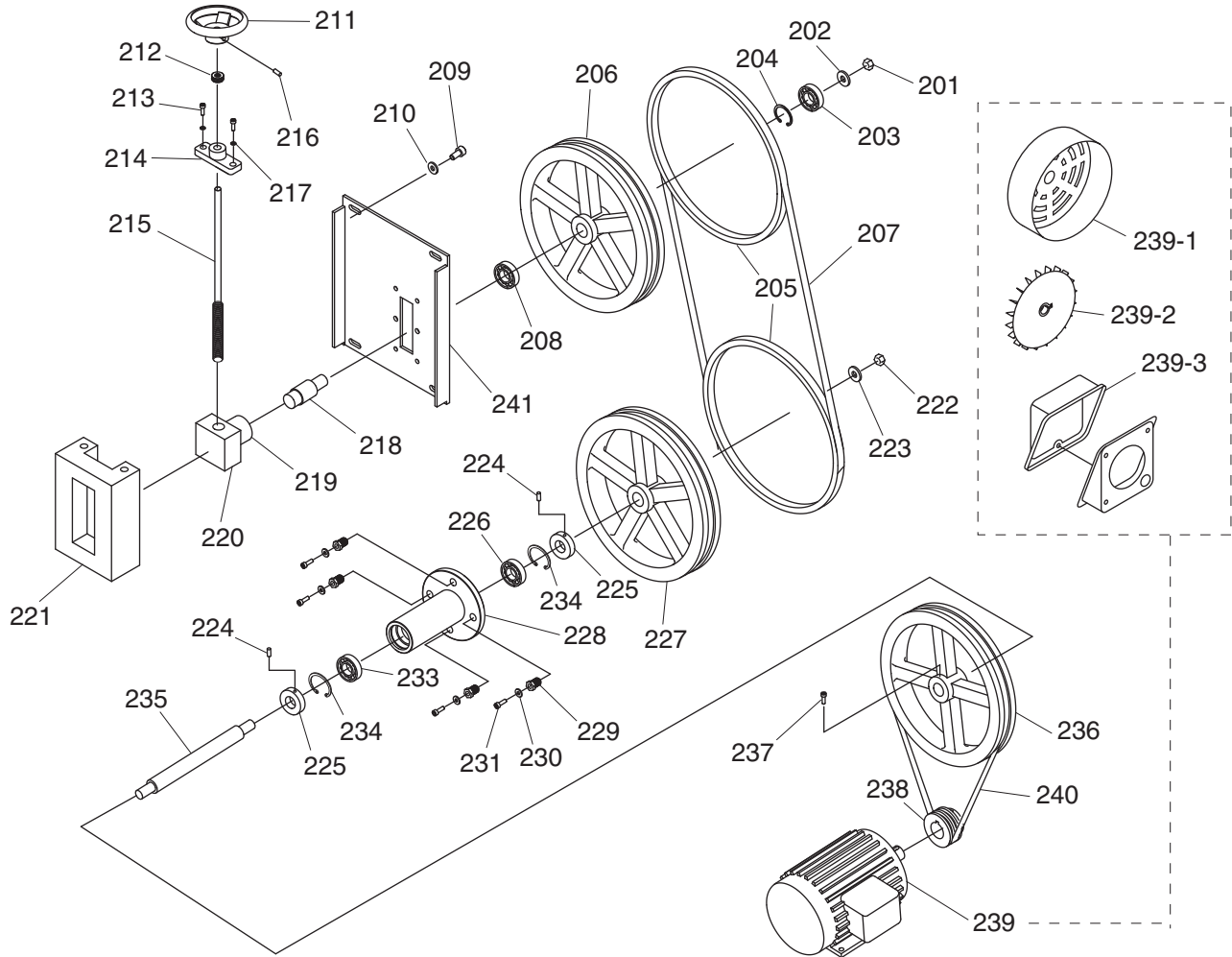

REF	PART #	DESCRIPTION
201	PN01	HEX NUT 1/2-20
202	PLW07	LOCK WASHER 1/2
203	P6203	BALL BEARING 6203ZZ
204	PR23M	INT RETAINING RING 40MM
205	P8145Z205	WHEEL TIRE
206	P8145Z206	WHEEL UPPER
207	P8145Z207	BANDSAW BLADE 1/4"W STANDARD
208	P6203	BALL BEARING 6203ZZ
209	PB02M	HEX BOLT M6-1 X 12
210	PW03M	FLAT WASHER 6MM
211	P8144Z211	BLADE TENSIONING HANDWHEEL
212	P8144Z212	BUSHING
213	PSB13M	CAP SCREW M8-1.25 X 30
214	P8144Z214	LEADSCREW BRACKET
215	P8144Z215	LEADSCREW 3/4-6 x 7
216	PSS09M	SET SCREW M8-1.25 X 20
217	PLW04M	LOCK WASHER 8MM
218	P8144Z218	UPPER WHEEL SHAFT
219	P8144Z219	BUSHING
220	P8144Z220	LEADSCREW NUT 3/4-6
221	P8144Z221	TENSIONING WAY
222	PN09	HEX NUT 5/8-18

REF	PART #	DESCRIPTION
223	PLW06	LOCK WASHER 5/8
224	PSS20M	SET SCREW M8-1.25 X 8
225	P8144Z225	COLLAR
226	P6203	BALL BEARING 6203ZZ
227	P8145Z227	WHEEL LOWER
228	P8144Z228	BEARING HOUSING
229	P8145Z229	SPECIAL SCREW 3/4-16
230	PLW06M	LOCK WASHER 10MM
231	PB73M	HEX BOLT M10-1.5 X 50
233	P6205	BALL BEARING 6205ZZ
234	PR26M	INT RETAINING RING 52MM
235	P8144Z235	LOWER WHEEL SHAFT
236	P8145Z236	WHEEL PULLEY
237	PSB36M	CAP SCREW M12-1.75 X 25
238	P8145Z238	MOTOR PULLEY
239	P8145Z239	MOTOR 1-1/2HP 220V 3PH
239-1	P8145Z239-1	MOTOR FAN COVER
239-2	P8145Z239-2	MOTOR FAN
239-3	P8145Z239-3	MOTOR WIRING JUNCTION BOX
240	PVA58	V-BELT A-58 4L580
241	P8145Z241	TENSIONING PANEL



Welder Station Breakdown

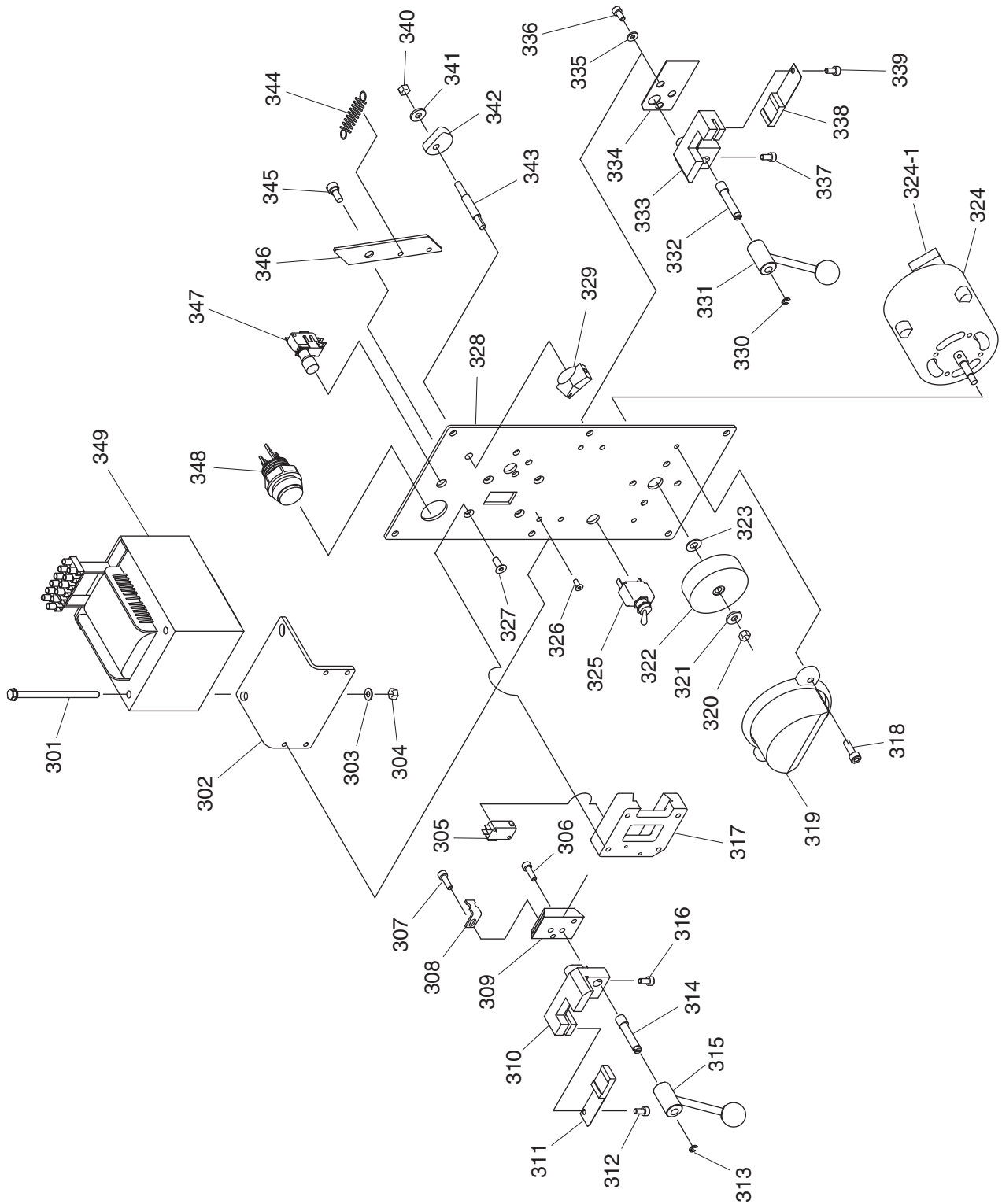

Welder Station Parts List

REF	PART #	DESCRIPTION
301	PB96	HEX BOLT 1/4-20 X 4
302	P8144Z302	TRANSFORMER BRACKET
303	PW06	FLAT WASHER 1/4
304	PN05	HEX NUT 1/4-20
305	P8144Z305	LIMIT SWITCH
306	PSB06M	CAP SCREW M6-1 X 25
307	PSB04M	CAP SCREW M6-1 X 10
308	P8144Z308	LIMIT SWITCH BRACKET
309	P8144Z309	SLIDING BLOCK
310	P8144Z310	WELDING CLAMP LEFT
311	P8144Z311	WELDING JAW LEFT
312	PSB26M	CAP SCREW M6-1 X 12
313	PEC02M	E-CLIP 4MM
314	P8144Z314	SHAFT
315	P8144Z315	CLAMP LEVER
316	PSB26M	CAP SCREW M6-1 X 12
317	P8144Z317	SLIDING BLOCK BASE
318	PS11M	PHLP HD SCR M6-1 X 16
319	P8144Z319	GRINDER COVER
320	PN01M	HEX NUT M6-1
321	PW03M	FLAT WASHER 6MM
322	P8144Z322	GRINDING WHEEL 2-1/2"D
323	PW03M	FLAT WASHER 6MM
324	P8144Z324	GRINDER MOTOR 1/8HP 220V 1PH
324-1	P8144Z324-1	S CAPACITOR 3M 250V 3/4 X 1-1/4
325	P8144Z325	ON/OFF SWITCH

REF	PART #	DESCRIPTION
326	PS11M	PHLP HD SCR M6-1 X 16
327	PS26M	PHLP HD SCR M6-1 X 20
328	P8144Z328	WELDING PANEL
329	P8144Z329	CLAMP PRESSURE KNOB
330	PEC02M	E-CLIP 4MM
331	P8144Z331	CLAMP LEVER
332	P8144Z332	SHAFT
333	P8144Z333	WELDING CLAMP RIGHT
334	P8144Z334	INSULATING PLATE
335	PW03M	FLAT WASHER 6MM
336	PSB02M	CAP SCREW M6-1 X 20
337	PSB02M	CAP SCREW M6-1 X 20
338	P8144Z338	WELDING JAW RIGHT
339	PSB02M	CAP SCREW M6-1 X 20
340	PN01M	HEX NUT M6-1
341	PW03M	FLAT WASHER 6MM
342	P8144Z342	PRESSURE CAM
343	P8144Z343	CAM SHAFT
344	P8144Z344	TENSION SPRING 0.8 X 25MM
345	PS04	PHLP HD SCR 1/4-20 X 1/2
346	P8144Z346	BRACKET
347	P8144Z347	ANNEALING PUSH BUTTON
348	P8144Z348	WELDING PUSH BUTTON
349	P8144Z349	TRANSFORMER 1.2KVA 220V (G8144Z)
349	P8145Z349	TRANSFORMER 2KVA 220V (G8145Z)
349	P8146Z349	TRANSFORMER 4.2KVA 220V (G8146Z)



Label Placement & List

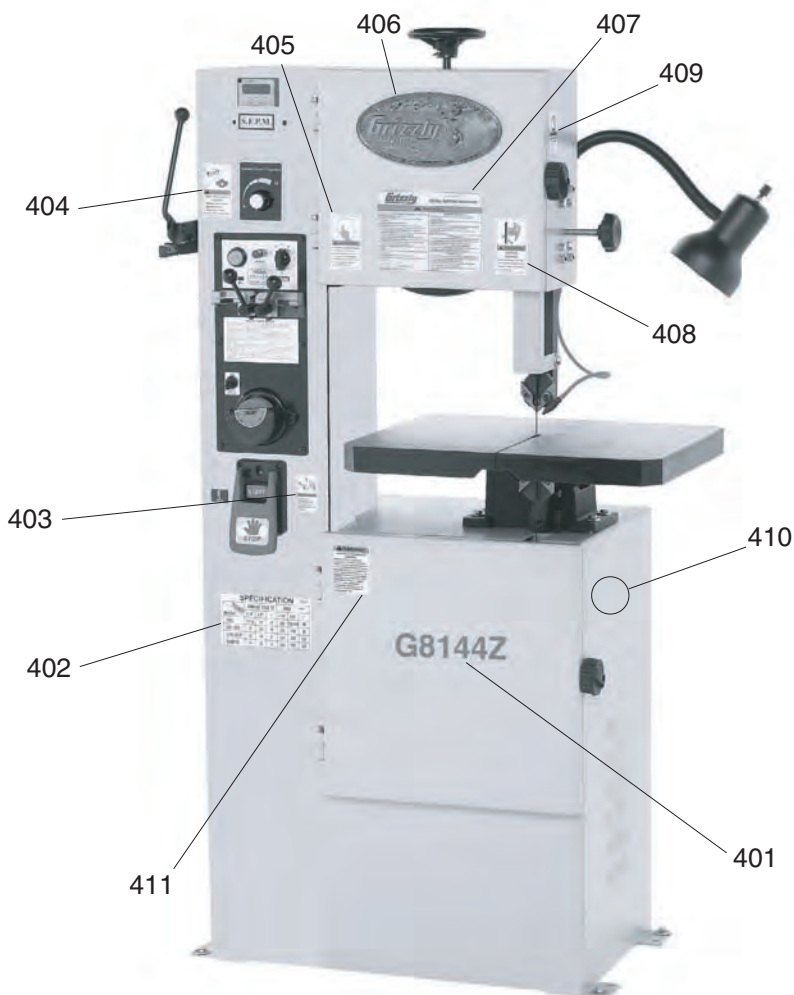

REF	PART #	DESCRIPTION
401	P8144Z401	MODEL # LABEL (G8144Z)
401	P8145Z401	MODEL # LABEL (G8145Z)
401	P8146Z401	MODEL # LABEL (G8146Z)
402	P8144Z402	BLADE SPECIFICATION LABEL
403	P8144Z403	POWER DISCONNECT LABEL VERT S
404	P8144Z404	EYE/LUNG HAZARD LABEL VERT L
405	P8144Z405	READ MANUAL LABEL VERT L
406	G8588	GRIZZLY NAMEPLATE 9-1/2" X 4-1/2"

REF	PART #	DESCRIPTION
407	P8144Z407	MACHINE ID LABEL (G8144Z)
407	P8145Z407	MACHINE ID LABEL (G8145Z)
407	P8146Z407	MACHINE ID LABEL (G8146Z)
408	P8144Z408	BLADE HAZARD LABEL VERT L
409	P8144Z409	DOOR INJURY HAZARD LABEL VERT S
410	PPAINT-11	GRIZZLY PUTTY TOUCH UP PAINT
411	P8144Z411	UNSTABLE WORKPIECE LABEL

WARNING

Safety labels warn about machine hazards and ways to prevent injury. The owner of this machine **MUST** maintain the original location and readability of the labels on the machine. If any label is removed or becomes unreadable, **REPLACE** that label before using the machine again. Contact Grizzly at (800) 523-4777 or www.grizzly.com to order new labels.

