

SECTION 7: PARTS

Parts Breakdown

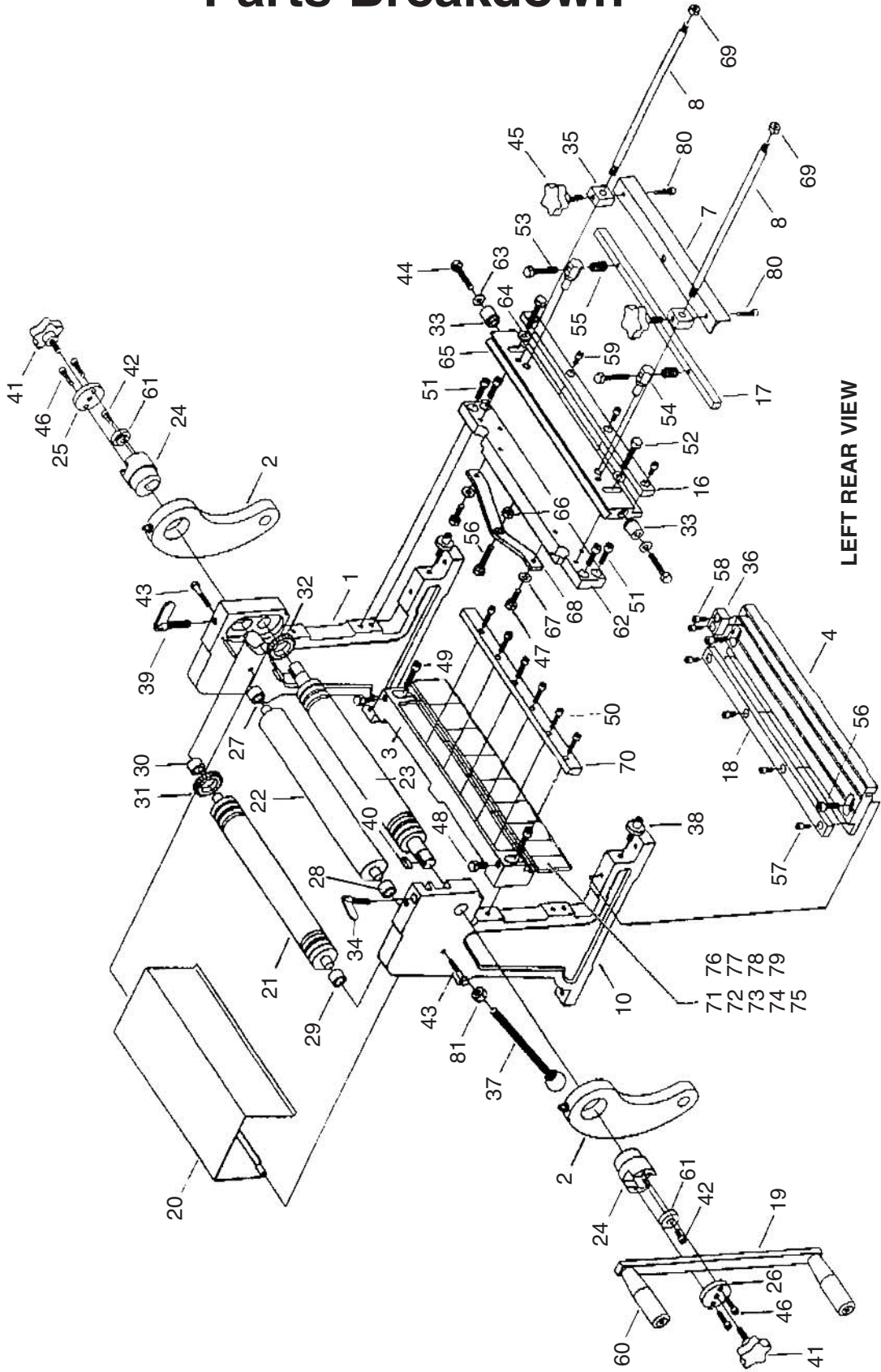

LEFT REAR VIEW



Parts List

REF	PART #	DESCRIPTION
1	P0629001	RIGHT FRAME CASTING
2	P0629002	CRANK ARM
3	P0629003	CARRIAGE CASTING
4	P0629004	TABLE
7	P0629007	STOP ANGLE
8	P0629008	STOP ROD
10	P0629010	LEFT FRAME CASTING
16	P0629016	UPPER BLADE
17	P0629017	CLAMP BAR
18	P0629018	LOWER BLADE
19	P0629019	WORK LEVER
20	P0629020	COVER
21	P0629021	TOP ROLLER
22	P0629022	REAR ROLLER
23	P0629023	BOTTOM ROLLER
24	P0629024	HUB
25	P0629025	RIGHT HUB PLATE
26	P0629026	LEFT HUB PLATE
27	P0629027	BUSHING
28	P0629028	BUSHING
29	P0629029	BUSHING
30	P0629030	BUSHING
31	P0629031	GEAR T-25
32	P0629032	GEAR T-25
33	P0629033	BUSHING
34	P0629034	LEAF LOCK PIN
35	P0629035	STOP BLOCK
36	P0629036	GUIDE BLOCK
37	P0629037	ADJUSTMENT ROD W/KNOB
38	P0629038	SPECIAL ADJUSTMENT SCREW
39	P0629039	LEAF BOLT
40	PK91M	KEY 8 X 8 X 22
41	P0629041	KNOB
42	PSB01M	CAP SCREW M6-1 X 16
43	PB28M	HEX BOLT M8-1.25 X 60
44	PB140M	HEX BOLT M12-1.75 X 70
45	P0629045	KNOB

REF	PART #	DESCRIPTION
46	PSB01M	CAP SCREW M6-1 X 16
47	PB132M	HEX BOLT M16-2 X 40
48	PB49M	HEX BOLT M12-1.75 X 20
49	P0629049	CAP SCREW M16-2 X 55
50	PSB31M	CAP SCREW M8-1.25 X 25
51	P0629051	CAP SCREW M16-2 X 35
52	PB24M	HEX BOLT M12-1.75 X 45
53	PB121M	HEX BOLT M12-1.75 X 100
54	P0629054	ANCHOR STUD
55	P0629055	COMPRESSION SPRING
56	P0629056	HEX BOLT M16-2 X 35
57	PSB100M	CAP SCREW M8-1.25 X 15
58	PSB28M	CAP SCREW M6-1 X 15
59	PSB100M	CAP SCREW M8-1.25 X 15
60	P0629060	HANDLE
61	P0629061	FLANGE PLATE
62	P0629062	ANVIL CASTING
63	PW06M	FLAT WASHER 12MM
64	PW06M	FLAT WASHER 12MM
65	P0629065	FINGER RECEIVER
66	PN13M	HEX NUT M16-2
67	PLW10M	LOCK WASHER 16MM
68	P0629068	STEEL STRAP
69	PN13M	HEX NUT M16-2
70	P0629070	GIB
71	P0629071	FINGER 14-3/4"
72	P0629072	FINGER 10"
73	P0629073	FINGER 9"
74	P0629074	FINGER 7"
75	P0629075	FINGER 4"
76	P0629076	FINGER 2-1/2"
77	P0629077	FINGER 2"
78	P0629078	FINGER 1-1/2"
79	P0629079	FINGER 1"
80	PB49M	HEX BOLT M12-1.75 X 20
81	PN13M	HEX NUT M16-2



Label Placement

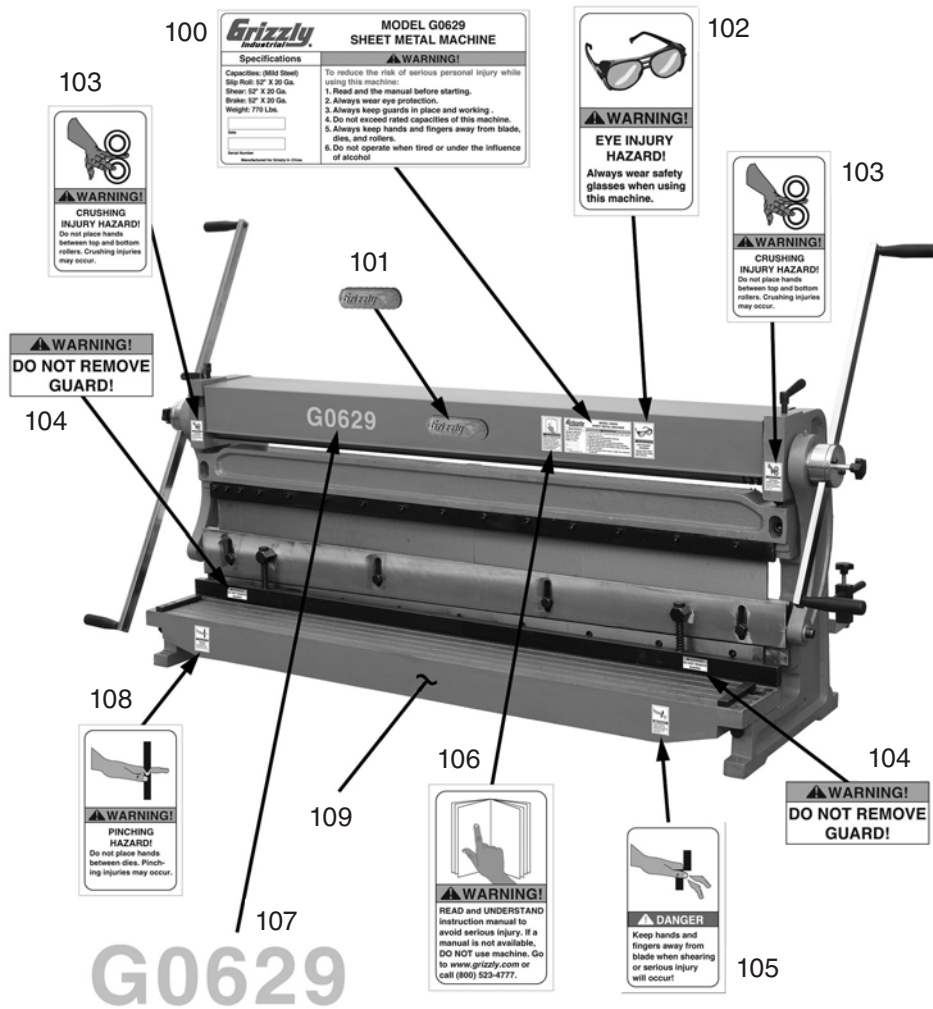

REF	PART #	DESCRIPTION
100	P0629100	MACHINE DATA LABEL
101	H4609	DOMED LOGO LABEL
102	PLABEL-11A	SAFETY GLASSES LABEL
103	P0629103	SLIP ROLL WARNING LABEL
104	P0629104	GUARD LABEL

REF	PART #	DESCRIPTION
105	P0629105	SHEAR WARNING LABEL
106	PLABEL-12A	READ MANUAL LABEL
107	P0629107	MODEL NUMBER LABEL
108	P0629108	BRAKE WARNING LABEL
109	PPAINT-1	GRIZZLY GREEN SPOT PAINT

WARNING

Safety labels warn about machine hazards and ways to prevent injury. The owner of this machine **MUST** maintain the original location and readability of the labels on the machine. If any label is removed or becomes unreadable, **REPLACE** that label before using the machine again. Contact Grizzly at (800) 523-4777 or www.grizzly.com to order new labels.

