

Grizzly *Industrial, Inc.*®

BENCHTOP BENDER MODELS H5502 INSTRUCTION MANUAL

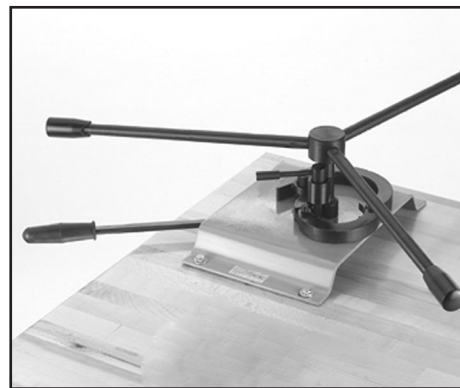
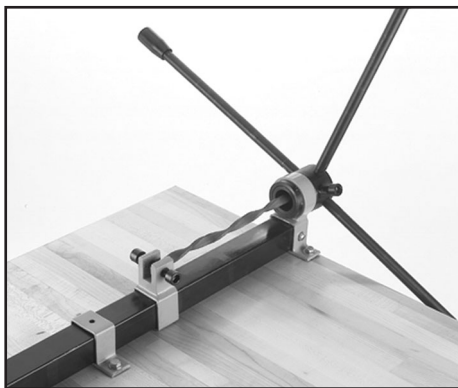
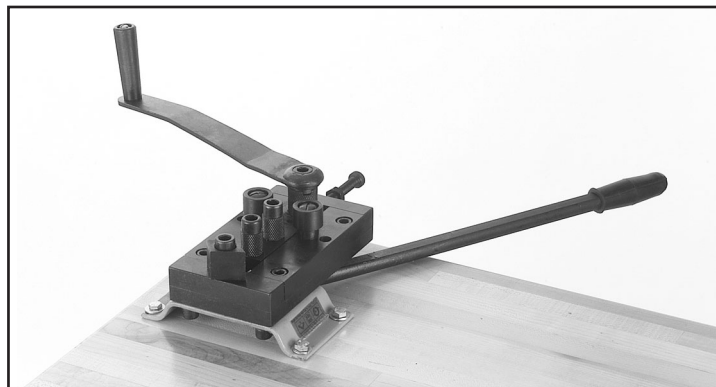

COPYRIGHT © JANUARY 2004 BY GRIZZLY INDUSTRIAL, INC.
**WARNING: NO PORTION OF THIS MANUAL MAY BE REPRODUCED IN ANY SHAPE
OR FORM WITHOUT THE WRITTEN APPROVAL OF GRIZZLY INDUSTRIAL, INC.**
#5872 PRINTED IN CHINA

SECTION 1: SAFETY

WARNING

For Your Own Safety Read Instruction Manual Before Operating This Equipment

The purpose of safety symbols is to attract your attention to possible hazardous conditions. This manual uses a series of symbols and signal words which are intended to convey the level of importance of the safety messages. The progression of symbols is described below. Remember that safety messages by themselves do not eliminate danger and are not a substitute for proper accident prevention measures.

 **DANGER** Indicates an imminently hazardous situation which, if not avoided, **WILL** result in death or serious injury.

 **WARNING** Indicates a potentially hazardous situation which, if not avoided, **COULD** result in death or serious injury.

 **CAUTION** Indicates a potentially hazardous situation which, if not avoided, **MAY** result in minor or moderate injury.

NOTICE This symbol is used to alert the user to useful information about proper operation of the equipment or property damage hazards.

WARNING

Safety Instructions For Metalworking Tools

1. **READ AND UNDERSTAND EQUIPMENT OWNERS MANUAL.**
2. **REMOVE ADJUSTING KEYS AND WRENCHES.** Form a habit of checking to see that keys and adjusting wrenches are removed from equipment.
3. **KEEP WORK AREA CLEAN.** Cluttered areas and benches invite accidents.
4. **DO NOT USE IN DANGEROUS ENVIRONMENT.** DO NOT use equipment in damp or wet locations. Keep work area well lighted and free of obstructions.
5. **KEEP CHILDREN AND VISITORS AWAY.** All children and visitors should be kept at a safe distance from work area.
6. **MAKE WORK SHOP CHILD PROOF** with padlocks, and lockout devices.
7. **DO NOT FORCE TOOL.** It will do the job better and safer at the rate for which it was designed.
8. **USE RIGHT TOOL.** DO NOT force tool or attachment to do a job for which it was not designed.

WARNING

Safety Instructions For Metalworking Tools

9. **USE PROPER EXTENSION CORD.** Make sure your extension cord is in good condition. Conductor size should be in accordance with the chart below. The amperage rating should be listed on the motor or tool nameplate. An undersized cord will cause a drop in line voltage resulting in loss of power and overheating. Your extension cord must also contain a ground wire and plug pin. Always repair or replace extension cords if they become damaged.

Minimum Gauge for Extension Cords

AMP RATING	LENGTH		
	25ft	50ft	100ft
0-6	16	16	16
7-10	16	16	14
11-12	16	16	14
13-16	14	12	12
17-20	12	12	10
21-30	10	10	No

10. **WEAR PROPER APPAREL.** DO NOT wear loose clothing, gloves, neckties, rings, bracelets, or other jewelry which may get caught in moving parts. Non-slip footwear is recommended. Wear protective hair covering to contain long hair.
11. **ALWAYS USE SAFETY GLASSES.** Everyday eyeglasses only have impact resistant lenses, they are NOT safety glasses.
12. **SECURE WORK.** Use clamps or vises to hold work while working on workpiece.
13. **DO NOT OVER-REACH.** Keep proper footing and balance at all times.

14. **MAINTAIN TOOLS AND EQUIPMENT WITH CARE.** Keep tools sharp and clean for best and safest performance. Follow instructions for lubricating and changing accessories.

15. **USE RECOMMENDED ACCESSORIES.** Consult the owner's manual for recommended accessories. The use of improper accessories may cause risk of injury.

16. **CHECK DAMAGED PARTS.** Before further use of the equipment, a guard or other part that is damaged should be carefully checked to determine that it will operate properly and perform its intended function. Check for alignment of moving parts, binding of moving parts, breakage of parts, mounting, and any other conditions that may affect its operation. A guard or other part that is damaged should be properly repaired or replaced.

17. **NEVER OPERATE EQUIPMENT WHEN TIRED, OR UNDER THE INFLUENCE OF DRUGS OR ALCOHOL.** Full mental alertness is required at all times when using equipment.

CAUTION

No list of safety guidelines can be complete. Every shop environment is different. Always consider safety first, as it applies to your individual working conditions. Use this and other equipment with caution and respect. Failure to do so could result in serious personal injury, damage to equipment or poor work results.

SECTION 2: INTRODUCTION

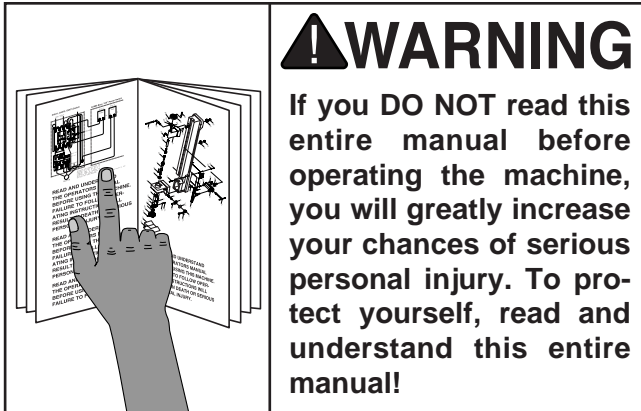

Commentary

Grizzly Industrial, Inc. is proud to offer the Model H5502 Benchtop Bending System. This bender is part of Grizzly's growing family of fine metalworking equipment. When used according to the guidelines stated in this manual, you can expect years of trouble-free, enjoyable operation, and proof of Grizzly's commitment to customer satisfaction.

We are also pleased to provide this manual for the Model H5502 Benchtop Bending System. It was written to guide you through assembly, review safety considerations, and cover general operating procedures. It represents our latest effort to produce the best documentation possible.

If you have any comments or criticisms that you feel we should address in our next printing, please write to us at:

Grizzly Industrial, Inc.
% Technical Documentation
P.O. Box 2069
Bellingham, WA 98227

Most important, we stand behind our machines. We have excellent regional service departments at your disposal should the need arise.

If you have any service questions or parts requests, please call or write to us at the location listed below.

Grizzly Industrial, Inc
1203 Lycoming Mall Circle
Muncy, PA 17756
Phone:(570) 546-9663
Fax:(800) 438-5901
E-Mail: techsupport@grizzly.com
Web Site: <http://www.grizzly.com>

The specifications, drawings, and photographs illustrated in this manual represent the Model H5502 as supplied when the manual was prepared. However, owing to Grizzly's policy of continuous improvement, changes may be made at any time with no obligation on the part of Grizzly. For your convenience, we always keep current Grizzly manuals available on our website at www.grizzly.com. Any updates to your machine will be reflected in these manuals as soon as they are complete.



SECTION 3: IDENTIFICATION

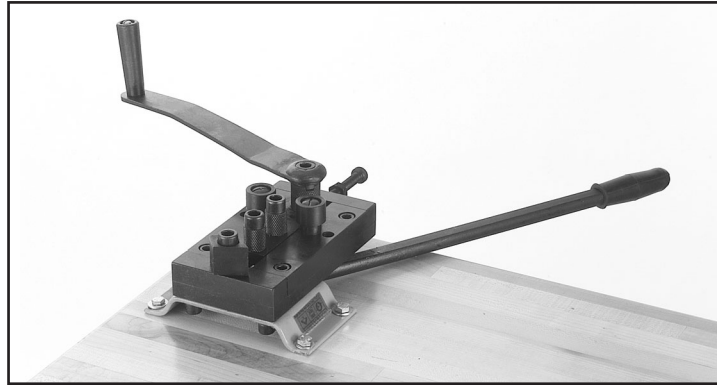

Bending Tool

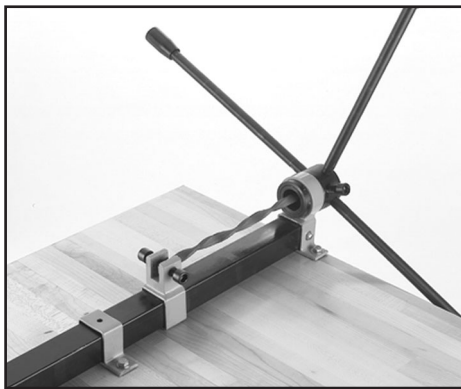

Twist Tool

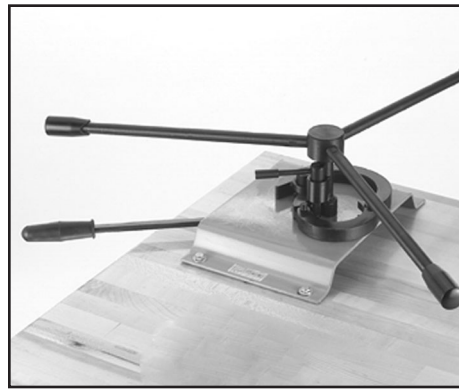

Scroll Tool



SECTION 4: SET UP

About this Section

The purpose of this section is to guide you through the required steps to get your machine out of its packaging and into operating condition.

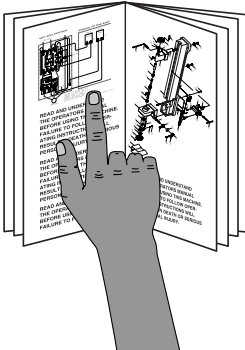

⚠️ WARNING
This equipment presents serious injury hazards to untrained users. Read through this entire manual to become familiar with the operating procedures before using this equipment!



⚠️ WARNING
Wear safety glasses during the entire setup process!



Inspection

The Model H5502 Benchtop Bending System was carefully packed before it left our warehouse. If you discover the equipment is damaged after you have signed for delivery, *please immediately call Customer Service at (570) 546-9663 for advice.*

Save the containers and all packing materials for possible inspection by the carrier or its agent. *Otherwise, filing a freight claim can be difficult.*

When you are completely satisfied with the condition of your shipment, you should inventory its parts.



Unpacking and Clean-Up

Remove the box from around the Model H5502 Benchtop Bending System (**Figure 1**). There will be a total of three tools and a bag of handles.

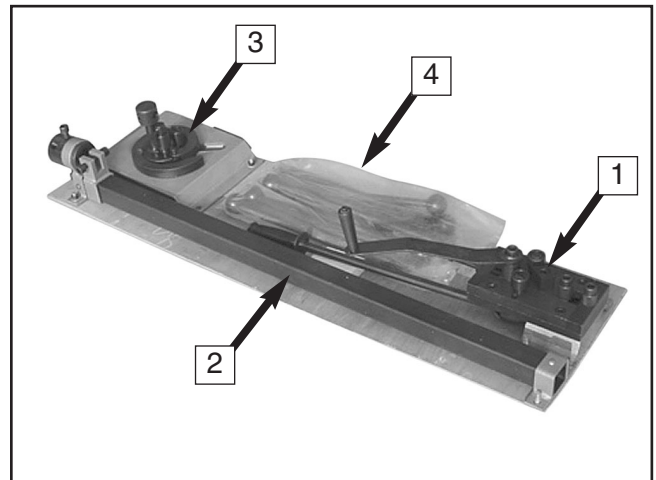

Figure 1. The three main tools with the handle and hardware bag.

- | | | |
|----|------------------------------|---|
| 1. | Bending Tool Assembly | 1 |
| 2. | Twist Tool Assembly | 1 |
| 3. | Scroll Tool Assembly | 1 |
| 4. | Handle and Hardware Bag | |
| | —Twist Tool Handles | 4 |
| | —Scroll Tool Handles | 4 |
| | —Hex Wrenches 8mm, 10mm..... | 2 |



Assembly

CAUTION

No list of safety guidelines can be complete. Every shop environment is different. Always consider safety first, as it applies to your individual working conditions. Use this and other machinery with caution and respect. Failure to do so could result in serious personal injury, damage to equipment or poor work results.

The assembly process is a very simple one. We have tried to make it as easy as possible so that you can start making your projects right away.

Twist Tool:

Thread the four handles into the hub.

Scroll Tool:

1. Attach the square handle to the bottom of the scroll tool base.
2. Thread the four handles into the hub.



Mounting

CAUTION

Make sure that the tool is mounted solid and secure to the work surface. Be aware of the surroundings when mounting tool, so that work may be done in all four sides.

When mounting the three tools to a solid, flat and level work surface, take note that all three of the tools have a different bolt hole pattern for mounting. Take some time to plan the layout.

1. Before mounting the Model H5502 to a flat and level work surface, make sure the mounting surface is solid enough to hold the tool and the work material.
2. Place the tool onto the work surface and make sure adequate work room has been given on all sides.
3. Using a pen or pencil, transfer the hole location to the mounting surface.
4. Mount the tool to the work surface using $\frac{5}{16}$ " bolts.



SECTION 5: OPERATIONS

Workpieces

Below are some of the workpieces that can be fabricated with the H5502 Bench Top Bending System (**Figure 2**).

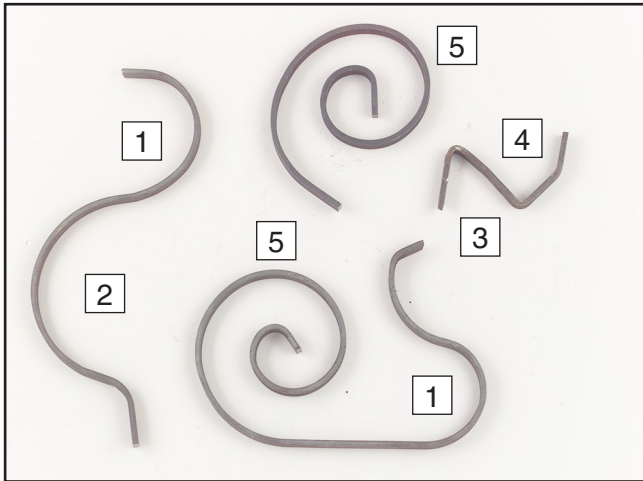

Figure 2. Main view of the three tools.

1. Small Roll
2. Large Roll
3. 45° Angle Bend
4. 60° Angle Bend
5. Scroll



Technical Data

Twist Tool:

Rectangular Stock:

1 1/4" X 1/4" X 40" (**MILD STEEL**)

Square Stock:

3/8" X 40" (**MILD STEEL**)

Round Stock:

3/8" X 40" (**MILD STEEL**)

Scroll Tool:

Rectangular Stock:

1 1/4" X 1/4" (**MILD STEEL**)

Square Stock:

3/8" X 3/8" (**MILD STEEL**)

Round Stock:

3/8" Ø (**MILD STEEL**)

Bender:

Angle Range:

60°-90° (**MILD STEEL**)

Min. Circle Diameter:

2 3/8" (**MILD STEEL**)

Riveting Capacity:

1/8" X 1 1/4" (**MILD STEEL**)

3/16" X 1 1/4" (**MILD STEEL**)

1/4" X 1 1/4" (**MILD STEEL**)



Tool Functions

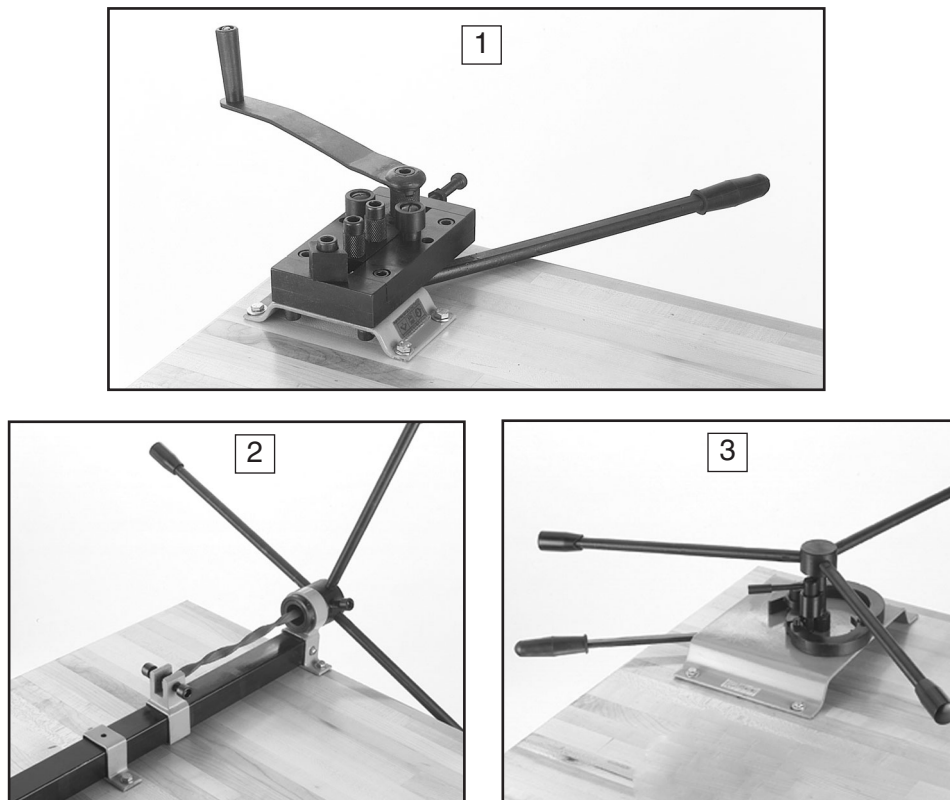

Figure 3. Bending tools.

Functions

1. **Bending tool**—Used for three different types of operations.

A—Bending metal at precise angles ranging from 0-60° and 0-90° depending on which side of the bending block is needed to complete the task at hand.

B—Rolling metal, making curves of various degrees, diameters and shapes. There are two positions for the guide rollers to locate into. The inner holes are for smaller diameters and shapes and the outer holes are for larger ones.

C—Riveting is another function that can be done to join two pieces of metal together using rivets.

2. **Twist tool**—Used to make decorative types of metal simply by holding one end of the metal and turning or rotating the other end until the desired effect is achieved.
3. **Scroll tool**—Used to make ornamental and useful type scrolls. The scroll tool comes with two dies to expand the capacity of the scroll effect.



Bender

Bending, rolling, and riveting are the basic functions of this tool.

CAUTION

Make sure that the tool is mounted solid and secure to the work surface. Be aware of the surroundings when mounting tool, so that work may be done in all four sides.



WARNING

Wear safety glasses during the entire fabrication process!

Using the bending block:

1. The bending block has two main positions. In one position the block can bend the metal at a minimum angle of 60° (**Figure 4**) and the other at a minimum angle of 90° (**Figure 5**). Choose the one best for the task at hand.

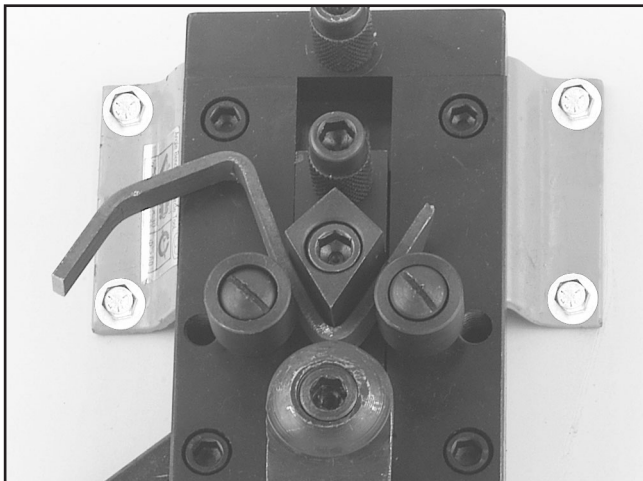

Figure 4. Workpiece bent with the 60° side of the bending block.

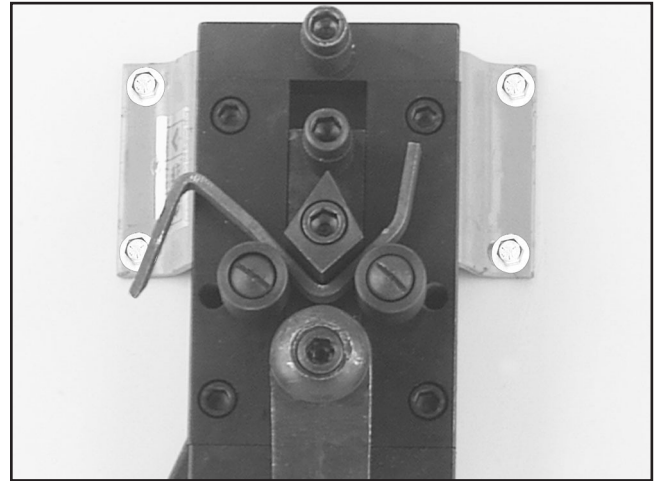

Figure 5. Workpiece bent with the 90° side of the bending block.

2. Place the workpiece between the bending block and the guide rollers (**Figure 6**).

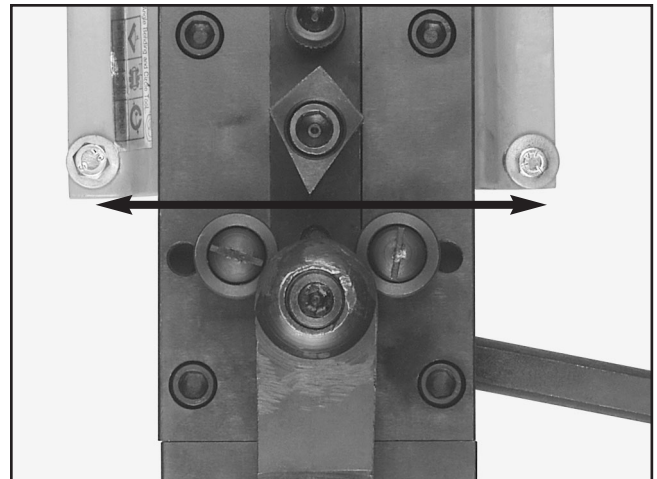

Figure 6. Work placement for the bending block.

3. With the desired angle of the bending block facing the guide rollers, move the square handle until the desired angle is reached. For more angle, move the square handle farther and for less angle do not move it as far.
4. Once the desired angle is reached, back off of the bending block by moving the square handle the opposite direction. When there is enough clearance remove the workpiece.

CAUTION

Make sure that the tool is mounted solid and secure to the work surface. Be aware of the surroundings when mounting tool, so that work may be done in all four sides.



WARNING

Wear safety glasses during the entire fabrication process!

Using the roll:

The roll can be used for many different shapes and sizes of arcs, radii, or custom designs. The first thing to do is get a workpiece.

1. Move the slide block with the feed roller and crank attached as far away from the guide rollers as you can by moving the square handle. If the adjustment screw is stopping the slide block from opening all the way, just back off the adjustment screw until the slide block opens all the way.
2. Place the workpiece between the feed roller and the guide rollers (**Figure 7**).

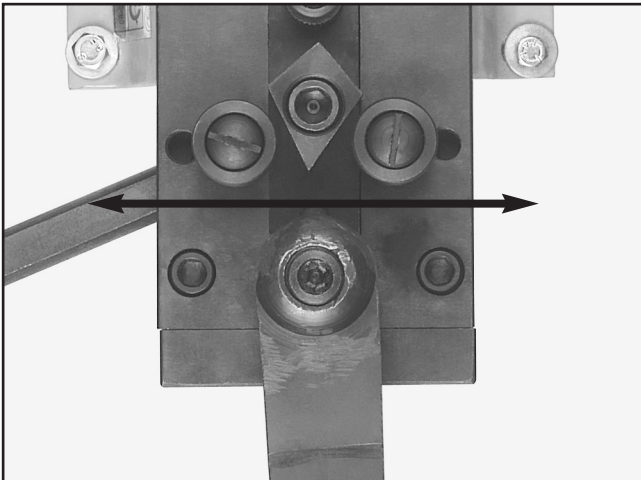

Figure 7. Work placement for rolling.

3. Using the square handle, squeeze the workpiece between the feed roller and the guide rollers.
4. Rotate the crank to start to form the workpiece. The more you move the square handle, the smaller the radius will become.
5. Keep rotating the crank until the desired radius is achieved (**Figure 8 and 9**).

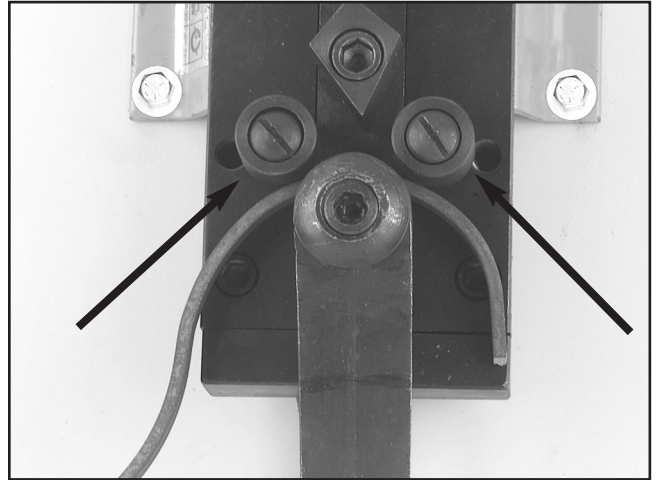

Figure 8. Guide rollers positioned in the inner location for smaller radii.

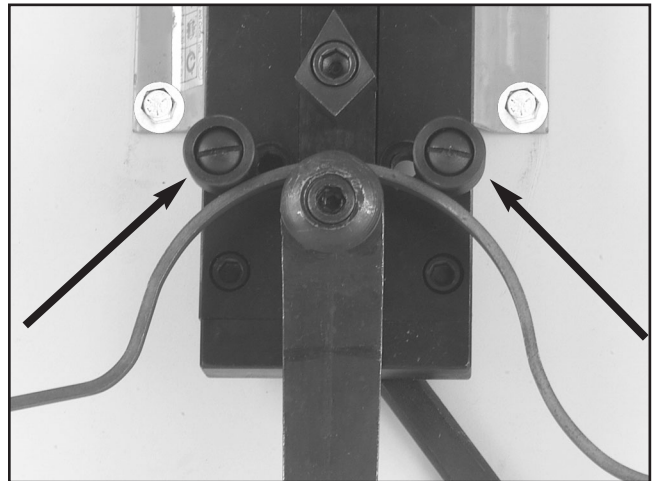

Figure 9. Guide rollers positioned in the outer location for larger radii.

6. When the desired look is achieved, move the square handle the opposite direction to remove the workpiece.

CAUTION

Make sure that the tool is mounted solid and secure to the work surface. Be aware of the surroundings when mounting tool, so that work may be done in all four sides.



WARNING

Wear safety glasses during the entire fabrication process!

Using the riveter:

1. Mark the hole location.
2. Punch or drill the holes to the proper diameter to accommodate the rivet being used.
3. Move the square handle to open the area between the press rollers.
4. Place the two pieces of metal to be riveted together (with the punched or drilled holes aligned) into the space between the press rollers (**Figure 10**).

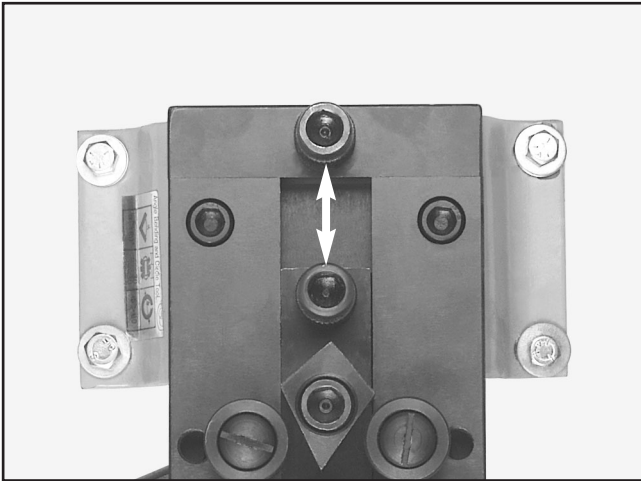

Figure 10. Metal placement.

5. With the holes aligned, place the rivet in the hole and center the rivet between the press rollers.
6. Move the square handle to squeeze the rivet between the press rollers. The rivet must be squeezed to expand enough to lock the two pieces of metal together.
7. When the rivet is set, release the pressure on the rivet and spread the press rollers apart to retrieve the riveted workpieces.



Twist Tool

⚠ CAUTION

Make sure that the tool is mounted solid and secure to the work surface. Be aware of the surroundings when mounting tool, so that work may be done in all four sides.



⚠ WARNING

Wear safety glasses during the entire fabrication process!

The twist tool allows the user to produce twists or spirals by rotating the workpiece.

Using the Twist Tool:

1. Insert the workpiece through the hub of the twist tool until the desired portion of the workpiece is shown, and tighten the cap screws down on the hub to hold the workpiece (Figure 11).

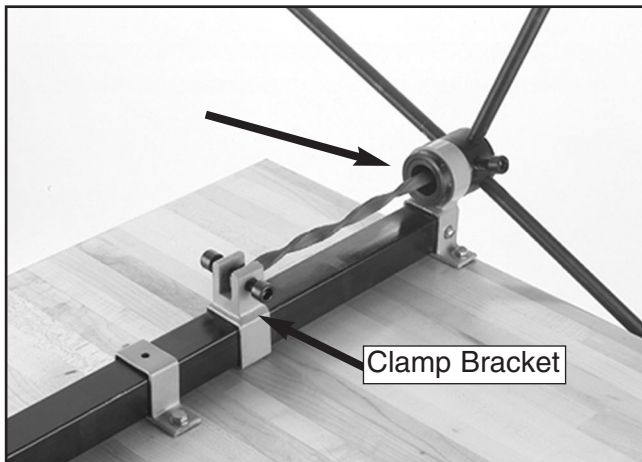

Figure 11. Workpiece inserted through the hub.

2. Slide the clamp bracket down the body of the twist tool until it is in the proper location to clamp the workpiece.

3. With the cap screws located in the clamp bracket, lock the workpiece down tightly to ensure the cap screws will hold the workpiece while twisting (Figure 12).

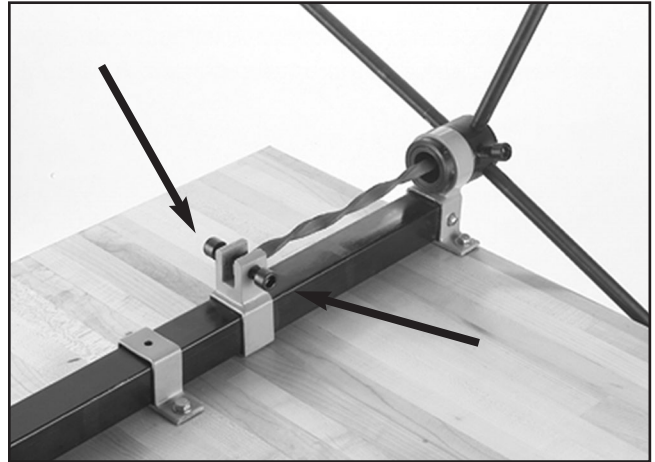

Figure 12. Securing the workpiece.

4. Retighten the cap screws in the hub to ensure that the workpiece is locked in place.
5. Now rotate the hub using the handle bars until the desired effect is achieved.
6. Once the workpiece has the desired look, loosen the cap screws on the hub and the clamp bracket to remove the workpiece.

⚠ CAUTION

No list of safety guidelines can be complete. Every shop environment is different. Always consider safety first, as it applies to your individual working conditions. Use this and other equipment with caution and respect. Failure to do so could result in serious personal injury, damage to equipment or poor work results.



Scroll Tool

The scroll tool is designed to wrap the workpiece around the dies to make a spiral or a “scroll” shape.

⚠ CAUTION

Make sure that the tool is mounted solid and secure to the work surface. Be aware of the surroundings when mounting tool, work may be done in all four sides.



⚠ **WARNING**
Wear safety glasses during the entire fabrication process!

Using the scroll tool:

1. Choose the desired workpiece to scroll.
2. Slide the workpiece between the offset shaft and the hub die assembly (**Figure 13**).

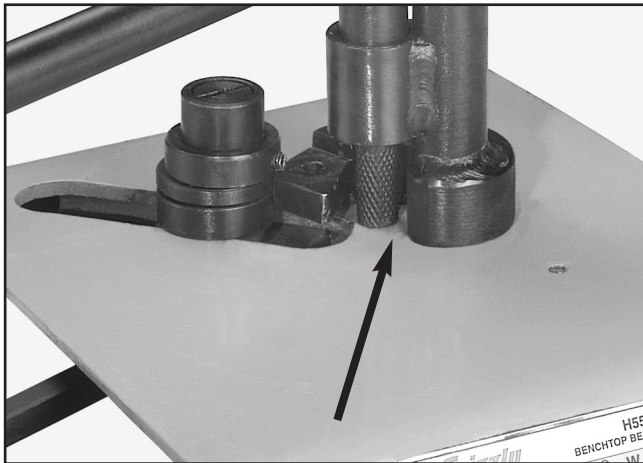

Figure 13. Workpiece placement for scroll.

3. Once in place, rotate the clamp handle to lock the workpiece.
4. Rotate the hub die assembly clockwise to start the scroll.
5. Use the square handle bar to move the guide sleeve. Note—*You can manipulate the size of the scroll while rotating the hub die assembly if so desired. For larger scrolls, add the small and large dies in this order as needed to reach the desired size scroll.*
6. Once the workpiece has the desired look, loosen the clamp handle and remove the workpiece.

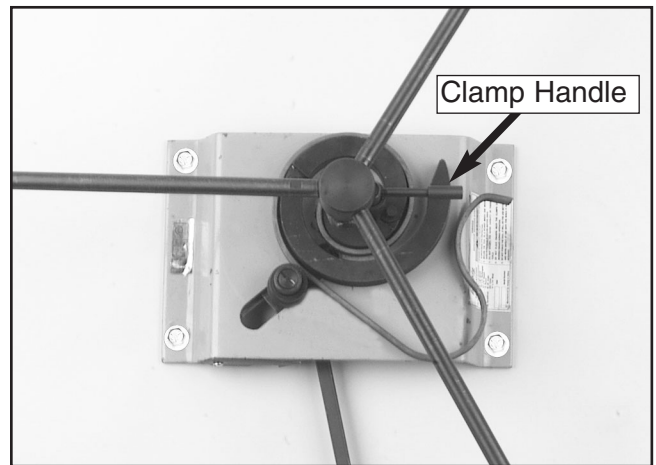

Figure 14. A finished scroll wrapped around the dies.



Adjustment Screw

If many of the same parts and pieces are going to be fabricated, the adjustment screw will help make these parts quickly. The adjustment screw is a feature that does not need to be used, but if used, is a real time saver and will improve repeatability and accuracy when used correctly.

Using the adjustment screw with the bending block:

The adjustment screw is basically a stop or a reference point that can be locked in place to ensure repeatability.

1. After bending the workpiece to the desired angle, run the adjusting screw until it is tight against the slide block (**Figure 15**).

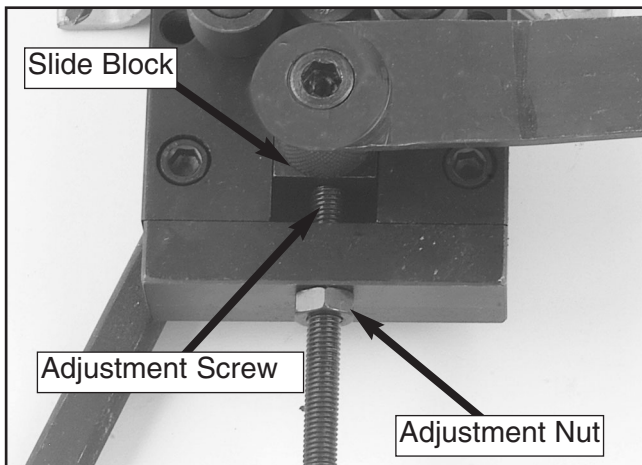

Figure 15. Adjustment screw against the slide block.

2. Run the adjustment nut up against the back block, locking the adjustment screw. Note—*Each time a workpiece is bent the slide block travel is limited by the adjustment screw.*

Using the adjustment screw with the roll:

1. When the workpiece is at the desired shape, do not release pressure on the square handle until the adjustment screw is snug against the slide block (**Figure 15**).
2. Tighten the adjustment nut until it is in contact with the rear block (**Figure 16**).

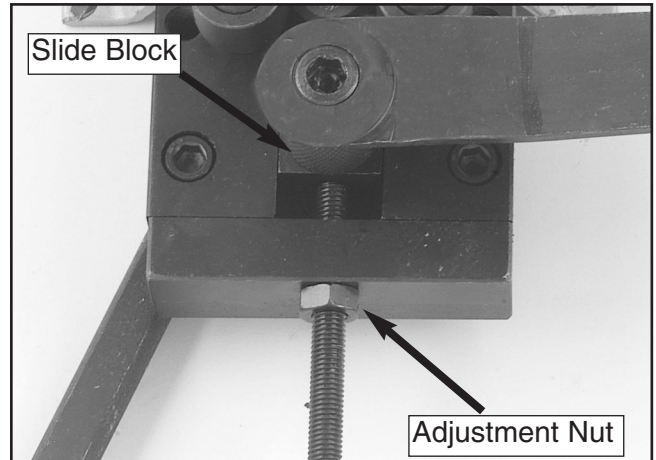

Figure 16. Adjustment nut against the back block.

3. Move the square handle to take pressure off of the adjustment screw, back the adjustment screw out, allowing the feed roller to move away from the guide rollers.
4. Insert another workpiece to be rolled.
5. Tighten the adjustment screw until the adjustment nut contacts the back block to reference the workpiece.



SECTION 6 : REFERENCE INFO

The following pages contain general machine data, parts diagrams, parts lists and Warranty/Return information for your Model H5502.

If you need parts or help in assembling your machine, or if you need operational information, call the Grizzly Service Department. Trained service technicians will be glad to help you.

If you have any comments regarding this manual, please write to Grizzly at the address below:

Grizzly Industrial, Inc.
c/o Technical Documentation
P.O. Box 2069
Bellingham, WA 98227-2069

We recommend you keep a copy of our current catalog for complete information regarding Grizzly's warranty and return policy. If you need additional technical information relating to this machine, or if you need general assistance or replacement parts, please contact the Service Department at the location listed below.

Grizzly Industrial, Inc.
1203 Lycoming Mall Circle
Muncy, PA 17756
Phone: (570) 546-9663
Fax: (800) 438-5901
E-Mail: techsupport@grizzly.com
Web Site: <http://www.grizzly.com>.



Model H5502 Parts Breakdown Twist Tool

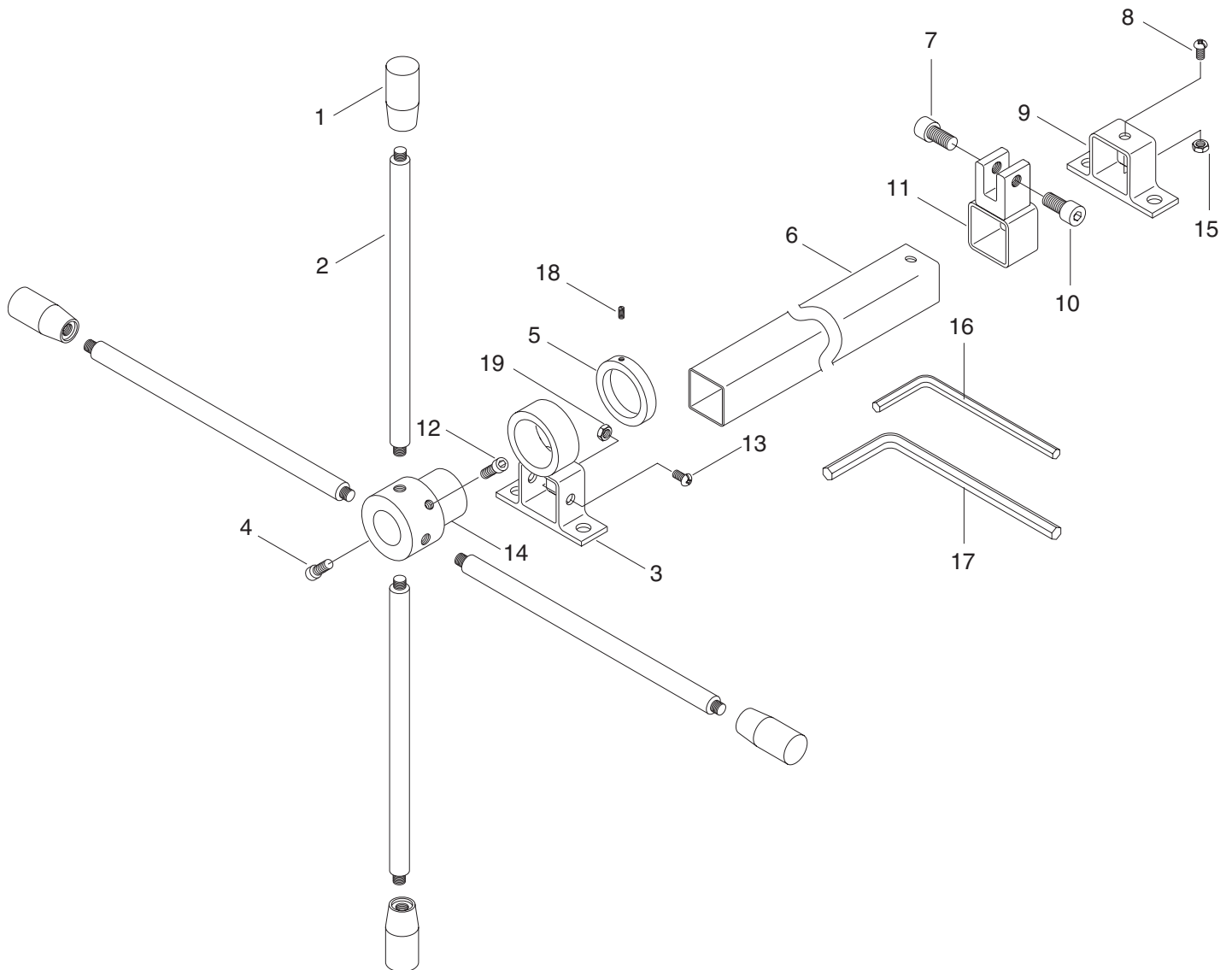

REF	PART #	DESCRIPTION
1	PH5502001	HANDLE GRIP
2	PH5502002	HANDLE BAR
3	PH5502003	MOUNTING BRACKET
4	PSB92M	CAP SCREW M12-1.75 X 40
5	PH5502005	SET COLLAR
6	PH5502006	BODY

REF	PART #	DESCRIPTION
11	PH5502011	CLAMP BRACKET
12	PSB92M	CAP SCREW M12-1.75 X 40
13	PS30M	PHLP HD SCR M8-1.25 X 15
14	PH5502014	HUB
15	PN01M	HEX NUT M6-1
16	PAW08M	HEX WRENCH 8MM
17	PAW10M	HEX WRENCH 10MM
18	PSS01M	SET SCREW M6-1 X 10
19	PN03M	HEX NUT M8-1.25

Model H5502 Parts Breakdown Scroll Tool

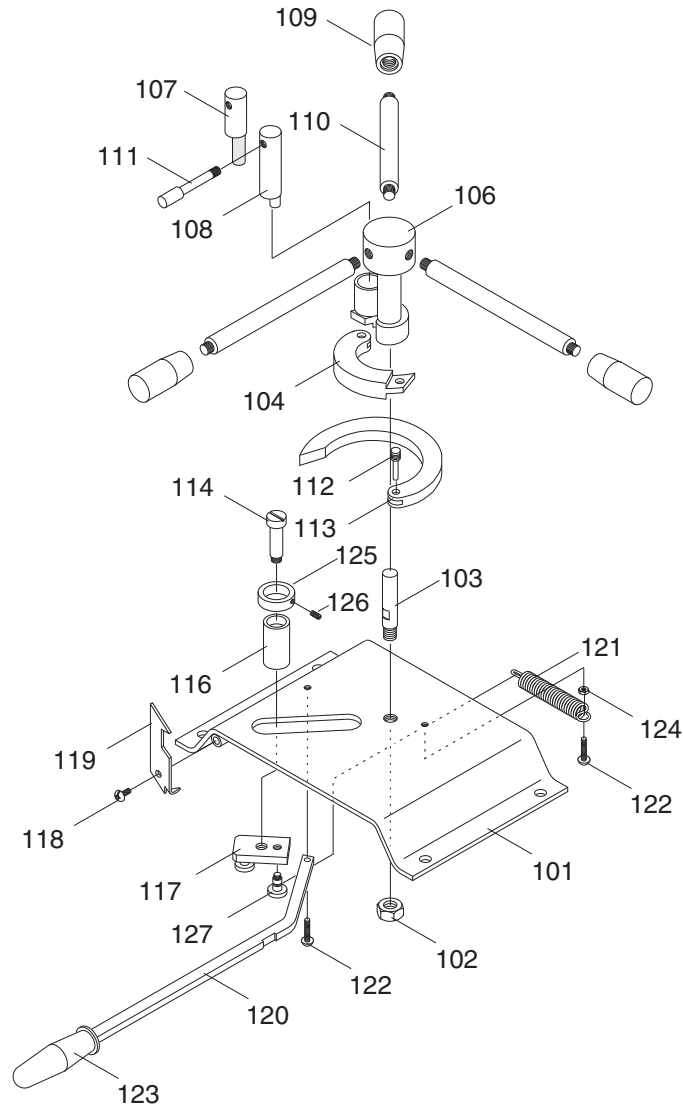

REF	PART #	DESCRIPTION
101	PH5502101	MOUNTING BRACKET
102	PN09M	HEX NUT M12-1.75
103	PH5502103	ARBOR
104	PH5502104	SMALL DIE
106	PH5502106	HUB DIE ASSY.
107	PH5502107	LONG OFFSET SHAFT
108	PH5502108	SHORT OFFSET SHAFT
109	PH5502109	HANDLE GRIP
110	PH5502110	HANDLE BAR
111	PH5502111	CLAMP HANDLE
112	PH5502112	DIE PIN
113	PH5502113	LARGE DIE
114	PH5502114	SPECIAL BOLT M15 X 45
116	PH5502116	GUIDE SLEEVE

REF	PART #	DESCRIPTION
117	PH5502117	GUIDE PLATE
118	PS14M	PHLP HD SCR M6-1 X 12
119	PH5502119	HOOK
120	PH5502120	SQUARE HANDLE BAR
121	PH5502121	SPRING
122	PS26M	PHLP HD SCR M6-1 X 20
123	PH5502123	SQUARE HANDLE GRIP
124	PN01M	HEX NUT M6-1
125	PH5502125	SET COLLAR
126	PSS03M	SET SCREW M6-1 X 8
127	PH5502127	SPRING GUIDE BOLT

Model H5502 Parts Breakdown Bending Tool

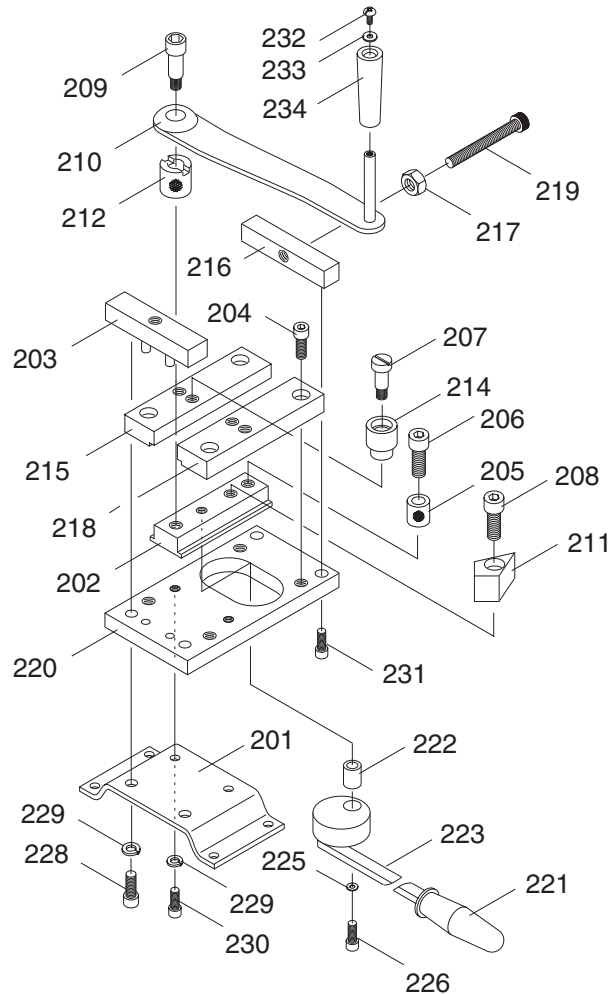

REF	PART #	DESCRIPTION
201	PH5502201	MOUNTING BRACKET
202	PH5502202	SLIDE BLOCK
203	PH5502203	FRONT BLOCK
204	PSB88M	CAP SCREW M10-1.5 X 25
205	PH5502205	PRESS WHEEL
206	PSB59M	CAP SCREW M10-1.5 X 40
207	PH5502207	SPECIAL BOLT M15 X 35
208	PSB77M	CAP SCREW M12-1.75 X 30
209	PH5502209	SPECIAL BOLT M15 X 50
210	PH5502210	CRANK
211	PH5502211	BENDING BLOCK
212	PH5502212	FEED ROLLER
214	PH5502214	GUIDE ROLLER
215	PH5502215	LEFT BLOCK
216	PH5502216	REAR BLOCK
217	PN02M	HEX NUT M10-1.5

REF	PART #	DESCRIPTION
218	PH5502218	RIGHT BLOCK
219	PH5502219	ADJUSTMENT SCREW
220	PH5502220	BASE
221	PH5502221	HANDLE GRIP
222	PH5502222	BUSHING
223	PH5502223	OFFSET HANDLE
225	PW04M	FLAT WASHER 10MM
226	PSB59M	CAP SCREW M10-1.5 X 40
227	PLW06M	LOCK WASHER 10MM
228	PSB84M	CAP SCREW M10-1.5 X 35
229	PLW04M	LOCK WASHER 8MM
230	PSB14M	CAP SCREW M8-1.25 X 20
231	PSB100M	CAP SCREW M8-1.25 X 15
232	PS37M	PHLP HD SCREW M6-1 X 6
233	PW03M	FLAT WASHER 6MM
234	PH5502234	CRANK HANDLE

WARRANTY AND RETURNS

Grizzly Industrial, Inc. warrants every product it sells for a period of **1 year** to the original purchaser from the date of purchase. This warranty does not apply to defects due directly or indirectly to misuse, abuse, negligence, accidents, repairs or alterations or lack of maintenance. This is Grizzly's sole written warranty and any and all warranties that may be implied by law, including any merchantability or fitness, for any particular purpose, are hereby limited to the duration of this written warranty. We do not warrant or represent that the merchandise complies with the provisions of any law or acts unless the manufacturer so warrants. In no event shall Grizzly's liability under this warranty exceed the purchase price paid for the product and any legal actions brought against Grizzly shall be tried in the State of Washington, County of Whatcom.

We shall in no event be liable for death, injuries to persons or property or for incidental, contingent, special, or consequential damages arising from the use of our products.

To take advantage of this warranty, contact us by mail or phone and give us all the details. We will then issue you a "Return Number," which must be clearly posted on the outside as well as the inside of the carton. We will not accept any item back without this number. Proof of purchase must accompany the merchandise.

The manufacturers reserve the right to change specifications at any time because they constantly strive to achieve better quality equipment. We make every effort to ensure that our products meet high quality and durability standards and we hope you never need to use this warranty.

Please feel free to write or call us if you have any questions about the machine or the manual.

Thank you again for your business and continued support. We hope to serve you again soon.

FOLD ALONG DOTTED LINE



Place
Stamp
Here



GRIZZLY INDUSTRIAL, INC.
P.O. BOX 2069
BELLINGHAM, WA 98227-2069



FOLD ALONG DOTTED LINE

Send a Grizzly Catalog to a friend:

Name _____
Street _____
City _____ State _____ Zip _____

TAPE ALONG EDGES--PLEASE DO NOT STAPLE

WARRANTY CARD

Name _____
 Street _____
 City _____ State _____ Zip _____
 Phone Number _____ E-Mail _____ FAX _____
MODEL: _____ Serial # _____ Order _____

The following information is given on a voluntary basis. It will be used for marketing purposes to help us develop better products and services. Of course, all information is strictly confidential.

CUT ALONG DOTTED LINE

1. How did you learn about us?

<input type="checkbox"/> Advertisement <input type="checkbox"/> Catalog <input type="checkbox"/> World Wide Web <input type="checkbox"/> Other _____	<input type="checkbox"/> Friend <input type="checkbox"/> Card Deck
---	---
2. Which of the following magazines do you subscribe to.

<input type="checkbox"/> American Woodworker <input type="checkbox"/> Cabinetmaker <input type="checkbox"/> Family Handyman <input type="checkbox"/> Fine Homebuilding <input type="checkbox"/> Fine Woodworking <input type="checkbox"/> Home Handyman <input type="checkbox"/> Journal of Light Construction <input type="checkbox"/> Old House Journal <input type="checkbox"/> Popular Mechanics <input type="checkbox"/> Popular Science <input type="checkbox"/> Popular Woodworking <input type="checkbox"/> Other _____	<input type="checkbox"/> Practical Homeowner <input type="checkbox"/> Shop Notes <input type="checkbox"/> Today's Homeowner <input type="checkbox"/> WOOD <input type="checkbox"/> Wooden Boat <input type="checkbox"/> Woodshop News <input type="checkbox"/> Woodsmith <input type="checkbox"/> Woodwork <input type="checkbox"/> Woodworker <input type="checkbox"/> Woodworker's Journal <input type="checkbox"/> Workbench
--	---
3. Which of the following woodworking/remodeling shows do you watch?

<input type="checkbox"/> Backyard America <input type="checkbox"/> Home Time <input type="checkbox"/> The American Woodworker <input type="checkbox"/> Other _____	<input type="checkbox"/> The New Yankee Workshop <input type="checkbox"/> This Old House <input type="checkbox"/> Woodwright's Shop
---	---
4. What is your annual household income?

<input type="checkbox"/> \$20,000-\$29,999 <input type="checkbox"/> \$30,000-\$39,999 <input type="checkbox"/> \$40,000-\$49,999 <input type="checkbox"/> \$50,000-\$59,999	<input type="checkbox"/> \$60,000-\$69,999 <input type="checkbox"/> \$70,000-\$79,999 <input type="checkbox"/> \$80,000-\$89,999 <input type="checkbox"/> \$90,000 +
--	---
5. What is your age group?

<input type="checkbox"/> 20-29 <input type="checkbox"/> 30-39 <input type="checkbox"/> 40-49	<input type="checkbox"/> 50-59 <input type="checkbox"/> 60-69 <input type="checkbox"/> 70 +
--	---
6. How long have you been a woodworker?

<input type="checkbox"/> 0 - 2 Years <input type="checkbox"/> 2 - 8 Years	<input type="checkbox"/> 8 - 20 Years <input type="checkbox"/> 20+ Years
--	---
7. How would you rank your woodworking skills?

<input type="checkbox"/> Simple <input type="checkbox"/> Intermediate	<input type="checkbox"/> Advanced <input type="checkbox"/> Master Craftsman
--	--
8. What stationary woodworking tools do you own? Check all that apply.

<input type="checkbox"/> Air Compressor <input type="checkbox"/> Band Saw <input type="checkbox"/> Drill Press <input type="checkbox"/> Drum Sander <input type="checkbox"/> Dust Collector <input type="checkbox"/> Horizontal Boring Machine <input type="checkbox"/> Jointer <input type="checkbox"/> Lathe <input type="checkbox"/> Mortiser	<input type="checkbox"/> Panel Saw <input type="checkbox"/> Planer <input type="checkbox"/> Power Feeder <input type="checkbox"/> Radial Arm Saw <input type="checkbox"/> Shaper <input type="checkbox"/> Spindle Sander <input type="checkbox"/> Table Saw <input type="checkbox"/> Vacuum Veneer Press <input type="checkbox"/> Wide Belt Sander
--	--
9. How many of your woodworking machines are Grizzly? _____
 Other _____
10. Which benchtop tools do you own? Check all that apply.

<input type="checkbox"/> 1" x 42" Belt Sander <input type="checkbox"/> 5" - 8" Drill Press <input type="checkbox"/> 8" Table Saw <input type="checkbox"/> 8" - 10" Bandsaw <input type="checkbox"/> Disc/Belt Sander <input type="checkbox"/> Mini Jointer <input type="checkbox"/> Other _____	<input type="checkbox"/> 6" - 8" Grinder <input type="checkbox"/> Mini Lathe <input type="checkbox"/> 10" - 12" Thickness Planer <input type="checkbox"/> Scroll Saw <input type="checkbox"/> Spindle/Belt Sander
---	---
11. How many of the machines checked above are Grizzly? _____
12. Which portable/hand held power tools do you own? Check all that apply.

13. What machines/supplies would you like Grizzly Industrial to carry?

14. What new accessories would you like Grizzly Industrial to carry?

<input type="checkbox"/> Builders Hardware <input type="checkbox"/> Fasteners <input type="checkbox"/> Other _____	<input type="checkbox"/> Hand Tools <input type="checkbox"/> Wood Components
--	---
15. What other companies do you purchase your tools and supplies from?

16. Do you think your purchase represents good value?
 Yes No
17. Would you recommend Grizzly Industrial to a friend?
 Yes No
18. Would you allow us to use your name as a reference for Grizzly customers in your area? **Note: We never use names more than three times.**
 Yes No
19. Comments: _____

grizzly.com

TOOL WEBSITE

Buy Direct and Save with Grizzly® – Trusted, Proven and a Great Value!

*Visit Our Website Today And Discover Why
Grizzly® Is The Industry Leader!*

- SECURE ORDERING
- ORDERS SHIPPED WITHIN 24 HOURS
- E-MAIL RESPONSE WITHIN ONE HOUR

-OR-

Call Today For A **FREE**
Full Color Catalog

1-800-523-4777

