

READ THIS FIRST



Model G9933

*****IMPORTANT UPDATE*****

For Machines Mfd. Since 05/22
and Owner's Manual Revised 05/09

For questions or help with this product contact Tech Support at (570) 546-9663 or techsupport@grizzly.com

The following changes were recently made since the owner's manual was printed:

- (3) EMERGENCY STOP buttons have been added to machine cabinet.
- Magnetic switch parts have been updated to reflect change made in January, 2004.
- Spindle switch parts have been updated to reflect change made in March, 2006.

Aside from this information, all other content in the owner's manual applies and **MUST** be read and understood for your own safety. **IMPORTANT: Keep this update with the owner's manual for future reference.**

For questions or help, contact our Tech Support at (570) 546-9663 or techsupport@grizzly.com.

Revised Parts

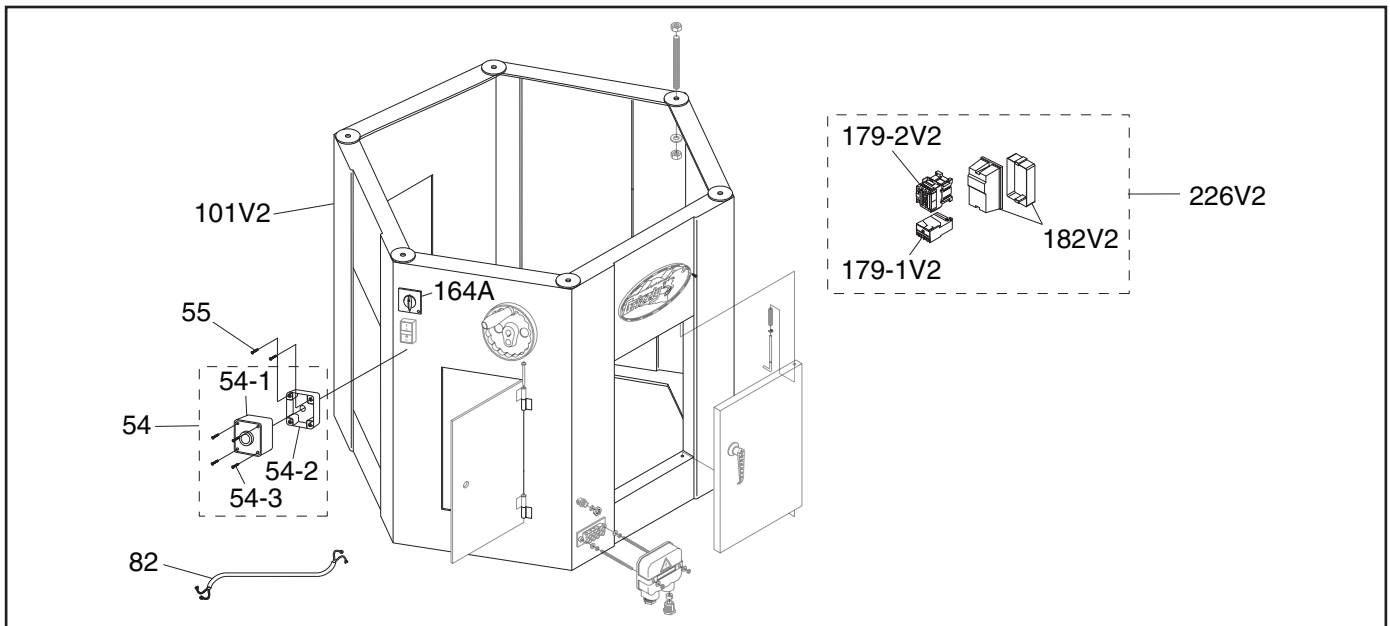

| REF | PART # | DESCRIPTION | REF | PART # | DESCRIPTION |
|------|------------|--------------------------------|---------|--------------|-------------------------------------|
| 54 | P9933054 | EMERGENCY STOP BUTTON ASSEMBLY | 101V2 | P9933101V2 | CABINET FRAME V2.05.22 |
| 54-1 | P9933054-1 | STOP BUTTON KEYON KB2-BE102 | 164A | P9933164A | FWD/REV SWITCH V2.03.06 |
| 54-2 | P9933054-2 | BUTTON BASE | 179-1V2 | P9933179-1V2 | OL RELAY NHD TH-12 12/18 V2.01.04 |
| 54-3 | P9933054-3 | TAP SCREW M4 X 42 | 179-2V2 | P9933179-2V2 | CONTACTOR NHD C-12D10 220V V2.01.04 |
| 55 | P9933055 | PHLP HD SCR M4-.7 X 8 | 182V2 | P9933182V2 | MAG SWITCH BOX NHD V2.01.04 |
| 82 | P9933082 | E-STOP BUTTON CORD 24G 2W 48" | 226V2 | P9933226V2 | MAG SWITCH ASSY NHD V2.01.04 |

COPYRIGHT © MAY, 2022 BY GRIZZLY INDUSTRIAL, INC.

WARNING: NO PORTION OF THIS MANUAL MAY BE REPRODUCED IN ANY SHAPE OR FORM WITHOUT THE WRITTEN APPROVAL OF GRIZZLY INDUSTRIAL, INC.

#CS22357 PRINTED IN TAIWAN

- Secure the fence and guard assemblies to the table with (6) M10-1.5 x 30 hex bolts and 10mm flat washers, as shown in **Figure 1**.

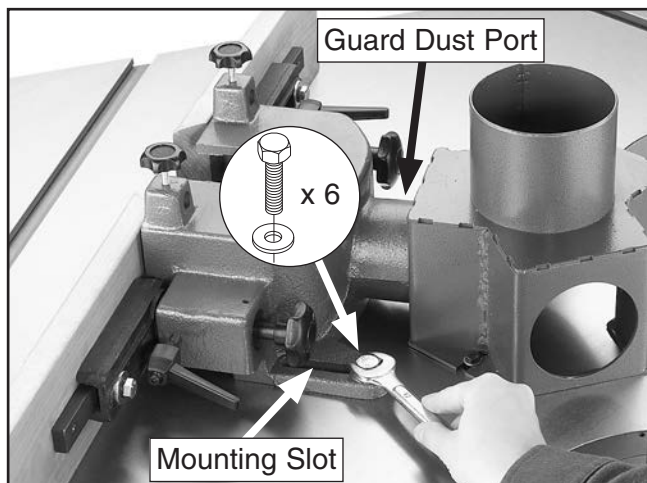

Figure 1. Securing fence assembly and guard to the table.

Dust Collection

⚠ CAUTION

This machine creates a lot of wood chips/dust during operation. Breathing airborne dust on a regular basis can result in permanent respiratory illness. Reduce your risk by wearing a respirator and capturing the dust with a dust-collection system.

Minimum CFM at Each Dust Port: 400 CFM

Do not confuse CFM recommendation with rating of dust collector. To determine CFM at dust port, you must consider these variables: (1) CFM rating of dust collector, (2) hose type and length between dust collector and machine, (3) number of branches or wyes, and (4) amount of other open lines throughout system. Explaining how to calculate these variables is beyond scope of this manual. Consult expert or purchase good dust collection "how-to" book.

Connect an adequate dust collection system to the 4" central dust hood. Make sure the dust hose is supported in a vertical position above the shaper table so that it is not in contact with any other part of the shaper and will not interfere with safe working conditions at each station.

Test Run

Once assembly is complete, test run the machine to ensure it is properly connected to power and safety components are functioning correctly.

If you find an unusual problem during the test run, immediately stop the machine, disconnect it from power, and fix the problem **BEFORE** operating the machine again. The **Troubleshooting** table in the **SERVICE** section of this manual can help.

The Test Run consists of verifying the following: 1) The motors power up and run correctly, and 2) the EMERGENCY STOP button safety features are functioning properly.

⚠ WARNING

Serious injury or death can result from using this machine **BEFORE** understanding its controls and related safety information. **DO NOT** operate, or allow others to operate, machine until the information is understood.

⚠ WARNING

DO NOT start machine until all preceding setup instructions have been performed. Operating an improperly set up machine may result in malfunction or unexpected results that can lead to serious injury, death, or machine/property damage.

To test run machine:

- Clear all setup tools away from machine.
- Press all EMERGENCY STOP buttons in.
- Turn all spindle switches to OFF position.
- Connect machine to power.
- Twist EMERGENCY STOP buttons clockwise until they spring out. This resets switches so machine can start.



6. Press ON button (see **Figure 2**).

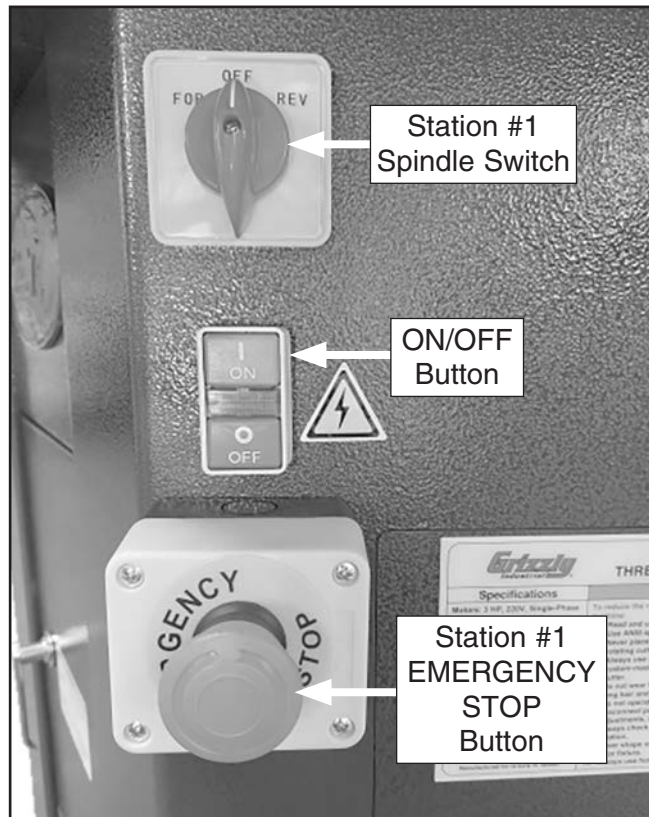

Figure 2. Location of station #1 controls.

8. Press EMERGENCY STOP button at station #1 to turn motor **OFF** (see **Figure 2**).

9. WITHOUT resetting EMERGENCY STOP button, try to start motor. Motor should not start.

— If motor *does not* start, safety feature of EMERGENCY STOP button is working correctly. Proceed to **Step 10**.

— If motor *does* start, immediately turn it **OFF** and disconnect power. Safety feature of EMERGENCY STOP button is NOT working properly and must be replaced before further using machine.

10. Turn station spindle switch to OFF position.

11. Reset EMERGENCY STOP button at station #1.

12. Repeat **Steps 7–11** at station #2, then at station #3.

13. Press OFF button.

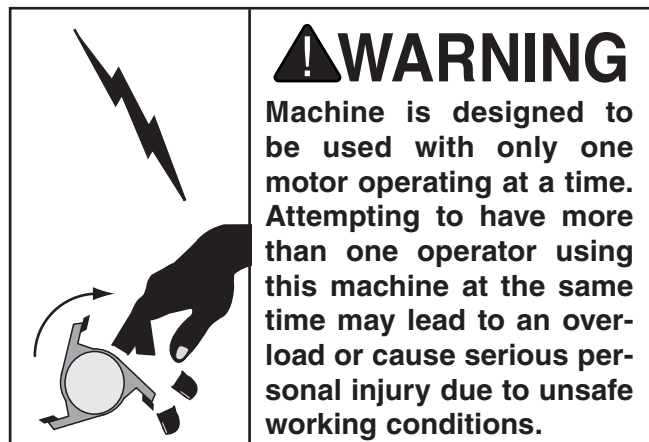

7. At station #1, turn spindle switch to FOR position to turn motor **ON** (see **Figure 2**). Motor should run smoothly and without unusual problems or noises.

— If spindle rotates in opposite direction indicated by spindle switch, turn machine **OFF**, disconnect power, then make sure station motor and magnetic switch are wired correctly (refer to wiring diagrams beginning on **Page 5** of this update).

Recommended Adjustments

For your convenience, the adjustments listed below have been performed at the factory and no further setup is required to operate your machine.

However, because of the many variables involved with shipping, we recommend that you at least verify the following adjustments to ensure the best possible results from your new machine.

Step-by-step instructions for these adjustments can be found on the following referenced pages in the owner's manual.

Factory adjustments that should be verified:

- V-belt tension (**Page 38**).
- Table insert adjustment (**Page 41**).
- Fence alignment (**Page 42**).





SECTION 4: OPERATIONS

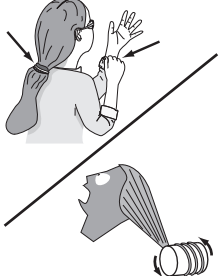
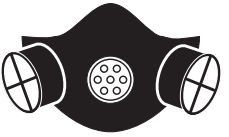

!WARNING
To reduce your risk of serious injury, read this entire manual **BEFORE** using machine.

!WARNING
To reduce risk of eye injury from flying chips or lung damage from breathing dust, **always wear safety glasses and a respirator when operating this machine.**



!WARNING
Keep hair, clothing, and jewelry away from moving parts at all times. Entanglement can result in death, amputation, or severe crushing injuries!

!CAUTION
No list of safety guidelines can be complete. Every shop environment is different. Always consider safety first, as it applies to individual working conditions. Use machinery with caution/respect. Failure to do so could result in serious personal injury, damage to equipment, or poor work results.

NOTICE
If you are inexperienced with this machine type, **WE STRONGLY RECOMMEND** that you seek training outside of this manual. Read books/magazines or get formal training before beginning projects. Regardless of content, Grizzly Industrial will not be held liable for accidents due to lack of training.

Power Controls

Power ON/OFF Switch

There is one power ON/OFF switch for the entire machine located on the cabinet (see **Figure 3**). When this switch is turned **ON**, power flows to each of the station spindle switches.

Spindle Switch

Each station of your shaper is equipped with an independent spindle switch (see **Figure 3**) that controls the spindle rotation. When there is power flowing to the machine, the spindle switch is used to select the direction of spindle rotation or to stop the rotation.

EMERGENCY STOP Button

There is an EMERGENCY STOP button at each station (see **Figure 3**) to stop all three spindles. These buttons can be activated by a knee when hands are full or when the ON/OFF switch or spindle switches cannot be reached.

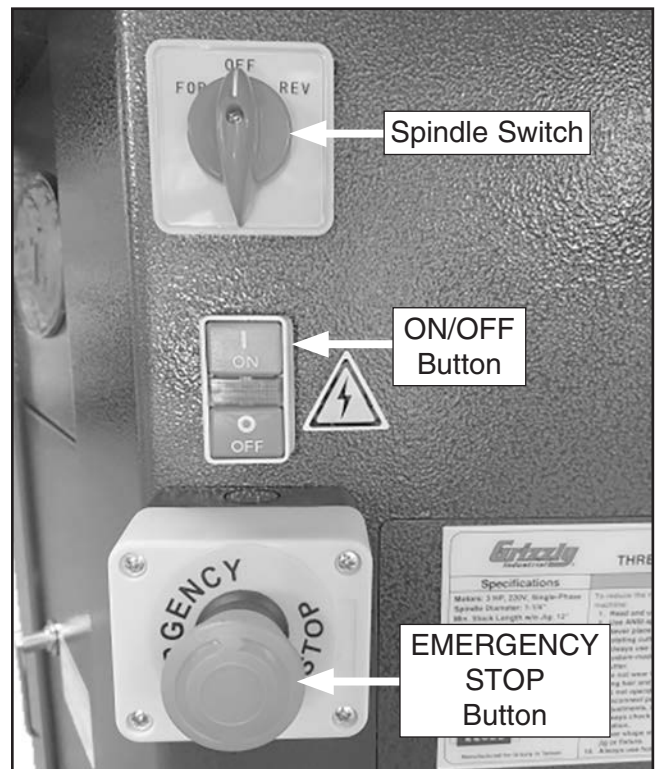
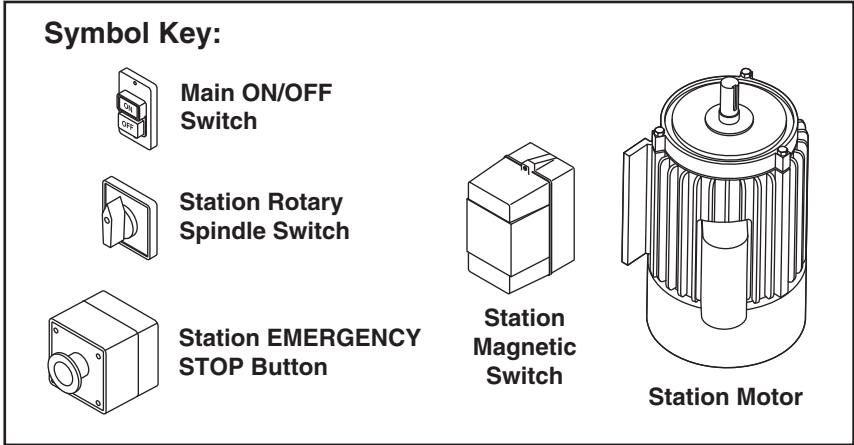
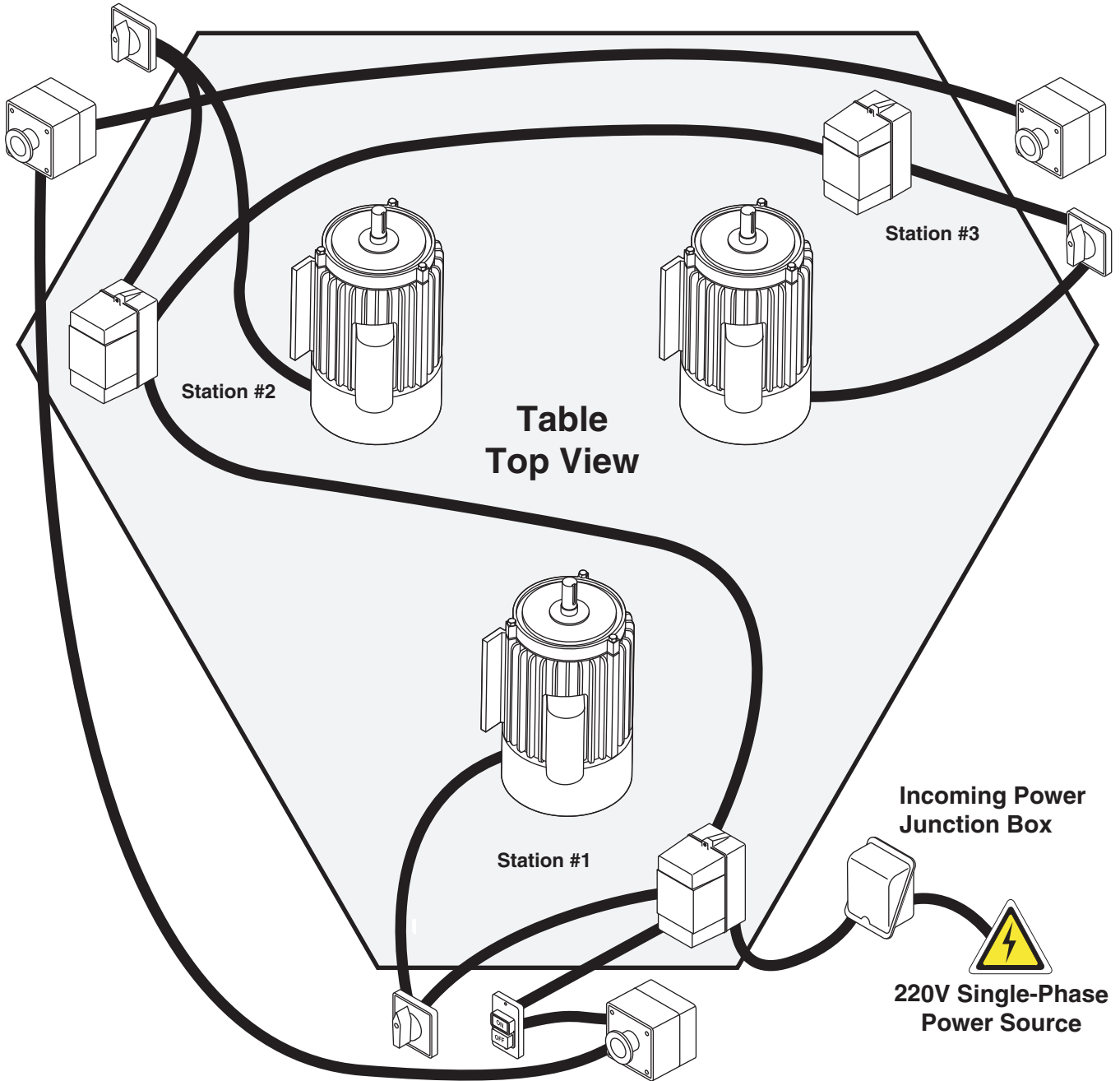

Figure 3. Power controls (station #1 shown).



Wiring Overview



Wiring Diagram (A)

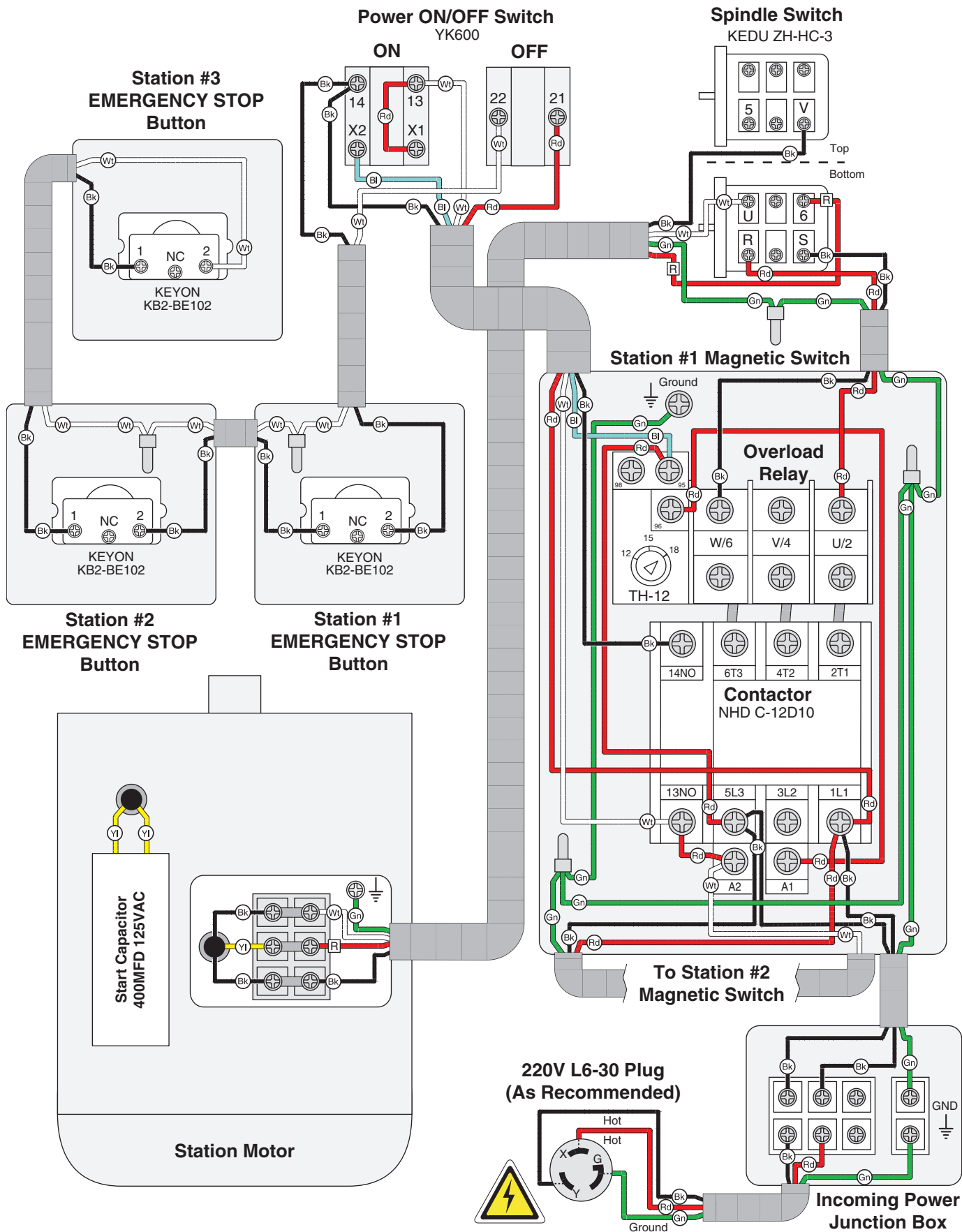

Wiring Diagram (B)

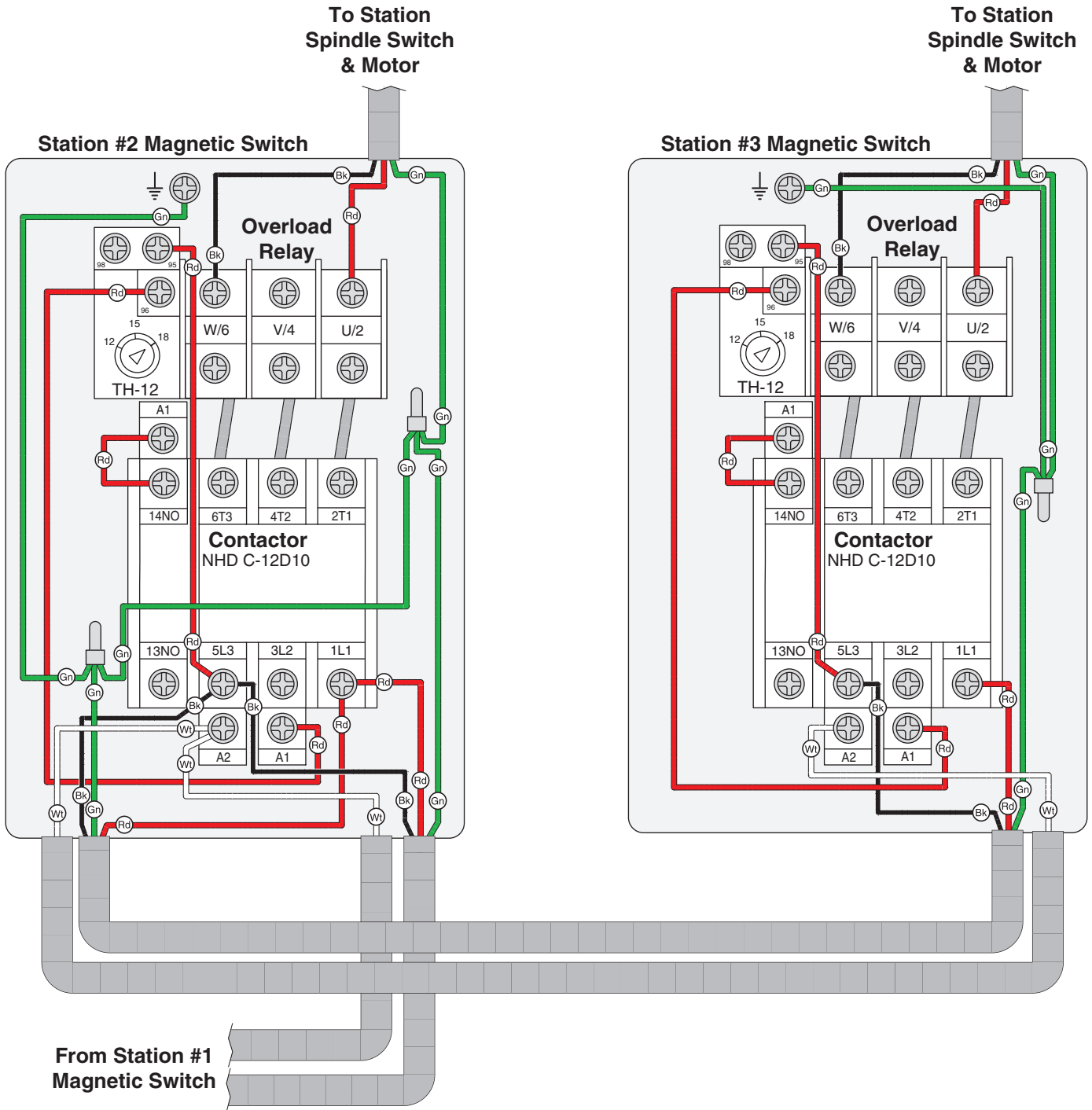

grizzly.com[®]

TOOL WEBSITE

Buy Direct and Save with Grizzly[®] – Trusted, Proven and a Great Value!
~Since 1983~

*Visit Our Website Today For
Current Specials!*

**ORDER
24 HOURS A DAY!
1-800-523-4777**



READ THIS FIRST



Model G9933

*****IMPORTANT UPDATE*****

For Machines Mfd. Since 12/16
and Owner's Manual Revised 05/09

For questions or help with this product contact Tech Support at (570) 546-9663 or techsupport@grizzly.com

The following change was recently made to this machine since the owner's manual was printed:

- Added a front guard to each spindle guard assembly.

Aside from this information, all other content in the owner's manual applies and **MUST** be read and understood for your own safety. **IMPORTANT: Keep this update with the owner's manual for future reference.**

For questions or help, contact our Tech Support at (570) 546-9663 or techsupport@grizzly.com.

New Parts

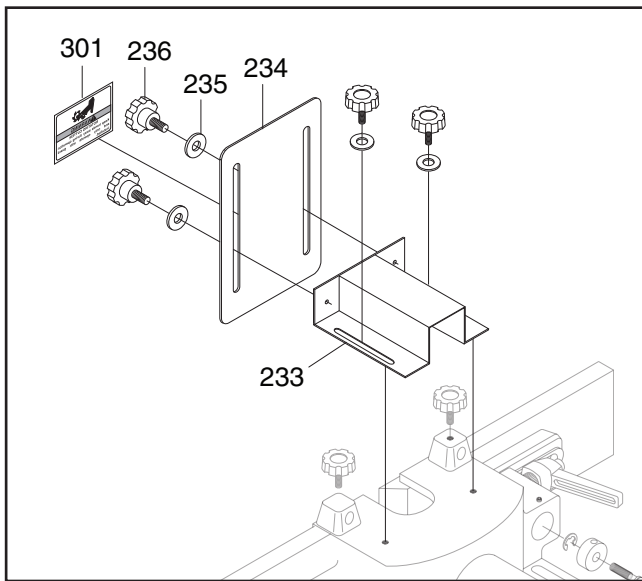

| REF | PART # | DESCRIPTION |
|-----|----------|-----------------------------|
| 233 | P9933233 | FRONT GUARD EXTENSION PLATE |
| 234 | P9933234 | FRONT GUARD |
| 235 | P9933235 | FLAT WASHER 6MM |
| 236 | P9933236 | KNOB BOLT M6-1 X 16 6-LOBE |
| 301 | P9933301 | CUTTER HAZARD LABEL |

New Inventory

| Inventory | Qty |
|---------------------------------------|-----|
| A. Front Guards | 3 |
| B. Front Guard Extension Plates | 3 |
| C. Flat Washers 6mm | 12 |
| D. Knob Bolts M6-1 x 16..... | 12 |

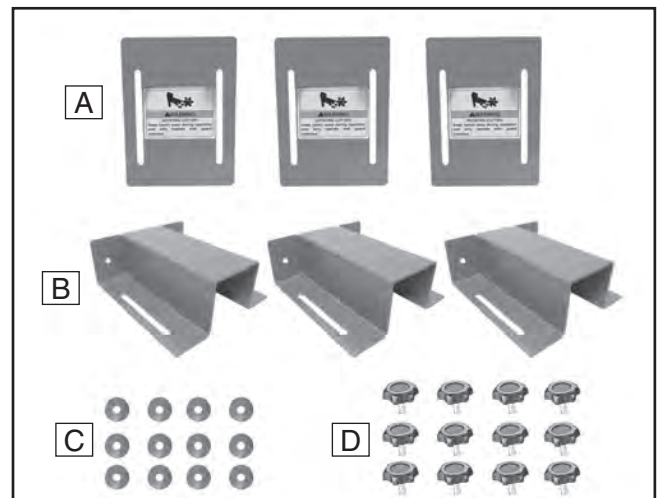

Note: The inventory items above are pre-installed on the fence and guard assemblies. Refer to the **Assembly** section in the owner's manual for instructions on assembling the fence and guard assemblies.

COPYRIGHT © MAY, 2017 BY GRIZZLY INDUSTRIAL, INC.
WARNING: NO PORTION OF THIS MANUAL MAY BE REPRODUCED IN ANY SHAPE OR FORM WITHOUT THE WRITTEN APPROVAL OF GRIZZLY INDUSTRIAL, INC.
#BL18964 PRINTED IN TAIWAN

Front Guard Positioning

The front guard helps protect the user from additional exposure to the cutter and any chips thrown by it. To minimize the risk of injury, the front guard must be adjusted so it encloses as much of the spindle area as possible, while still allowing the workpiece to pass through the cut. Typically this means the front guard is positioned to just clear the top of the workpiece.

To position the front guard (see **Figure 44**), loosen the top knob bolts and slide the extension plate in or out, then loosen the front knob bolts and raise or lower the front guard as needed. Tighten the knob bolts to secure the setting.

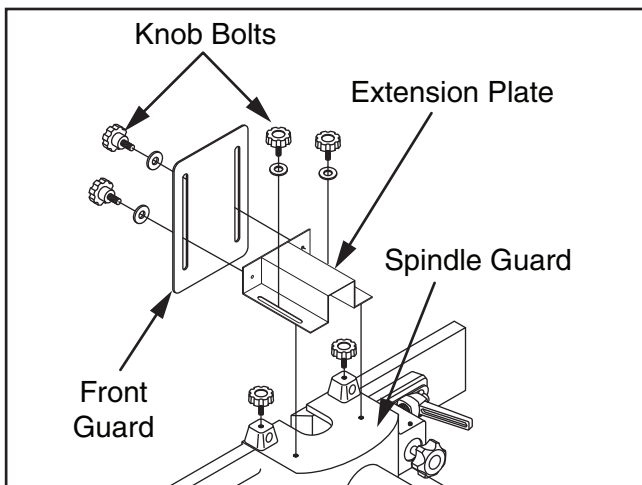

Figure 44. Extension plate and front guard attached to spindle guard.

| | |
|--|---|
|  | <p>! WARNING</p> <p>All guards MUST be installed on your shaper before operating it. Shapers can quickly cause serious injury if some kind of guard is not used. To reduce your risk of injury, read and follow the entire Owner's Manual carefully and do additional research on shop-made guards and safety jigs.</p> |
|--|---|



Grizzly **Industrial, Inc.** ®

MODEL G9933 THREE SPINDLE SHAPER OWNER'S MANUAL



COPYRIGHT © JANUARY, 2002 BY GRIZZLY INDUSTRIAL, INC., REVISED MAY, 2009 (TS)
**WARNING: NO PORTION OF THIS MANUAL MAY BE REPRODUCED IN ANY SHAPE
OR FORM WITHOUT THE WRITTEN APPROVAL OF GRIZZLY INDUSTRIAL, INC.**
(FOR MACHINES MANUFACTURED SINCE 1/02) #TR3552 PRINTED IN TAIWAN



WARNING!

This manual provides critical safety instructions on the proper setup, operation, maintenance and service of this machine/equipment.

Failure to read, understand and follow the instructions given in this manual may result in serious personal injury, including amputation, electrocution or death.

The owner of this machine/equipment is solely responsible for its safe use. This responsibility includes but is not limited to proper installation in a safe environment, personnel training and usage authorization, proper inspection and maintenance, manual availability and comprehension, application of safety devices, blade/cutter integrity, and the usage of personal protective equipment.

The manufacturer will not be held liable for injury or property damage from negligence, improper training, machine modifications or misuse.



WARNING!

Some dust created by power sanding, sawing, grinding, drilling, and other construction activities contains chemicals known to the State of California to cause cancer, birth defects or other reproductive harm. Some examples of these chemicals are:

- **Lead from lead-based paints.**
- **Crystalline silica from bricks, cement and other masonry products.**
- **Arsenic and chromium from chemically-treated lumber.**

Your risk from these exposures varies, depending on how often you do this type of work. To reduce your exposure to these chemicals: Work in a well ventilated area, and work with approved safety equipment, such as those dust masks that are specially designed to filter out microscopic particles.

Table of Contents

| | | | |
|---|-----------|---|-----------|
| INTRODUCTION | 2 | SECTION 5: ACCESSORIES | 34 |
| Manual Accuracy | 2 | SECTION 6: MAINTENANCE..... | 36 |
| Contact Info..... | 2 | Schedule | 36 |
| Machine Description | 2 | Cleaning & Protecting..... | 36 |
| Identification | 3 | Lubrication | 37 |
| Machine Data Sheet | 4 | V-Belt Tensioning & Replacement..... | 38 |
| SECTION 1: SAFETY | 6 | SECTION 7: SERVICE | 39 |
| Safety Instructions for Machinery | 6 | Troubleshooting | 39 |
| Additional Safety Instructions for Shapers..... | 8 | Table Insert Adjustment..... | 41 |
| SECTION 2: CIRCUIT REQUIREMENTS | 9 | Spindle Replacement..... | 41 |
| 220V Single-Phase Operation | 9 | Aligning Fence | 42 |
| Power Connection..... | 10 | Spindle Cartridge/Bearing Replacement | 43 |
| SECTION 3: SETUP | 11 | SECTION 8: WIRING..... | 46 |
| Needed for Setup..... | 11 | Wiring Safety Instructions | 46 |
| Unpacking | 11 | Wiring Overview..... | 47 |
| Inventory | 12 | Wiring Diagram (A) | 48 |
| Cleanup..... | 13 | Wiring Diagram (B) | 49 |
| Site Considerations..... | 14 | SECTION 9: PARTS | 50 |
| Lifting & Placing Shaper | 15 | Motor & Spindle | 50 |
| Mounting to Shop Floor | 15 | Cabinet & Table | 52 |
| Assembly | 16 | Fence & Guard Assembly..... | 53 |
| Dust Collection..... | 17 | Label Placement | 54 |
| Test Run | 17 | WARRANTY AND RETURNS | 57 |
| Recommended Adjustments..... | 18 | | |
| SECTION 4: OPERATIONS | 19 | | |
| Power Controls | 19 | | |
| Operation Overview | 20 | | |
| Stock Inspection & Requirements..... | 20 | | |
| Cutter Rotation Direction | 21 | | |
| Cutter Height..... | 21 | | |
| Hold-Downs | 22 | | |
| Fence Adjustment..... | 22 | | |
| Changing Speeds | 23 | | |
| Table Inserts | 25 | | |
| Cutter Installation..... | 25 | | |
| Cutter Safety Guard..... | 27 | | |
| Edge Cutting | 28 | | |
| Cutting Rabbets | 29 | | |
| Shaping Small Stock..... | 30 | | |
| Rub Collars | 31 | | |
| Irregular Shaping | 32 | | |
| Pattern Work..... | 32 | | |

INTRODUCTION

Manual Accuracy

We are proud to offer this manual with your new machine! We've made every effort to be exact with the instructions, specifications, drawings, and photographs of the machine we used when writing this manual. However, sometimes errors do happen and we apologize for them.

Also, owing to our policy of continuous improvement, **your machine may not exactly match the manual**. If you find this to be the case, and the difference between the manual and machine leaves you in doubt, check our website for the latest manual update or call technical support for help.

Before calling, find the manufacture date of your machine by looking at the date stamped into the machine ID label (see below). This will help us determine if the manual version you received matches the manufacture date of your machine.

| | | | |
|---|---------------|---|--|
|  | | MODEL GXXXX MACHINE NAME | |
| SPECIFICATIONS | | ▲ WARNING! | |
| Motor: | | Manufacture Date of Your Machine ing this machine: operation, is and respirator. sted/setup and quit before starting. | |
| Specification: | | | |
| Specification: | | | |
| Specification: | | | |
| Weight: | | | |
| | Date | 4. Make sure the motor has stopped and disconnect power before adjustments, maintenance, or service. | |
| | Serial Number | 5. DO NOT expose to rain or dampness. | |
| Manufactured for Grizzly in Taiwan | | 6. DO NOT modify this machine in any way. | |
| | | 7. DO NOT remove safety guards. | |
| | | 8. Never leave machine running unattended. | |
| | | 9. DO NOT operate under the influence of drugs or alcohol. | |
| | | 10. Maintain machine carefully to prevent accidents. | |

For your convenience, we post all available manuals and manual updates for free on our website at www.grizzly.com. Any updates to your model of machine will be reflected in these documents as soon as they are complete.

Contact Info

We stand behind our machines. If you have any service questions, parts requests or general questions about the machine, please call or write us at the location listed below.

Grizzly Industrial, Inc.
1203 Lycoming Mall Circle
Muncy, PA 17756
Phone: (570) 546-9663
Fax: (800) 438-5901
E-Mail: techsupport@grizzly.com

If you have any comments regarding this manual, please write to us at the address below:

Grizzly Industrial, Inc.
% Technical Documentation Manager
P.O. Box 2069
Bellingham, WA 98227-2069
Email: manuals@grizzly.com

Machine Description

The shaper is a versatile woodworking machine used to make contoured cuts on the edge of the workpiece. This is accomplished by passing the stock along the fence and past the spinning cutter.

Cutters are available in many different profiles for a wide variety of cutting applications, such as cabinets, doors, moulding, curved pieces, and freehand or pattern cutting.

The Model G9933 is a three-station shaper that is typically used in a production shop because three different cutters can be mounted and available for use at the same time.



Identification

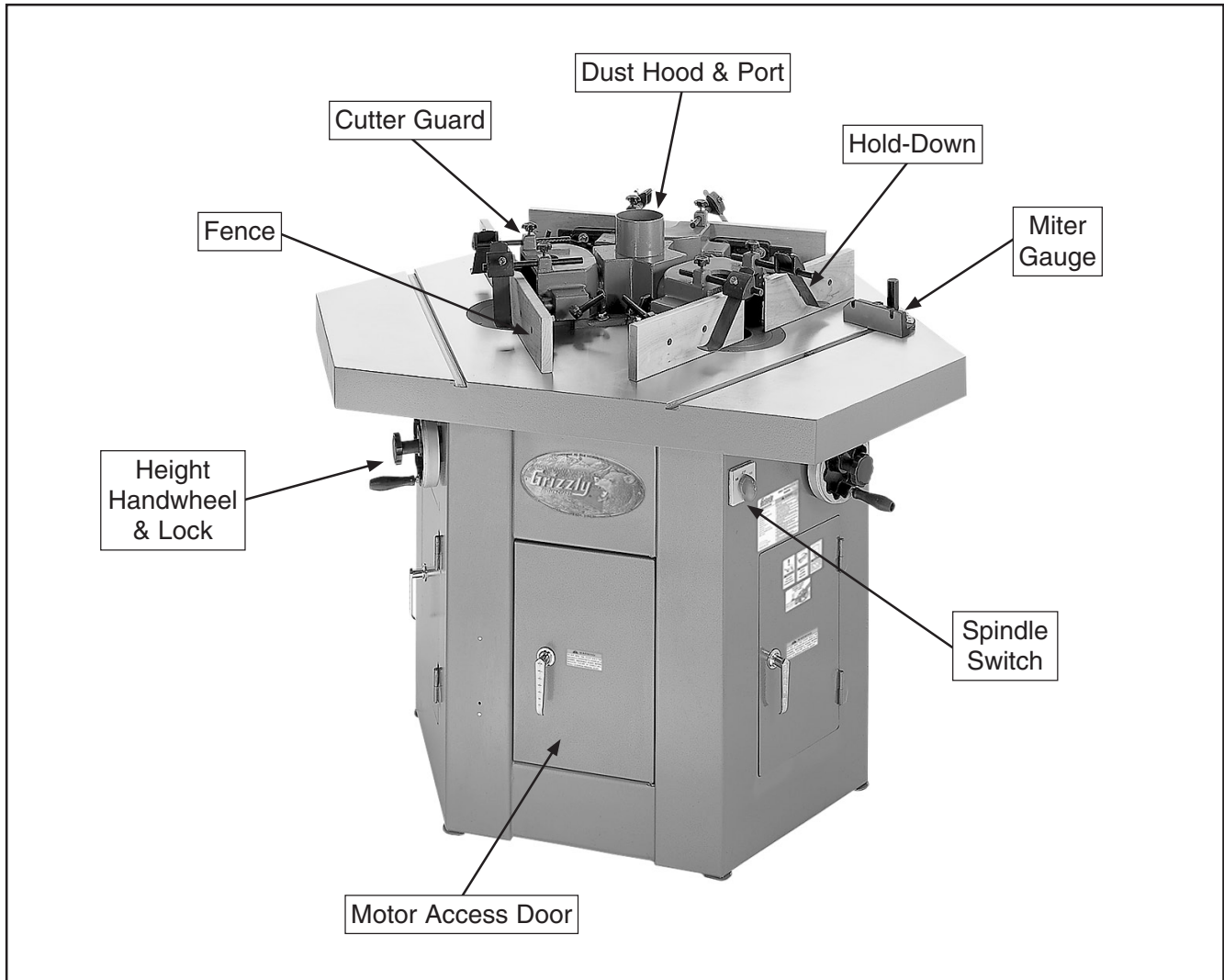

Figure 1. Model G9933 identification.

NOTICE

If you have never used this type of machine or equipment before, WE STRONGLY RECOMMEND that you read books, review industry trade magazines, or get formal training before beginning any projects. Regardless of the content in this section, Grizzly Industrial will not be held liable for accidents caused by lack of training.





MACHINE DATA SHEET

Customer Service #: (570) 546-9663 · To Order Call: (800) 523-4777 · Fax #: (800) 438-5901

MODEL G9933 THREE SPINDLE SHAPER

Product Dimensions:

Weight..... 1185 lbs.
 Length/Width/Height..... 45-1/2 x 52-1/8 x 45 in.
 Foot Print (Length/Width)..... 37-1/4 x 34-1/4 in.

Shipping Dimensions:

Type..... Wood Crate
 Content..... Machine
 Weight..... 1260 lbs.
 Length/Width/Height..... 50 x 54 x 43 in.

Electrical:

Switch..... Magnetic with Thermal Overload Protector
 Switch Voltage..... 220V
 Minimum Circuit Size..... 30 amp
 Plug Included..... No

Motors:

Main

Type..... TEFC Capacitor Start Induction
 Horsepower..... 3 HP
 Voltage..... 220V
 Rewired..... 220V
 Phase..... Single
 Amps..... 18A
 Speed..... 3450 RPM
 Cycle..... 60 Hz
 Number Of Speeds..... 1
 Power Transfer Belt Drive
 Bearings..... Shielded and Lubricated

Main Specifications:

Operation Info

Max. Cutter Height..... 4-9/16 in.
 Max. Cutter Dia..... 6 in.
 Spindle Sizes..... 1-1/4 in.
 Spindle Lengths..... 5-7/8 in.
 Exposed Spindle Length..... 4 in.
 Spindle Cap Under The Nut..... 4-1/2 in.
 Spindle Speeds..... 7000, 10000 RPM
 Spindle Travel..... 4 in.
 Spindle Openings..... 3-1/4, 6-1/4, 8-1/4 in.



Table Info

| | |
|---------------------------------|-------------------|
| No. Of Table Inserts..... | 2 |
| Table Insert Sizes I.D..... | 3-1/8, 6-1/4 in. |
| Table Insert Sizes O.D..... | 7-1/4, 9-3/16 in. |
| Table Counterbore Diameter..... | 8-1/4 in. |
| Table Counterbore Depth..... | 3/8 in. |
| Table Size Length..... | 28-1/4 in. |
| Table Size Width..... | 21-3/4 in. |
| Table Size Thickness..... | 3-1/16 in. |
| Floor To Table Height..... | 35 in. |
| Table Fence Length..... | 27-1/8 in. |
| Table Fence Width..... | 13/16 in. |
| Table Fence Height..... | 3-7/8 in. |

Miter Gauge Info

| | |
|------------------------------|--------------|
| Miter Angle..... | 90 - 30 deg. |
| Miter Gauge Slot Type..... | T-Slot |
| Miter Gauge Slot Width..... | 3/4 in. |
| Miter Gauge Slot Height..... | 7/8 in. |

Construction

| | |
|--------------------------|-----------------------|
| Table Const..... | Ground Cast Iron |
| Base Const..... | Pre-Formed Steel |
| Body Assembly Const..... | Cast Iron |
| Cabinet Const..... | Pre-Formed Steel |
| Fence Const..... | Cast Iron with Wood |
| Miter Gauge Const..... | Cast Iron |
| Guard Const..... | Cast Iron |
| Spindle Bearings..... | Sealed and Lubricated |
| Paint..... | Epoxy |

Other

| | |
|------------------------|-------|
| No. Of Dust Ports..... | 1 |
| Dust Port Size..... | 4 in. |

Other Specifications:

| | |
|------------------------------|------------------------------|
| Country Of Origin | Taiwan |
| Warranty | 1 Year |
| Serial Number Location | ID Label on Front of Cabinet |
| Assembly Time | 60 minutes |

Features:

- 3 Separate Motors
- 3 Micro Adjustable Fences
- 3 Magnetic Reversing Switches
- Spindles Include Spacer and Nuts
- Vertical Spindle Lock
- Spindle Turning Lock
- Heavy Duty Miter Gauge Included
- Includes Service Wrenches and Tool Box
- Router Bit Spindle Available as an Option
- 3/4" and 1/2" Spindles Available as an Option
- Three 4" Dust Ports
- Two Spindle Speeds-7,000 & 10,000 RPM



SECTION 1: SAFETY

WARNING

For Your Own Safety, Read Instruction Manual Before Operating this Machine

The purpose of safety symbols is to attract your attention to possible hazardous conditions. This manual uses a series of symbols and signal words intended to convey the level of importance of the safety messages. The progression of symbols is described below. Remember that safety messages by themselves do not eliminate danger and are not a substitute for proper accident prevention measures.



Indicates an imminently hazardous situation which, if not avoided, WILL result in death or serious injury.



Indicates a potentially hazardous situation which, if not avoided, COULD result in death or serious injury.



Indicates a potentially hazardous situation which, if not avoided, MAY result in minor or moderate injury. It may also be used to alert against unsafe practices.

NOTICE

This symbol is used to alert the user to useful information about proper operation of the machine.

WARNING

Safety Instructions for Machinery

- 1. READ ENTIRE MANUAL BEFORE STARTING.** Operating machine before reading the manual greatly increases the risk of injury.
- 2. ALWAYS USE ANSI APPROVED SAFETY GLASSES WHEN OPERATING MACHINERY.** Everyday eyeglasses only have impact resistant lenses—they are NOT safety glasses.
- 3. ALWAYS WEAR A NIOSH APPROVED RESPIRATOR WHEN OPERATING MACHINERY THAT PRODUCES DUST.** Most types of dust (wood, metal, etc.) can cause severe respiratory illnesses.
- 4. ALWAYS USE HEARING PROTECTION WHEN OPERATING MACHINERY.** Machinery noise can cause permanent hearing loss.
- 5. WEAR PROPER APPAREL. DO NOT** wear loose clothing, gloves, neckties, rings, or jewelry that can catch in moving parts. Wear protective hair covering to contain long hair and wear non-slip footwear.
- 6. NEVER OPERATE MACHINERY WHEN TIRED OR UNDER THE INFLUENCE OF DRUGS OR ALCOHOL.** Be mentally alert at all times when running machinery.



WARNING

Safety Instructions for Machinery

7. **ONLY ALLOW TRAINED AND PROPERLY SUPERVISED PERSONNEL TO OPERATE MACHINERY.** Make sure operation instructions are safe and clearly understood.
8. **KEEP CHILDREN/VISITORS AWAY.** Keep all children and visitors away from machinery. When machine is not in use, disconnect it from power, lock it out, or disable the switch to make it difficult for unauthorized people to start the machine.
9. **UNATTENDED OPERATION.** Leaving machine unattended while its running greatly increases the risk of an accident or property damage. Turn machine **OFF** and allow all moving parts to come to a complete stop before walking away.
10. **DO NOT USE IN DANGEROUS ENVIRONMENTS.** DO NOT use machinery in damp, wet locations, or where any flammable or noxious fumes may exist.
11. **KEEP WORK AREA CLEAN AND WELL LIGHTED.** Clutter and dark shadows may cause accidents.
12. **USE A GROUNDED POWER SUPPLY RATED FOR THE MACHINE AMPERAGE.** Grounded cords minimize shock hazards. Operating machine on an incorrect size of circuit increases risk of fire.
13. **ALWAYS DISCONNECT FROM POWER SOURCE BEFORE SERVICING MACHINERY.** Make sure switch is in OFF position before reconnecting.
14. **MAINTAIN MACHINERY WITH CARE.** Keep blades sharp and clean for best and safest performance. Follow instructions for lubricating and changing accessories.
15. **MAKE SURE GUARDS ARE IN PLACE AND WORK CORRECTLY BEFORE USING MACHINERY.**
16. **REMOVE CHUCK KEYS OR ADJUSTING TOOLS.** Make a habit of never leaving chuck keys or other adjustment tools in/on the machine—especially near spindles!
17. **DAMAGED MACHINERY.** Check for binding or misaligned parts, broken parts, loose bolts, other conditions that may impair machine operation. Always repair or replace damaged parts before operation.
18. **DO NOT FORCE MACHINERY.** Work at the speed for which the machine or accessory was designed.
19. **SECURE WORKPIECE.** Use clamps or a vise to hold the workpiece when practical. A secured workpiece protects your hands and frees both hands to operate the machine.
20. **DO NOT OVERREACH.** Maintain stability and balance at all times when operating machine.
21. **MANY MACHINES CAN EJECT WORKPIECES TOWARD OPERATOR.** Know and avoid conditions that cause the workpiece to "kickback."
22. **STABLE MACHINE.** Machines that move during operations greatly increase the risk of injury and loss of control. Verify machines are stable/secure and mobile bases (if used) are locked before starting.
23. **CERTAIN DUST MAY BE HAZARDOUS** to the respiratory systems of people and animals, especially fine dust. Be aware of the type of dust you are exposed to and always wear a respirator designed to filter that type of dust.
24. **EXPERIENCING DIFFICULTIES.** If at any time you are experiencing difficulties performing the intended operation, stop using the machine! Contact our Technical Support Department at (570) 546-9663.



WARNING

Additional Safety Instructions for Shapers

- 1. HAND POSITIONING.** Never place hands directly over, behind, or in front of the spinning cutter to prevent accidental contact. Always keep hands at least 12" away from the cutter while operating.
- 2. KICKBACK HAZARD.** Kickback can cause the operator or bystanders to be struck by flying stock or the operator's hands can be pulled into the cutter during kickback. Always confirm which direction the cutter is rotating before moving the workpiece into the cutting path. Always move the workpiece against the rotation of the cutter or kickback can occur.
- 3. SAFETY GUARDS & DEVICES.** DO NOT remove the protective cutter guard while operating. Use a fixture, jig, or hold-down device to reduce the risk of kickback or injury.
- 4. CUTTER CLEARANCE.** If the spinning cutter comes in contact with the cutter guard, fence, or other machine parts, operator injury or machine damage could result. With the machine disconnected from power and wearing hand protection, rotate the cutter by hand to make sure there is proper clearance before beginning operation.
- 5. RUB COLLARS.** To prevent the workpiece slipping past the cutter and possibly resulting in personal injury, NEVER start out at a corner when shaping contoured work and using a rub collar. Refer to **Rub Collars** on **Page 31** of this manual for detailed instructions.
- 6. BLIND CUT WHENEVER POSSIBLE.** This keeps the knives on the underside of the workpiece when cutting, which reduces the risk of accidental contact.
- 7. SHORT STOCK.** To reduce the risk of the operator's hands contacting the spinning cutter, DO NOT shape stock shorter than 12" without special safety fixtures or jigs. When possible, shape longer stock, then cut to size.
- 8. MULTIPLE LIGHT PASSES.** To avoid overloading the machine and cutter, never attempt to remove too much material in one pass. It is safer and likely to produce higher quality work if you allow the cutter to remove material with multiple light passes.
- 9. WORKPIECE CONDITION.** Always inspect the workpiece before beginning operation for knots, holes, or foreign objects such as nails, staples, etc., that can cause kickback or flying debris to be thrown at the operator. If you are not sure about the condition of the workpiece, DO NOT use it!
- 10. PUSH STICKS.** Although using push sticks as a safety device is usually a good idea, exercise caution. If the push stick comes in contact with the cutter during operation, it can fly out of your hand at a high rate of speed, causing serious personal injury. Use fixtures, jig, and hold-down devices as a safer alternative.
- 11. SECURE COMPONENTS.** Always make sure the cutter or bits, fence, spindle height lock knob, and other safety devices are tight before beginning operation to prevent unexpected movement of these parts that could result in operator injury.
- 12. FEED RATE.** Never force the workpiece through the cutter—let the cutter do the work! Excessive force could result in poor results and can increase the chance of kickback.

WARNING

Like all machinery there is potential danger when operating this machine. Accidents are frequently caused by lack of familiarity or failure to pay attention. Use this machine with respect and caution to decrease the risk of operator injury. If normal safety precautions are overlooked or ignored, serious personal injury may occur.



SECTION 2: CIRCUIT REQUIREMENTS

220V Single-Phase Operation

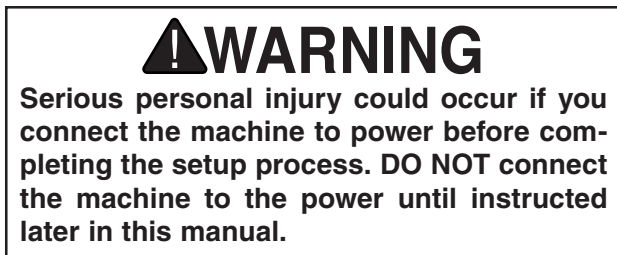
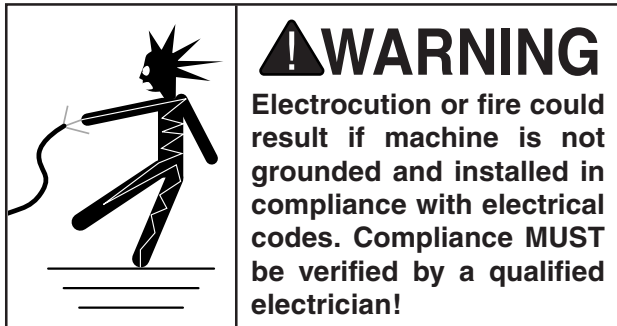

Full Load Amperage Draw

This machine draws the following amps under maximum load:

Amp Draw..... 18 Amps

Power Supply Circuit Requirements

The power supply circuit for your machine **MUST** be grounded and rated for the amperage given below. Never replace a circuit breaker on an existing circuit with one of higher amperage without consulting a qualified electrician to ensure compliance with wiring codes. **If you are unsure about the wiring codes in your area or you plan to connect your machine to a shared circuit, consult a qualified electrician.**

Minimum Circuit Size.....30 Amps

Minimum Cord Requirements

For 220V connection, use a stranded-copper flexible cord that meets the minimum requirements listed below, does not exceed 50 ft., and has an insulation type that starts with "S." A qualified electrician **MUST** determine the best cord to use in your environment depending on exposure to moisture, heat, and oils.

220V Single-Phase.....12/3 AWG, 300VAC

Power Connection Device

The type of plug required to connect your machine to power depends on the type of service you currently have or plan to install. We recommend using the plug shown in **Figure 2**.

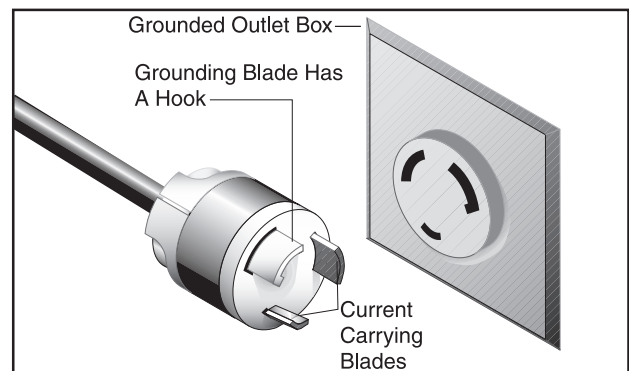

Figure 2. NEMA L6-30 plug and receptacle.

Extension Cords

Using extension cords may reduce the life of the motor. Instead, place the machine near a power source. If you must use an extension cord:

- Use at least a 12 gauge cord that does not exceed 50 feet in length!
- The extension cord must also have a ground wire and plug pin.
- A qualified electrician **MUST** size cords over 50 feet long to prevent motor damage.



Power Cord Connection

⚠️ WARNING

Serious personal injury could occur if you connect the machine to power before completing the setup process. **DO NOT** connect the machine to the power until instructed later in this manual.

To connect the power cord to the shaper:

1. Read and understand the warnings and instructions covered in the **Circuit Requirements** section on **Page 9**.
2. Remove the electrical box cover located on the outside base of the machine (see **Figure 3**).

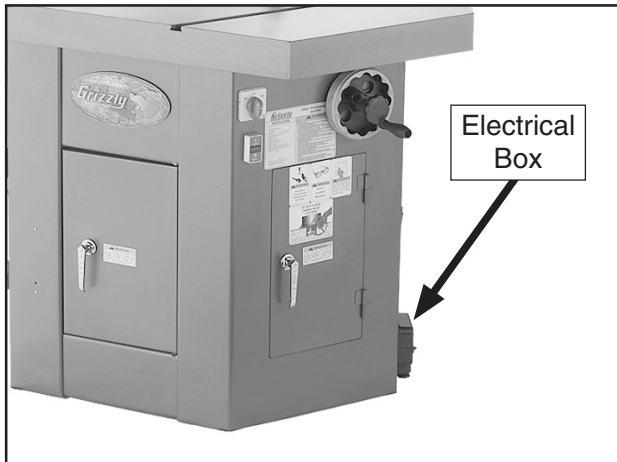
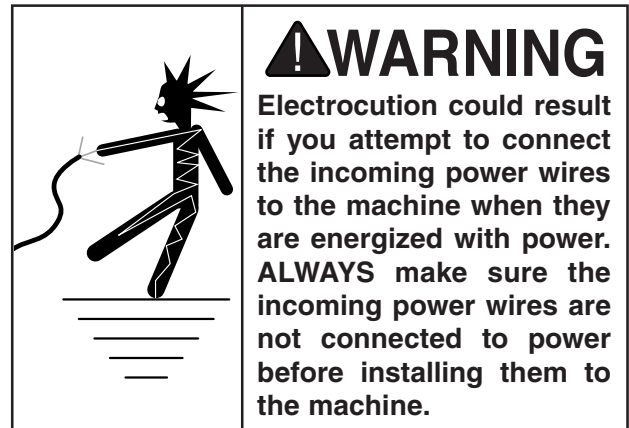

Figure 3. Incoming power electrical box.

3. Pull the power cord through the strain relief on the side of the electrical box and into the electrical box.



4. Connect the incoming ground wire opposite the smaller yellow and green ground wire of the shaper, as illustrated in **Figure 4**.

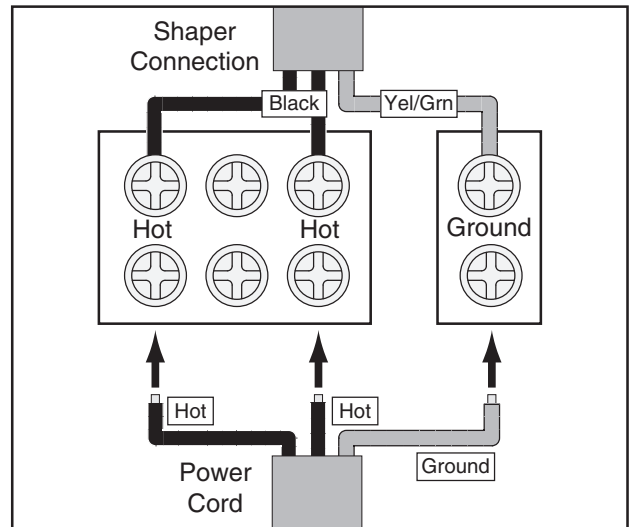
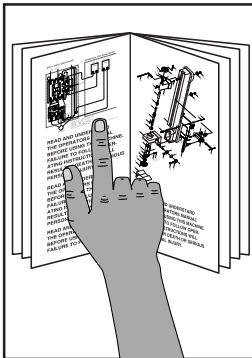

Figure 4. Connecting power cord to electrical box terminal block.

5. Connect the incoming hot wires opposite the two shaper black wires, as illustrated in **Figure 4**.
6. Tighten the strain relief around the incoming power cord, then replace the electrical box cover.



SECTION 3: SETUP



⚠️ WARNING

This machine presents serious injury hazards to untrained users. Read through this entire manual to become familiar with the controls and operations before starting the machine!

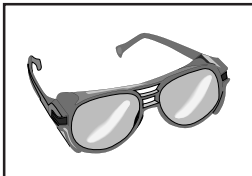

⚠️ WARNING

Wear safety glasses during the entire setup process!

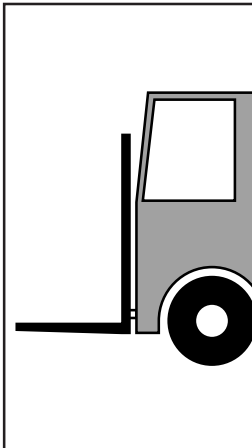

⚠️ WARNING

The Model G9933 is a heavy machine. Serious personal injury may occur if safe moving methods are not used. To be safe, get assistance and use power equipment rated for at least 1500 lbs. to move the shipping crate and remove the machine from the crate.

Needed for Setup

The following are needed to complete the setup process, but are not included with your machine:

| Description | Qty |
|--|--------------|
| • Another Person | At Least 1 |
| • Safety Glasses | 1 Per Person |
| • Lifting Web Straps/Chains (optional) | 3 |
| • Safety Hooks (optional) | 3 |
| • Lifting Chain & Safety Hook (optional) | 1 |
| • Forklift | 1 |
| • Dust Collection System | 1 |
| • 4" Dust Hose & Clamp | 1 Each |

Unpacking

Your machine was carefully packaged for safe transportation. Remove the packaging materials from around your machine and inspect it. If you discover the machine is damaged, *please immediately call Customer Service at (570) 546-9663 for advice.*

Save the containers and all packing materials for possible inspection by the carrier or its agent. *Otherwise, filing a freight claim can be difficult.*

When you are completely satisfied with the condition of your shipment, inventory the contents.



Inventory

The following is a description of the main components shipped with your machine. Lay the components out to inventory them.

Note: *If you can't find an item on this list, check the mounting location on the machine or examine the packaging materials carefully. Occasionally we pre-install certain components for shipping purposes.*

| Inventory: (Figures 5–6) | Qty |
|---|-----|
| A. Model G9933 Shaper | 1 |
| B. Fence & Guard Assemblies | 3 |
| C. Toolbox | 1 |
| D. Dust Hood | 1 |
| E. Miter Gauge..... | 1 |
| F. Spindle Wrench..... | 1 |
| G. Spindle Key | 1 |
| H. Combo Wrenches 11/13, 17/19mm | 1 |
| I. Hex Wrench Set 1.5–10mm..... | 1 |
| J. Hardware Bag | 1 |
| —Hex Bolts M6-1 x 16mm (Dust Hood)..... | 3 |
| —Flat Washers 6mm (Dust Hood) | 3 |
| —Hex Bolts M10-1.5 x 30 (Fence) | 6 |
| —Flat Washers 10mm (Fence) | 6 |

If any nonproprietary parts are missing (e.g. a nut or a washer), we will gladly replace them; or for the sake of expediency, replacements can be obtained at your local hardware store.

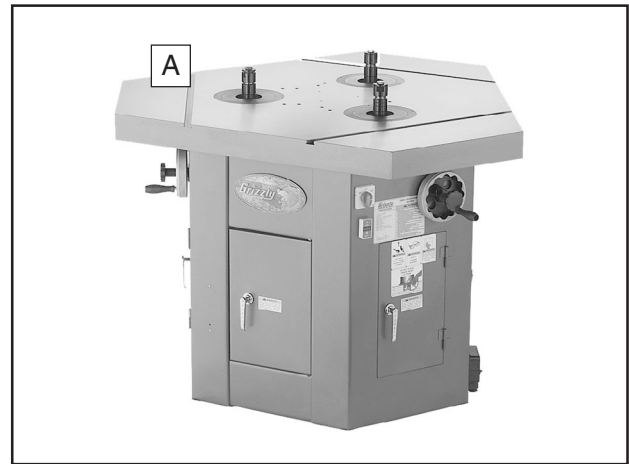

Figure 5. Model G9933 base unit.

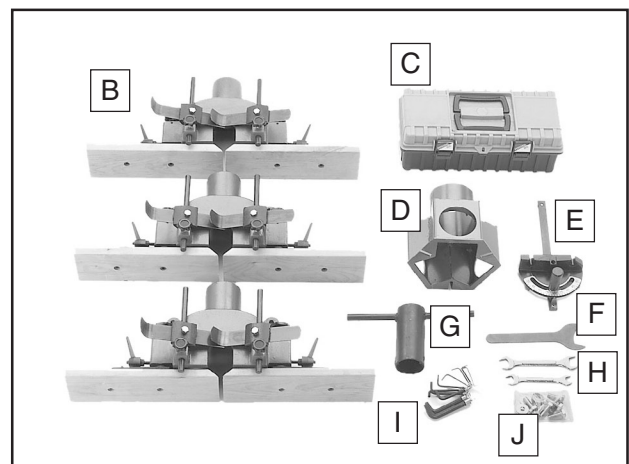

Figure 6. Model G9933 components inventory.



!WARNING

SUFFOCATION HAZARD!

Immediately discard all plastic bags and packing materials to eliminate choking/suffocation hazards for children and animals.



Cleanup

The unpainted surfaces of your machine are coated with a heavy-duty rust preventative that prevents corrosion during shipment and storage.

This rust preventative has been your machine's close ally and guardian since it left the factory. If your machine arrived to you free of rust, then be thankful that the rust preventative protected it during its journey...and try to stay thankful as you clean it off, because it can be challenging to remove if you are unprepared and impatient.

Plan on spending some time cleaning your machine. The time you spend doing this will reward you with smooth sliding parts and a better appreciation for the proper care of your machine's unpainted surfaces.

Although there are many ways to successfully remove the rust preventative, these instructions walk you through what works well for us.

Before cleaning, gather the following:

- Disposable Rags
- Cleaner/degreaser (see below)
- Safety glasses & disposable gloves

H9692—Orange Power Cleaner & Degreaser

One of the best cleaners we've found for quickly and easily removing rust preventative.



Figure 7. Model H9692 Industrial Orange Power Cleaner/Degreaser (99.9% biodegradable).

Note: In a pinch, automotive degreasers, mineral spirits or WD-40 can be used to remove rust preventative. Before using these products, though, test them on an unnoticeable area of your paint to make sure they will not damage it.

Model G9933 (Mfg 1/02+)

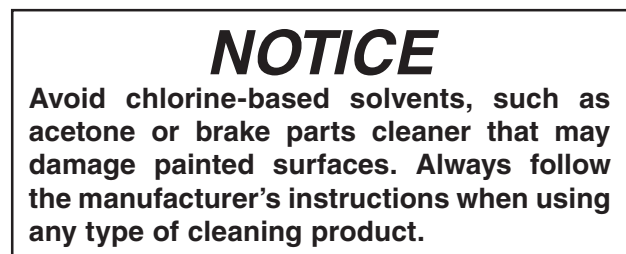
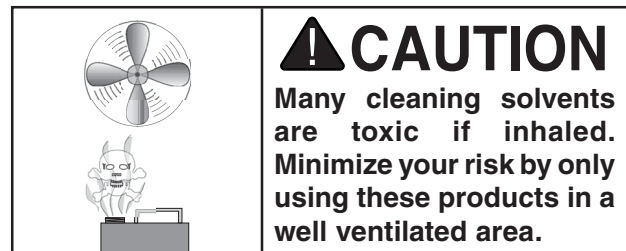
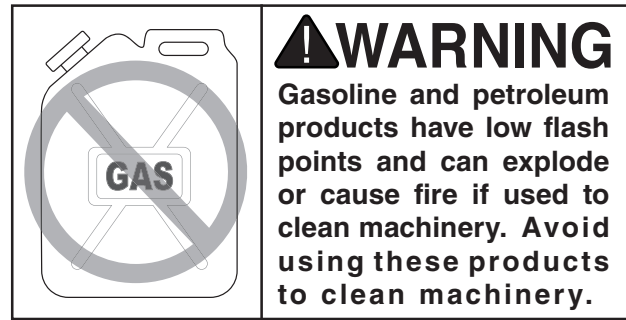

Basic steps for removing rust preventative:

1. Put on safety glasses and disposable gloves.
2. Coat all surfaces that have rust preventative with a liberal amount of your cleaner/degreaser and let them soak for few minutes.
3. Wipe off the surfaces. If your cleaner/degreaser is effective, the rust preventative will wipe off easily.

Note: To clean off thick coats of rust preventative on flat surfaces, such as tables, use a PLASTIC paint scraper to scrape off the majority of the coating before wiping it off with your rag. (Do not use a metal scraper or you may scratch your machine.)

4. Repeat **Steps 2–3** as necessary until clean, then coat all unpainted surfaces with a quality metal protectant to prevent rust.



Site Considerations

Weight Load

Refer to the **Machine Data Sheet** for the weight of your machine. Make sure that the surface upon which the machine is placed will bear the weight of the machine, additional equipment that may be installed on the machine, and the heaviest workpiece that will be used. Additionally, consider the weight of the operator and any dynamic loading that may occur when operating the machine.

Space Allocation

Consider the largest size of workpiece that will be processed through this machine and provide enough space around the machine for adequate operator material handling or the installation of auxiliary equipment. With permanent installations, leave enough space around the machine to open or remove doors/covers as required by the maintenance and service described in this manual. **See below for working clearances.**

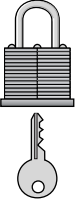
| | |
|---|---|
|  | <p>⚠ CAUTION Children or untrained people may be seriously injured by this machine. Only install in an access restricted location.</p> |
|---|---|

Physical Environment

The physical environment where your machine is operated is important for safe operation and the longevity of its components. For best results, operate this machine in a dry environment that is free from excessive moisture, hazardous chemicals, airborne abrasives, or extreme conditions. Extreme conditions for this type of machinery are generally those where the ambient temperature range exceeds 41°–104°F; the relative humidity range exceeds 20–95% (non-condensing); or the environment is subject to vibration, shocks, or bumps.

Electrical Installation

Place this machine near an existing power source. Make sure all power cords are protected from traffic, material handling, moisture, chemicals, or other hazards. Make sure to leave access to a means of disconnecting the power source or engaging a lockout/tagout device.

Lighting

Lighting around the machine must be adequate enough that operations can be performed safely. Shadows, glare, or strobe effects that may distract or impede the operator must be eliminated.

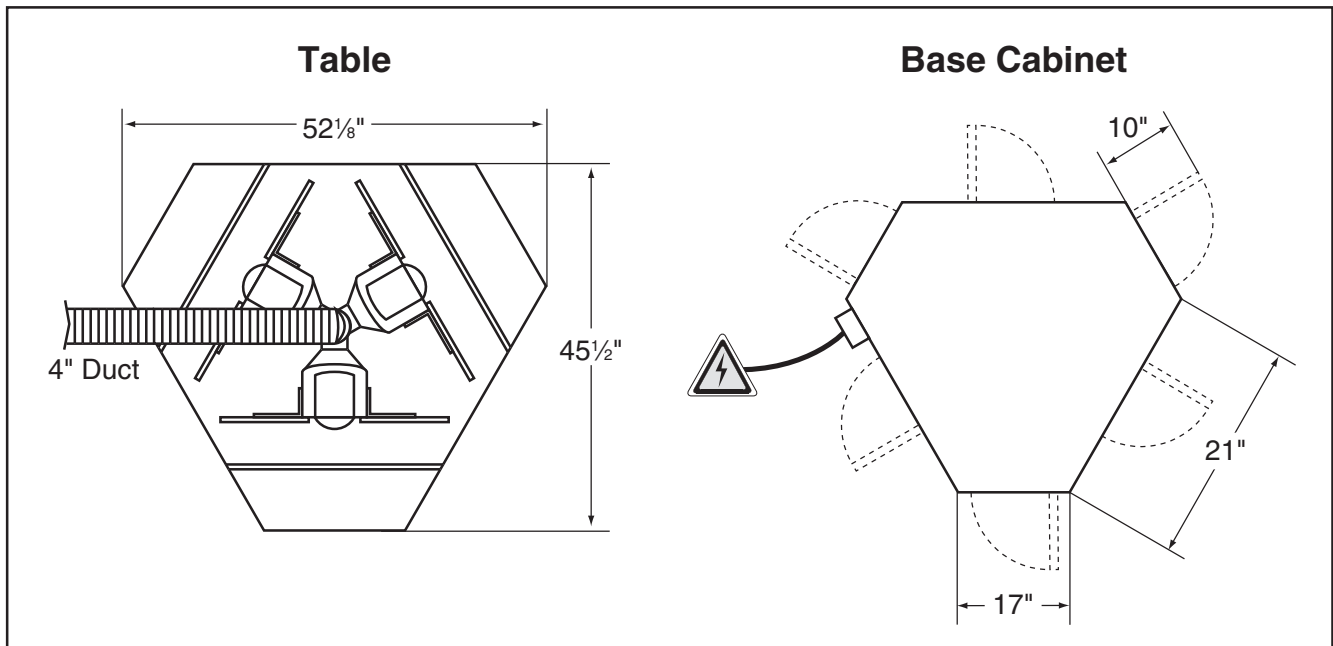
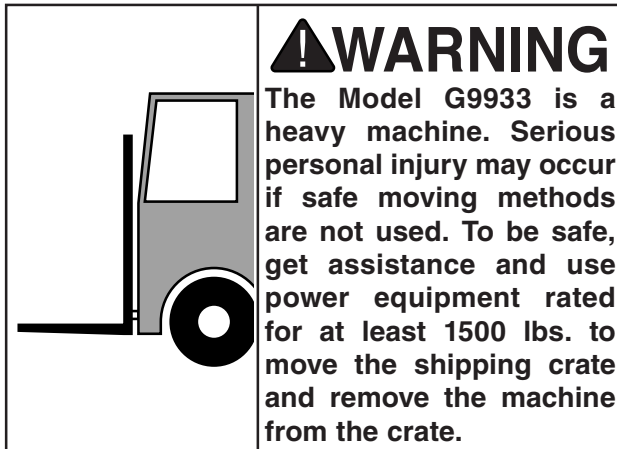

Figure 8. Minimum working clearances.



Lifting & Placing Shaper



The Model G9933 can be lifted with one of the following methods:

- **Lifting Straps & Safety Hooks:** Connect three safety hooks to chains or web straps that are capable of securely hooking underneath the table edge at the three locations shown in **Figure 9**. Then attach the chains or web straps to a center safety chain secured to the power lifting equipment.

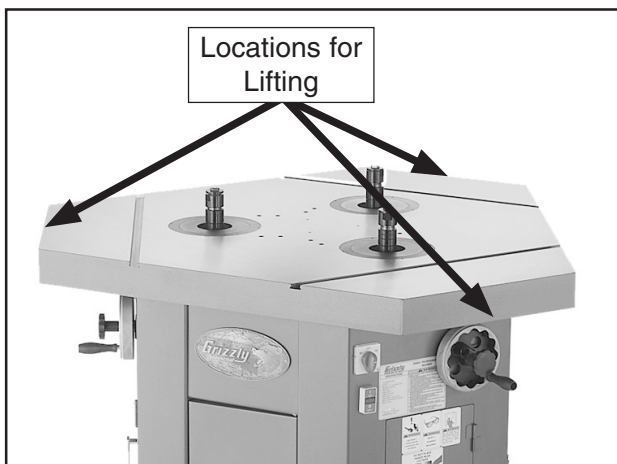

Figure 9. Locations for lifting.

- **Forklift Forks:** Position the forks under the table and close to the cabinet (see **Figure 9**). Use cardboard to protect the table and cabinet from the forks.

Mounting to Shop Floor

Although not required, we recommend that you mount your new machine to the floor. Because this is an optional step and floor materials may vary, floor mounting hardware is not included. Generally, you can either bolt your machine to the floor or mount it on machine mounts. Both options are described below. Whichever option you choose, it is necessary to level your machine with a precision level.

Bolting to Concrete Floors

Anchor studs and lag shield anchors with lag bolts (**Figure 10**) are two popular methods for anchoring an object to a concrete floor. We suggest you research the many options and methods for mounting your machine and choose the best that fits your specific application.

NOTICE

Anchor studs are stronger and more permanent alternatives to lag shield anchors; however, they will stick out of the floor, which may cause a tripping hazard if you decide to move your machine.

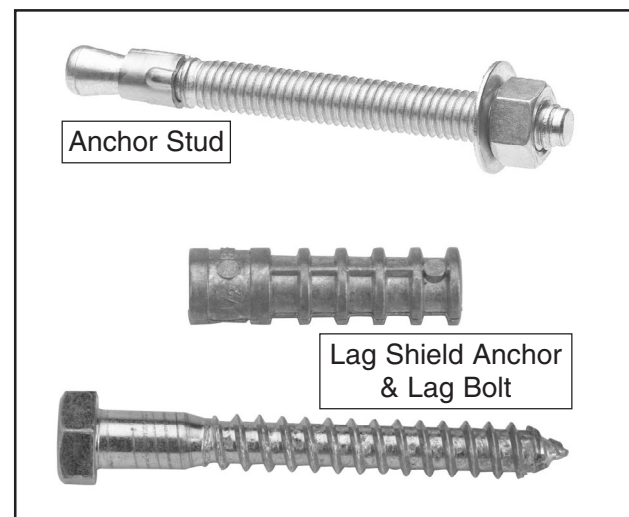

Figure 10. Typical fasteners for mounting to concrete floors.



Using Machine Mounts

Using machine mounts, shown in **Figure 11**, gives the advantage of fast leveling and vibration reduction. The large size of the foot pads distributes the weight of the machine to reduce strain on the floor.



Figure 11. Machine mount example.

Assembly

To assemble your shaper:

1. Align the three holes in the dust hood with their mounting holes in the center of the table, then secure it to the table with the (3) M6-1 x 16 hex bolts and 6mm flat washers (see **Figures 12–13**).

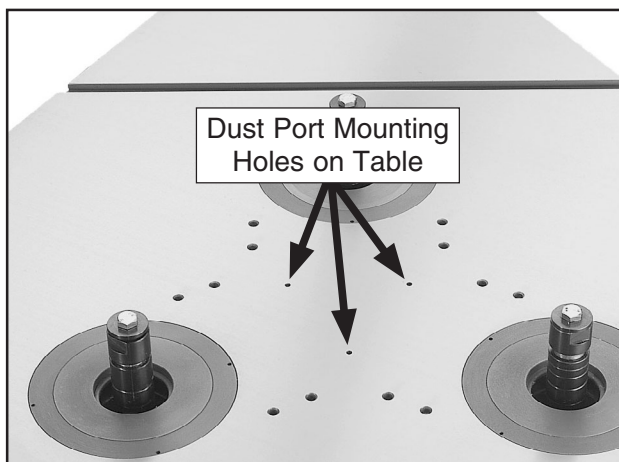

Figure 12. Location of dust hood mounting holes on the table.

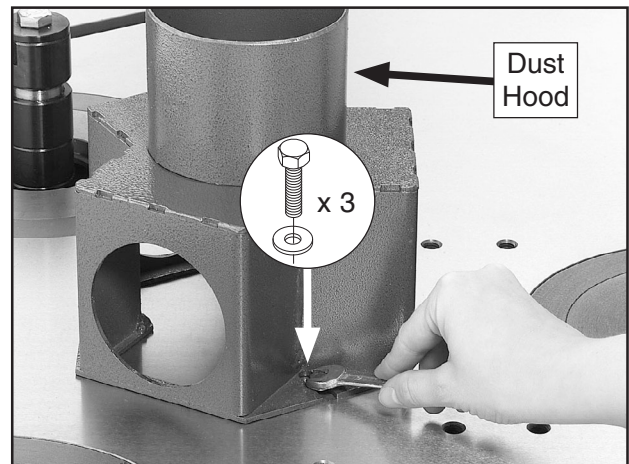

Figure 13. Securing dust hood to the table.

2. Position the fence and guard assemblies so that the guard dust ports are inserted into the dust hood and the mounting slots of the assemblies are aligned with the mounting holes in the table (see **Figures 14–15**).

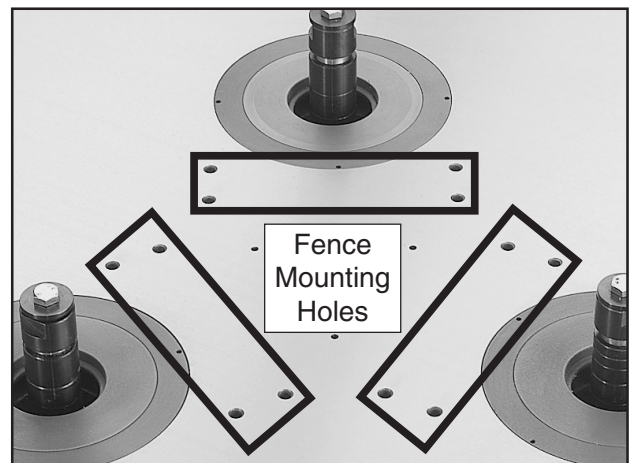

Figure 14. Location of fence assembly mounting holes on the table.

Note: There are two mounting positions for the guard assemblies. Position the assemblies for the best protection from the cutter being used.



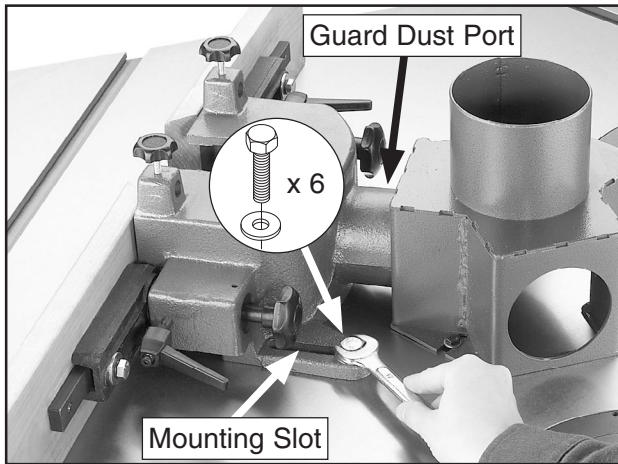

Figure 15. Securing fence assembly and guard to the table.

- Secure the fence and guard assemblies to the table with (6) M10-1.5 x 30 hex bolts and 10mm flat washers, as shown in **Figure 15**.

Dust Collection

⚠ CAUTION

DO NOT operate the Model G9933 without an adequate dust collection system. This shaper creates substantial amounts of wood dust while operating. Failure to use a dust collection system can result in short and long-term respiratory illness.

Recommended CFM at

Each Dust Port:400 CFM

Do not confuse this CFM recommendation with the rating of the dust collector. To determine the CFM at the dust port, you must consider these variables: (1) CFM rating of the dust collector, (2) hose type and length between the dust collector and the machine, (3) number of branches or wyes, and (4) amount of other open lines throughout the system. Explaining how to calculate these variables is beyond the scope of this manual. Consult an expert or purchase a good dust collection "how-to" book.

Connect an adequate dust collection system to the 4" central dust hood. Make sure the dust hose is supported in a vertical position above the shaper table so that it is not in contact with any other part of the shaper and will not interfere with safe working conditions at each station.

Test Run

Once the assembly is complete, test run your machine to make sure it runs properly.

If, during the test run, you cannot easily locate the source of an unusual noise or vibration, stop using the machine immediately, then review the **Troubleshooting** on **Page 39**.

If you still cannot remedy a problem, contact our Tech Support at (570) 546-9663 for assistance.

⚠ WARNING

Before starting the shaper, make sure you have performed the preceding assembly instructions, and you have read through the rest of the manual and are familiar with the various functions and safety features on this machine. Failure to follow this warning could result in serious personal injury or even death!

To test run the machine:

- Make sure all tools and objects used during setup are cleared away from the machine, and that each spindle/cutter can freely rotate without obstruction.
- Make sure all three of the spindle switches are in the STOP position, then connect the machine to power and turn the power ON/OFF switch **ON** to allow power to flow to the motors.

Continued on next page →



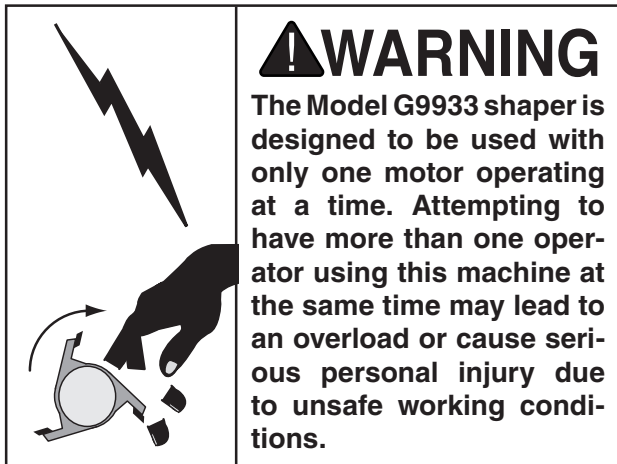

Recommended Adjustments

For your convenience, the adjustments listed below have been performed at the factory and no further setup is required to operate your machine.

However, because of the many variables involved with shipping, we recommend that you at least verify the following adjustments to ensure the best possible results from your new machine.

3. For one station at a time, use the spindle switch to turn each motor **ON**, then listen to and watch for abnormal noises or actions. The machine should run smoothly with little or no vibration or rubbing noises. Turn the motor **OFF**.

—Strange or unusual noises should be investigated and corrected before operating the machine further. Always disconnect the machine from power when investigating or correcting potential problems.

4. Make sure that each spindle rotates in the direction indicated by the spindle switch.

—If a spindle rotates in the opposite direction indicated by the spindle switch, turn the main power switch **OFF**, disconnect the machine from power, then make sure the motor is wired correctly (refer to **Wiring Diagram (A)** on **Page 48**).

—If the motor is wired correctly and the spindle still rotates in the wrong direction, make sure the magnetic switch for that station is wired correctly (refer to **Wiring Diagram (B)** on **Page 49**).

5. Turn the spindle switches to the STOP position, then turn the power switch **OFF**.

Step-by-step instructions for these adjustments can be found on the following referenced pages.

Factory adjustments that should be verified:

- V-belt tension (**Page 38**).
- Table insert adjustment (**Page 41**).
- Fence alignment (**Page 42**).



SECTION 4: OPERATIONS

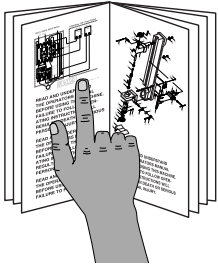

⚠️ WARNING
To reduce the risk of serious injury when using this machine, read and understand this entire manual before beginning any operations.

⚠️ WARNING
Damage to your eyes, lungs, and ears could result from using this machine without proper protective gear. Always wear safety glasses, a respirator, and hearing protection when operating this machine.

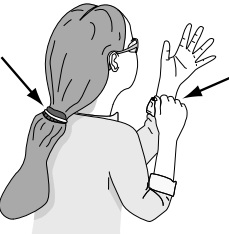
⚠️ WARNING
Loose hair, clothing, or jewelry could get caught in machinery and cause serious personal injury. Keep these items away from moving parts at all times to reduce this risk.

⚠️ CAUTION
No list of safety guidelines can be complete. Every shop environment is different. Always consider safety first, as it applies to your individual working conditions. Use this and other machinery with caution and respect. Failure to do so could result in serious personal injury, damage to equipment, or poor work results.

Power Controls

Power ON/OFF Switch

There is one power ON/OFF switch for the entire machine located on the cabinet (see **Figure 16**). When this switch is turned **ON**, power flows to each of the station spindle switches.

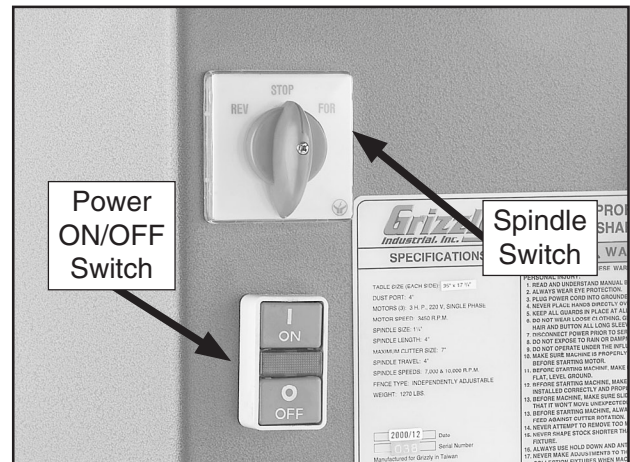

Figure 16. Power ON/OFF switch and spindle switch.

Spindle Switch

Each station of your shaper is equipped with an independent spindle switch (see **Figure 16**) that controls the spindle rotation. When there is power flowing to the machine, the spindle switch is used to select the direction of spindle rotation or to stop the rotation.

NOTICE

If you have never used this type of machine or equipment before, **WE STRONGLY RECOMMEND** that you read books, review industry trade magazines, or get formal training before beginning any projects. Regardless of the content in this section, Grizzly Industrial will not be held liable for accidents caused by lack of training.



Operation Overview

This overview gives you the basic process that happens during an operation with this machine. Familiarize yourself with this process to better understand the remaining parts of the **Operation** section.

To complete a typical operation, the operator does the following:

1. Examines the workpiece to make sure it is suitable for cutting.
2. Installs the cutter onto the spindle and adjusts the spindle height for the operation.
3. Correctly adjusts the fence boards for the operation and locks them in place.
4. Checks the outfeed side of the machine for proper support and to make sure the workpiece can safely move past the cutter without interference from other objects.
5. Places the workpiece on the infeed side of the machine and stabilizes it with hold-downs, jigs, or other safety workpiece holding devices.
6. Wears safety glasses and a respirator, and locates push sticks if needed.
7. Starts the machine.
8. Holds the workpiece firmly and flatly against both the table and fence, and then pushes the workpiece past the cutter at a steady and controlled rate until the workpiece moves completely beyond the cutter.

The operator is very careful to keep the workpiece firmly against the table and fence during the entire cut, while also keeping his hands well away from the spinning cutter.

9. Stops the machine.

Stock Inspection & Requirements

Follow these rules when choosing and cutting stock:

- **Workpiece Material:** Your shaper and cutters are designed to cut wood and wood products ONLY! Do NOT attempt to cut man-made materials (such as glass, metal, plastics, etc.) that may cause the cutter or workpiece to break apart that could cause serious personal injury or property damage.
- **Foreign Objects:** Nails, staples, dirt, rocks and other foreign objects are often embedded in wood. While cutting, these objects can become dislodged and hit the operator, they can cause kickback, and they can break or chip the cutter, which might then fly apart. Always visually inspect your workpiece for these items. If they can't be removed, do NOT cut the workpiece.
- **Large/Loose Knots:** Loose knots can become dislodged during the shaping operation. Large knots can cause kickback and machine damage. Choose workpieces that do not have large/loose knots or plan ahead to avoid cutting through them.
- **Wet or "Green" Stock:** Cutting wood with a moisture content over 20% causes unnecessary wear on the cutter, increases the risk of kickback, and yields poor results.
- **Excessive Warping:** Workpieces with excessive cupping, bowing, or twisting are dangerous to shape because they are unstable and often unpredictable when being cut. DO NOT use workpieces with these characteristics!
- **Minor Warping:** Workpieces with slight cupping can be safely supported if the cupped side is facing the table or the fence. On the contrary, a workpiece supported on the bowed side will rock during the operation and could cause kickback or severe injury.



Cutter Rotation Direction

Most cutters are designed to rotate counter-clockwise and mill the stock from underneath the workpiece which provides a safety barrier between the spinning cutter and the operator. In this case, the workpiece is fed past the cutter from right to left—against the cutter rotation.

⚠️ WARNING

ALWAYS check the direction of the cutter rotation before beginning operation and **ALWAYS** feed the stock into the cutter **AGAINST** the cutter rotation. Feeding stock **WITH** the rotation of the cutter greatly could pull the workpiece from your hands and draw your hands into the spinning cutter, resulting in serious personal injury.

However, some cutters are designed to shape from the top of the workpiece, which exposes the operator to the spinning cutter and increases the risk of operator injury. To avoid this hazard, mount this type of cutter upside down on the spindle, reverse the spindle rotation, then feed the workpiece past the cutter from left to right. Refer to **Cutter Installation** on **Page 25** for detailed instructions.

Cutter Height

The cutter height is adjusted with the height handwheel. One full revolution of the handwheel equals a cutter height change of 1mm.

To gauge the cutter height in relation to the table, use a precision ruler with fine graduations. An alternative method would be to place a sample of the shaped cut next to the cutter.

To change the cutter height:

1. DISCONNECT SHAPER FROM POWER!
2. Loosen the height lock knob and rotate the height handwheel to bring the cutter to the required height, then re-tighten the lock knob (see **Figure 17**).

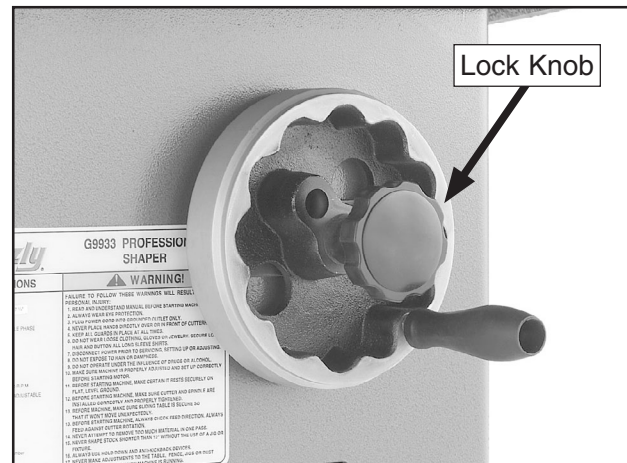

Figure 17. Height handwheel and lock knob.



Hold-Downs

The hold-downs included with your shaper are used to hold the workpiece flat on the table and snug against the fence as it passes the cutter. The position of the hold-down fingers can be adjusted in-or-out or at a different angle with the use of the adjustment knobs and adjustment bolts, as shown in **Figure 18**.

Make sure the curved part of the hold-down finger is pointing in the direction that the workpiece will move past the cutter or it may stop the workpiece during the operation.

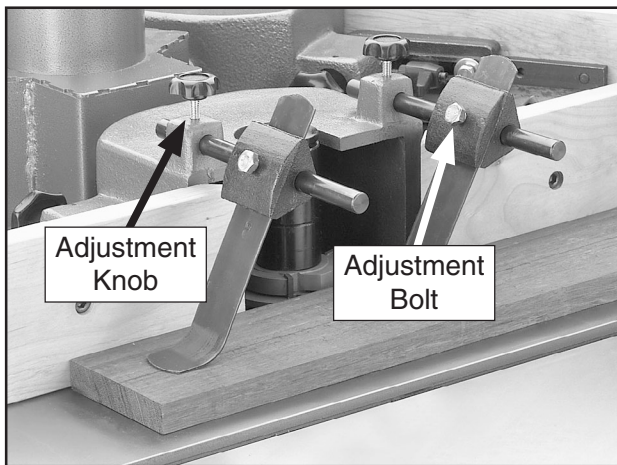

Figure 18. Hold-downs.

⚠️ WARNING

If the workpiece should rise up when it is against the cutter, kickback could occur. To reduce the chance of kickback and serious personal injury, always properly secure the workpiece with the hold-downs during operation.

Fence Adjustment

Your shaper features two-piece adjustable fences. Each fence board can be independently adjusted side-to-side and in-out for different cutting thickness requirements and special shaping applications.

| Tools Needed | Qty |
|-------------------|-----|
| Wrench 13mm | 1 |

Side-To-Side Fence Adjustment

1. DISCONNECT SHAPER FROM POWER!
2. Loosen the side adjustment hex bolt on the back of the fence board shown in **Figure 19**.

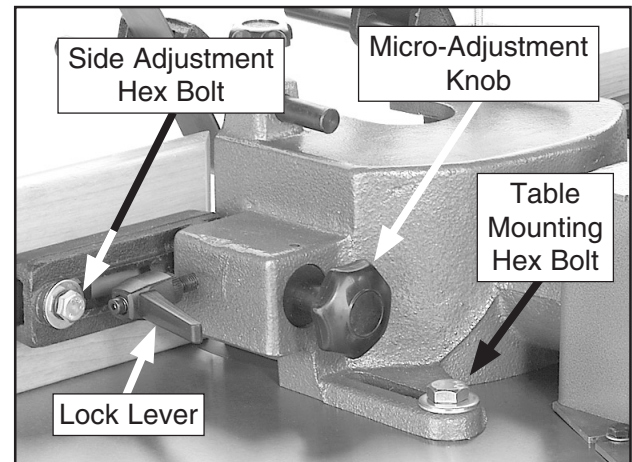

Figure 19. Fence controls.

3. Slide the fence board as close as possible to the cutter without interfering with its rotation, then re-tighten the hex bolt.



⚠ CAUTION

Keep the fence opening around the cutter as small as possible without interfering with the cutter rotation. This configuration provides the best support for the workpiece and reduces operator exposure to the spinning cutter during operation.

In-Out Fence Adjustment

1. DISCONNECT SHAPER FROM POWER!
2. Use the following methods to change the fence board positions in-out relative to the cutter:
 - Loosen the table mounting hex bolts that secure the fence and guard assembly to the table (see **Figure 19**), slide the assembly to the required position, then re-tighten the hex bolts.
 - Remove the table mounting hex bolts, align the mounting slots with the other set of holes in the table, then re-install the hex bolts.
 - Loosen the lock lever (see **Figure 19**), rotate the micro-adjustment knob to move the fence board in-or-out, then re-tighten the lock lever to secure the fence board in position.

Changing Speeds

The cutter speeds for the Model G9933 are 7000 and 10,000 RPM.

Since the cutter is mounted on the spindle, the terms spindle speed and cutter speed are often used interchangeably.

Use the following rules when selecting the speed for your operation:

- Use scrap stock similar to the workpiece to find the right cutter speed and feed rate so that the resulting cut is smooth and requires little sanding to finish.
- Reduce cutter speed or increase feed rate if your workpiece becomes glazed or burned.
- Increase cutter speed or decrease feed rate if your workpiece shows a rough or washboard surface.
- The cutting edges of large cutters travel faster than those of smaller cutters at the same spindle speed, as shown in **Figure 20**. Use the slower speed for large cutters.

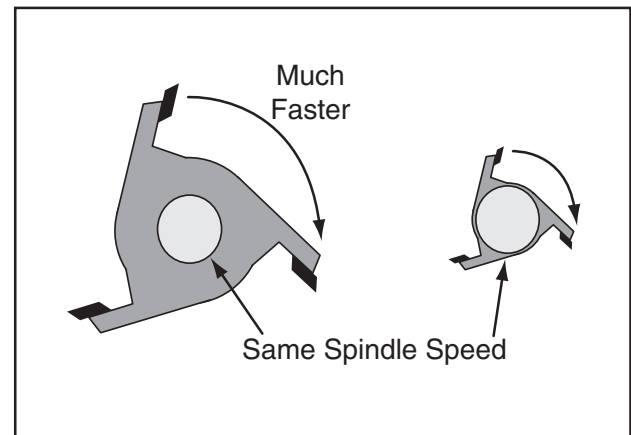

Figure 20. Relative speeds of cutting edges between large and small cutters.



The cutter speed for each motor is changed independently by adjusting the V-belt position on the motor and spindle pulleys, as shown in **Figure 21**.

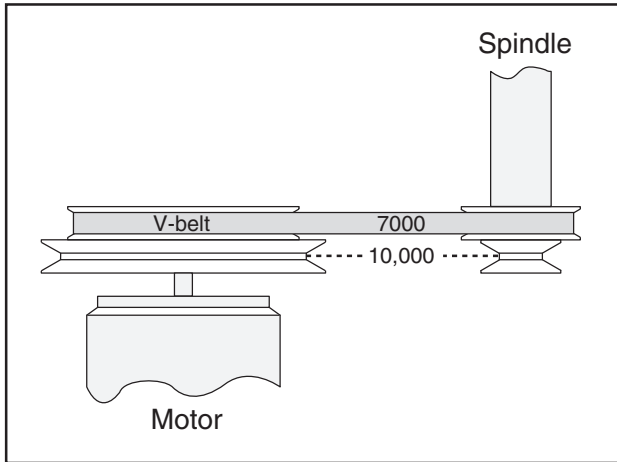
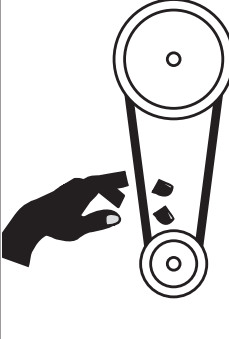

Figure 21. V-belt configurations for the two cutter speeds.



⚠ WARNING
To avoid serious personal injury from entanglement and electrocution hazards, ALWAYS disconnect the machine from power before opening the cabinet doors and ALWAYS close and secure the cabinet doors before re-connecting the machine to power.

To change the cutter speed:

1. DISCONNECT SHAPER FROM POWER!

2. Open the motor access door and loosen the motor lock lever shown in **Figure 22**.

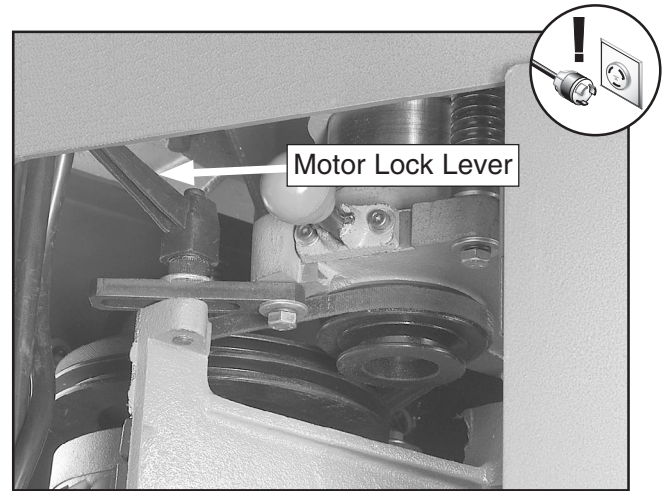

Figure 22. Motor lock lever.

3. Move the motor toward the spindle, then position the V-belt for the correct speed (see **Figure 21**).
4. Push the motor away from the spindle to tension the V-belt, then re-tighten the motor lock lever.

Note: The V-belt is properly tensioned when there is approximately $\frac{1}{4}$ " deflection between the pulleys when moderate pressure is applied, as illustrated in **Figure 23**.

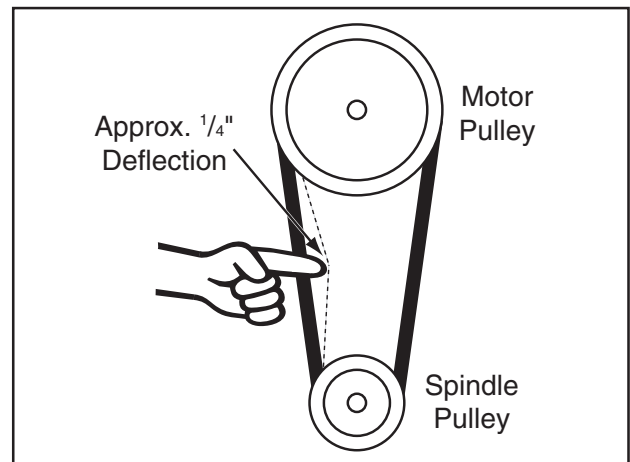

Figure 23. Correct deflection when V-belt is properly tensioned.

5. Close and secure the motor access door before beginning operation.



Table Inserts

Your shaper includes two table inserts with inside openings of 3¼" and 6¼" (see **Figure 24**). The table counterbore with both inserts removed is 8¼" in diameter.

Use the smallest opening that the cutter will allow without interfering with its rotation. This offers more support for the workpiece and reduces the amount of chips that can fall into the machine. Also, make sure the spindle is large enough to allow any unused portion of the cutter to remain below the table surface, which increases operator protection.

If necessary, refer to the **Table Insert Adjustment** subsection on **Page 41** for detailed instructions on leveling the inserts with the table.

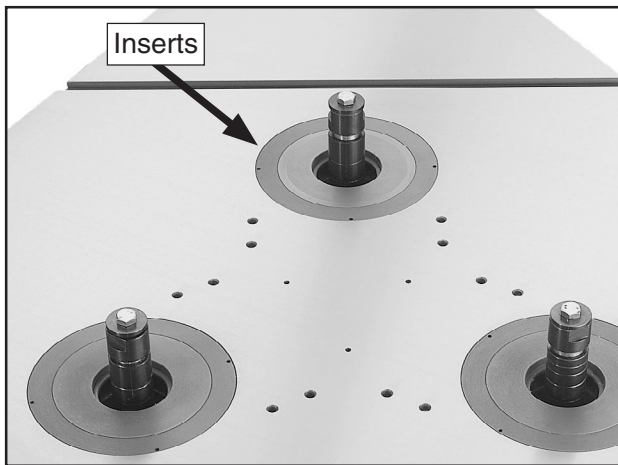

Figure 24. Table inserts (fence and guard assemblies removed for clarity).

Cutter Installation

The spindle that is included with your shaper only accepts cutters with a 1¼" bore.

A ¾" spindle and a ½" router bit spindle are available through Grizzly. Refer to **Accessories** on **Page 34** for spindle options, and **Spindle Replacement** on **Page 41** for detail instructions.

To ensure a safe and efficient operation, follow these rules when installing cutters:

- The cutting edges of large cutters travel faster than smaller ones at the same spindle speed. Cutters with a 3½" or larger outside diameter must be operated at the lower speed of 7000 RPM.
- Wear heavy leather gloves when handling the sharp cutters.
- Keep the spindle, spacers, and cutter clean and free of debris, grease, or oils to avoid binding the spacers or cutter on the spindle.
- Use the smallest table insert possible to keep the space between the table surface and the cutter to a minimum. This will help keep wood chips from falling into the cabinet, provide better workpiece support, and increase operator protection from the cutter.
- If the cutter is designed to remove material from the top of the workpiece, we recommend you mount the cutter upside down, then reverse the spindle rotation and feed direction. In this configuration, the workpiece provides a safety barrier between the cutter and the operator.
- Always use the largest spindle possible.
- Do not attempt to use bushings or devices to install a cutter with a larger bore than the spindle diameter. This could damage the cutter and the machine, and present an injury hazard to the operator.
- Use the spacers to install the cutter as low as possible on the spindle, which will reduce the wear on the spindle bearings and provide a more efficient cutting operation.



Grizzly carries an extensive line of cutters that are designed for use with Grizzly shapers. Refer to our current catalog or website for listings.

Installing Cutter

| Tools Needed | | Qty |
|-----------------------------|--|-----|
| Spindle Wrench | | 1 |
| Wrench or Socket 17mm | | 1 |
| Wrench or Socket 19mm | | 1 |

To install a cutter:

1. DISCONNECT SHAPER FROM POWER!
2. Remove the fence and guard assembly, then raise the spindle all the way up.
3. To keep the spindle from rotating during the following steps, open the cabinet door and pull the spindle lock knob out, then rotate it clockwise until it slips into the deeper of the two detents and the spindle no longer rotates by hand (see **Figure 25**).

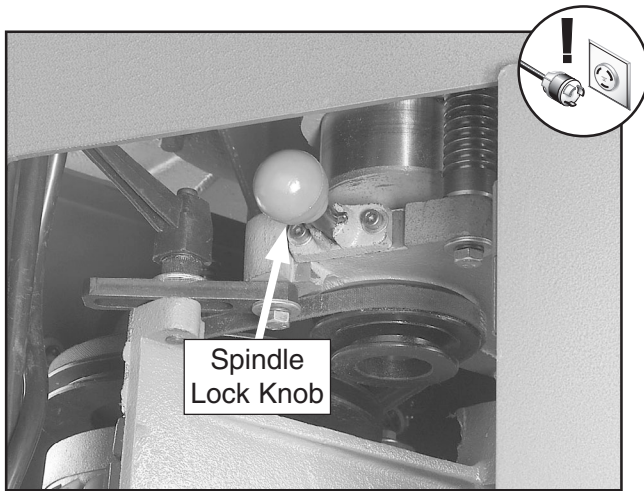

Figure 25. Spindle lock knob.

4. Use the spindle wrench to keep the spindle nut from rotating as you unthread the locking hex bolt and flat washer from the spindle, as shown in **Figure 26**.

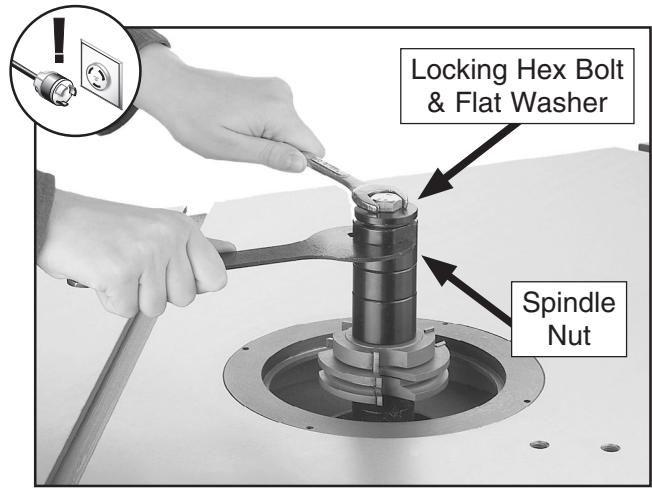

Figure 26. Removing the spindle nut.

5. Remove the spindle nut and the spacers.

Note: The goal in the next steps is to install the cutter and spacers in a configuration that will keep the cutter as low as possible on the spindle. Also, make sure the spindle nut is slightly higher than the spindle when it is fully tightened down so that the locking hex bolt and flat washer can apply locking pressure to the nut and not the spindle, as illustrated in **Figure 27**.

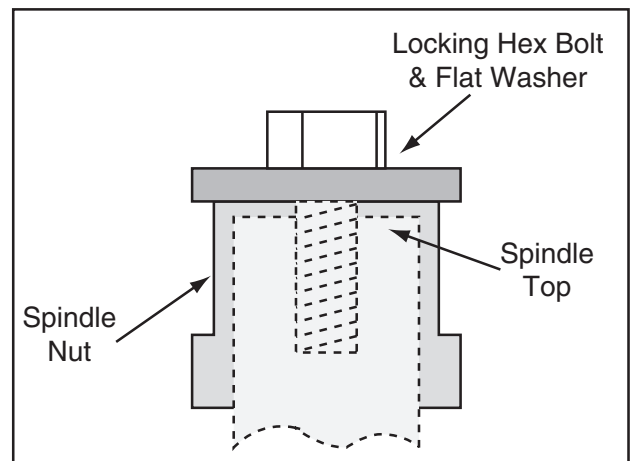
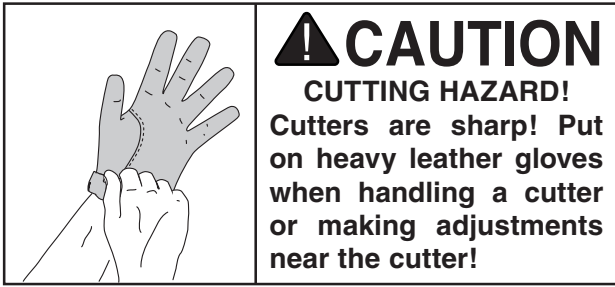

Figure 27. Spindle nut correctly secured by the locking hex bolt and flat washer.





6. Place the cutter and spacers onto the cutter spindle in the proper configuration.
7. Thread the spindle nut onto the cutter spindle and use the spindle wrench to tighten it until it is just snug—do not overtighten.
8. Re-install the locking hex bolt and flat washer onto the cutter spindle and make sure it is applying pressure to the spindle nut, not the spindle top.
9. To release the spindle, reach into the cabinet, pull the spindle lock knob out, then rotate it counterclockwise until it slips into the shallow detent.
10. Close and secure the cabinet door, then properly re-install the fence and guard assembly.

Cutter Safety Guard

Although the fence and guard assembly provides a safety barrier between the cutter and the operator, we recommend that you make a custom box guard for additional protection from the front of the cutter, as explained below. The shop-made box guard is particularly important in high-volume shops.

The thickness of your workpiece will determine the height of the box guard, and you will need to build a separate box guard for each workpiece of a different thickness. A box guard can be used with or without a zero-clearance fence (refer to **Shaping Small Stock** on **Page 29** for detailed instructions on making a zero-clearance fence).

The box guard attaches to the fence boards with screws and should be used with hold-downs to support the workpiece. Construct the box guard so that it extends completely out over the cutter while leaving enough distance between the guard and the table for the workpiece to easily pass by the cutter. See **Figure 28** for an example of a custom box guard.

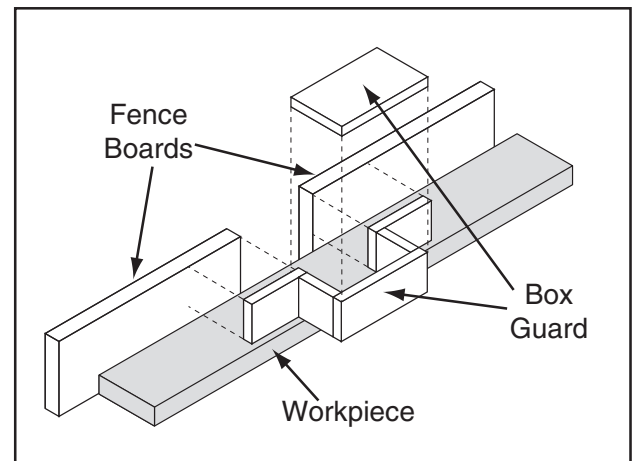

Figure 28. An example of shop-made custom box guard.



Edge Cutting

The fences are a two-piece, independently adjustable system. When removing material from the edge of your workpiece, the outfeed fence can be adjusted to provide support for the workpiece as it passes by the cutter for either full or partial edge cutting.

⚠️ WARNING

Because the fence may not always be perfectly parallel to the table miter slot, using the miter gauge could cause the workpiece to bind and kickback toward the operator. **DO NOT** use the miter gauge to feed the workpiece along the fence when straight shaping. Use a push sticks and hold-downs to keep the workpiece in position.

Full Edge Cutting

1. DISCONNECT SHAPER FROM POWER!
2. Lay a straight piece of stock that is at least 24" in length and the same type of wood and dimensions as the workpiece along the infeed fence board, assuming the feed direction will be from right to left.
3. With the stock held firmly against the infeed fence board, adjust the fence board in-or-out until the stock contacts the cutter for the correct depth of cut, then lock the infeed fence in position.
4. Move the stock away from the cutter, connect the shaper to power, then start the spindle rotating counterclockwise.
5. With the stock firmly held against the infeed fence, safely feed it past the cutter until it reaches the outfeed fence, then stop and pivot the stock away from the cutter.
6. Stop spindle rotation and disconnect the machine from power.
7. When the cutter has come to a complete stop, place the stock against the infeed fence so that one end is in front of the outfeed fence.
8. Adjust and secure the outfeed fence to support the profiled edge of the stock, as illustrated in **Figure 29**.

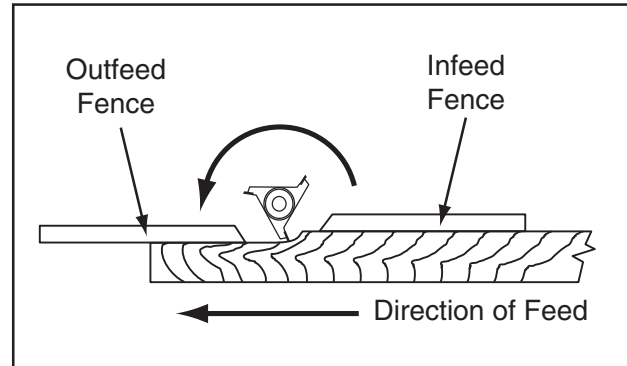

Figure 29. Fence boards properly configured for full face removal.

9. Start the spindle rotating counterclockwise, then feed a test piece past the cutter to verify the cut.

Partial Edge Cutting

1. DISCONNECT SHAPER FROM POWER!
2. Adjust the infeed fence to the desired depth of cut, then lock it in place.
3. Use a straightedge to adjust the outfeed fence even with the infeed fence, then lock it in place.
4. Set both fence boards as close to the cutter from side-to-side as possible without interfering with the cutter rotation. Make sure that the fence boards are firmly secured to the brackets and that all knobs and locks are tight.



5. Start the spindle rotating counterclockwise, then feed a test piece past the cutter to verify the cut, as illustrated in **Figure 30**.

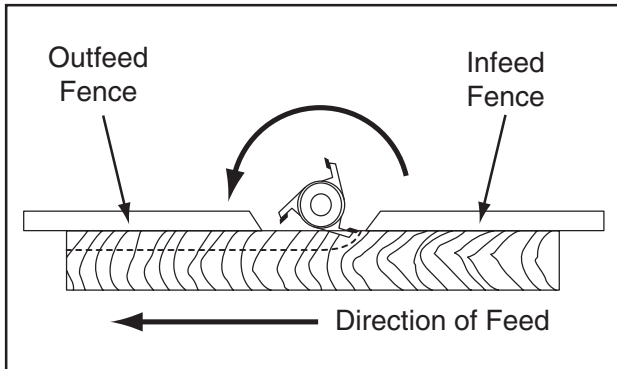

Figure 30. Fence boards adjusted evenly for partial face removal.

Note: To reduce the effects of tearout, cut the end grain first when putting an edge around the perimeter of a workpiece, as illustrated in **Figure 31**.

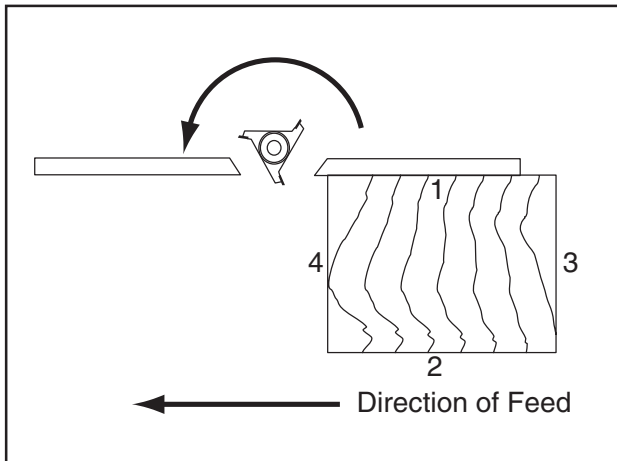

Figure 31. Pattern for cutting end grain first.

⚠️ WARNING

The sound of this shaper when it is running may be less than other devices that are in operation, such as a dust collector. Because of this, it may be difficult to determine if the shaper is running merely by listening. To avoid serious personal injury, you **MUST** make certain the shaper is turned **OFF** and is disconnected from power before attempting any setup or adjustments.

Cutting Rabbets

Your shaper can perform rabbet cuts by using a straight cutter and properly adjusting the spindle height and the fences to produce the desired L-shape cut in the workpiece (see **Figure 32**).

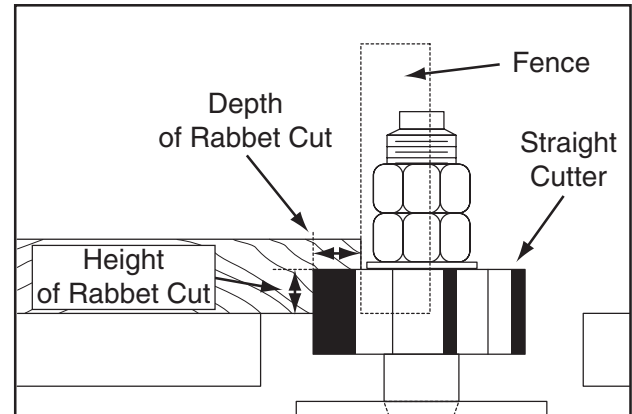

Figure 32. Fence and straight cutter setup for a rabbet cut.

To make a rabbet cut:

1. DISCONNECT SHAPER FROM POWER!
 2. Install a straight cutter and raise it above the table a distance equal to the height of the rabbet cut (see **Figure 32**).
- Note:** To ensure good results for heavy cuts, make multiple light passes and raise the cutter a small amount for each pass.
3. Adjust the fence boards even with one another so that the cutter is exposed to the workpiece by a distance equal to the depth of the rabbet cut (see **Figure 32**).
 4. Turn the machine **ON** and safely feed a test piece past the cutter to verify the rabbet cut.



Shaping Small Stock

Feeding small stock through a shaper is always dangerous. If you must shape small stock, use a zero-clearance fence. This will provide greater protection for the operator, better workpiece support, and reduced tearout on narrow or fragile stock.

⚠ CAUTION

ALWAYS use hold-downs or featherboards and push sticks when shaping small or narrow stock. These devices keep your hands away from the spinning cutter and sufficiently support the stock to allow a safe and effective cut, reducing the risk of personal injury.

To make a zero-clearance fence:

1. DISCONNECT SHAPER FROM POWER!
2. Remove the fence boards from the mounting brackets.
3. Select a piece of straight and smooth stock that is the same height and thickness as the fence boards and approximately 30" long.

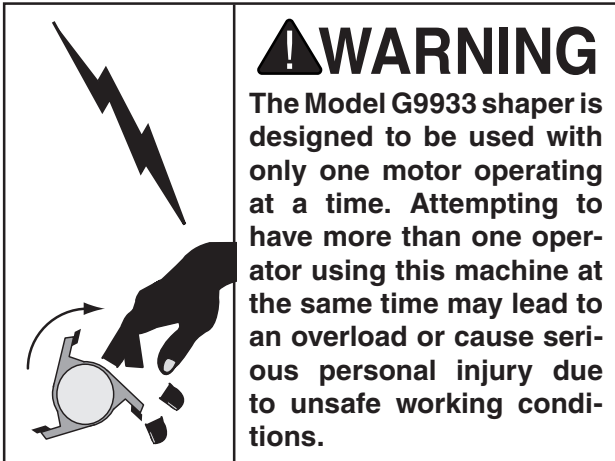

4. Cut an outline of the spindle and cutter from the center of the stock selected in **Step 3**, as illustrated in **Figure 33**.

Note: Make the outline as close as possible to the cutter and spindle without interfering with rotation.

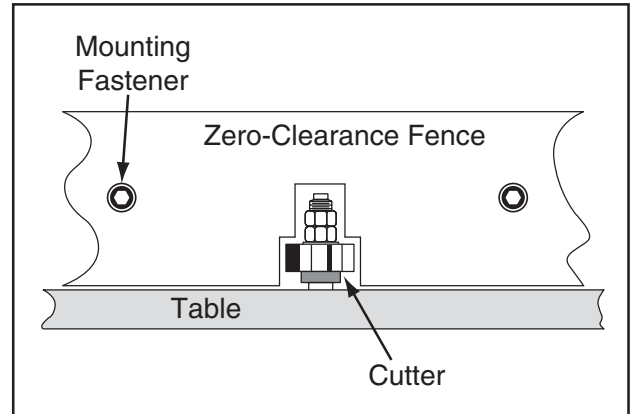

Figure 33. Example of a zero-clearance fence.

5. Create countersunk mounting holes in the zero-clearance fence so that the fasteners from the split fence can be used to secure it to the mounting brackets in the same manner.
6. Secure the zero-clearance fence to the brackets, check for proper clearance, then run a test piece by the cutter to verify the results.



Rub Collars

Rub collars are used when shaping curved or irregular workpieces, such as arched doors or round table tops, and to limit the depth of your cut.

There are two types of rub collars—solid and ball bearing. We recommend using ball bearing collars for smooth operation. Grizzly carries an extensive line of rub collars that are designed for use with Grizzly shapers. Refer to our current catalog or website for listings.

Rub collars are used in one of the following positions:

- **Rub collar below the cutter:** When the rub collar is placed below the cutter, as illustrated in **Figure 34**, the progress of the cut can be observed. However, unintentional movement may lift the workpiece, damaging your work and increasing the risk of injury to the operator. *We DO NOT recommend using the rub collar below the cutter.*

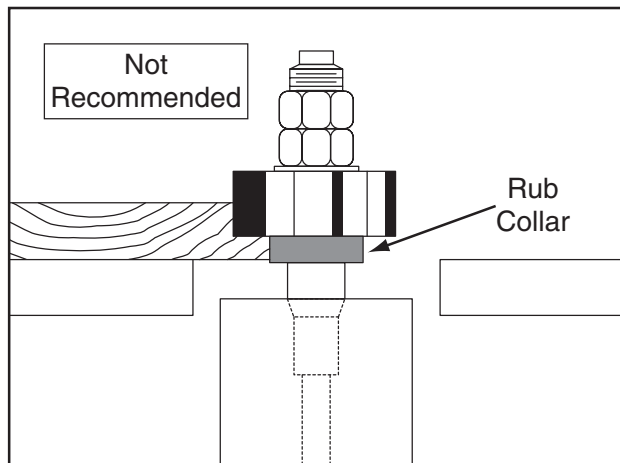

Figure 34. Rub collar installed below the cutter (not recommended).

- **Rub collar above the cutter:** When the rub collar is used above the cutter, the cut cannot be seen, as illustrated in **Figure 35**. This offers the advantage that the cut is not affected by slight variations in thickness, and accidental lifting will not damage the workpiece. Simply correct any variation in height by repeating the cut.

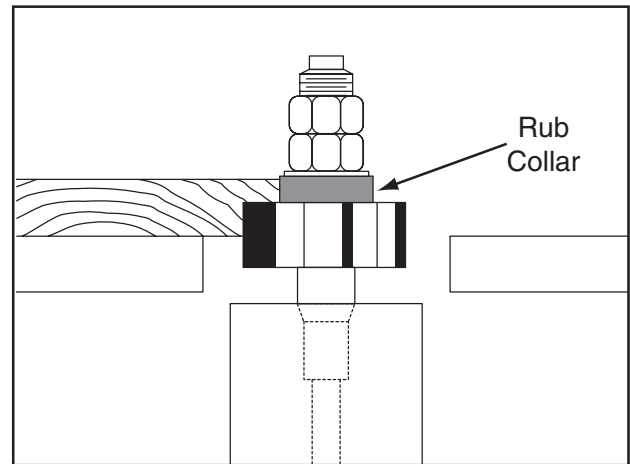

Figure 35. Rub collar installed above the cutter.

- **Rub collar between two cutters:** Using a rub collar between two cutters has the distinct advantage of performing two cuts at once or eliminating the need to change cutters for two different operations, as illustrated in **Figure 36**. Notice the part of the edge that is left uncut rides on the rub collar.

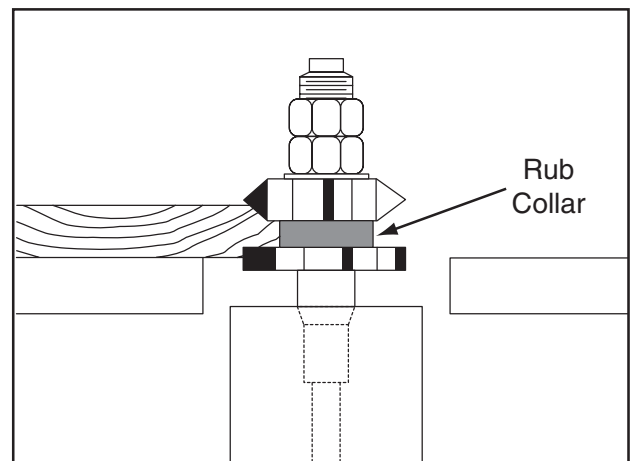

Figure 36. Rub collar installed between two cutters.



Irregular Shaping

| | |
|---|---|
|  | <p>⚠ WARNING</p> <p>Freehand or irregular shaping greatly increases the chance that the operator may lose control of the workpiece, which could result in serious personal injury. Therefore, a pivot point MUST be used to control the workpiece while freehand shaping.</p> |
|---|---|

Irregular or freehand shaping takes a high degree of skill and dexterity. In freehand shaping, the fence and guard assemblies are removed so that a pivot point can be used. The Model G9933 is not designed to be used with a pivot pin. However, a firmly attached board in the proper position can act as a pivot point. Use a jig or fixture to increase the control of the workpiece and protection for the operator. See **Figures 37–38** for examples.

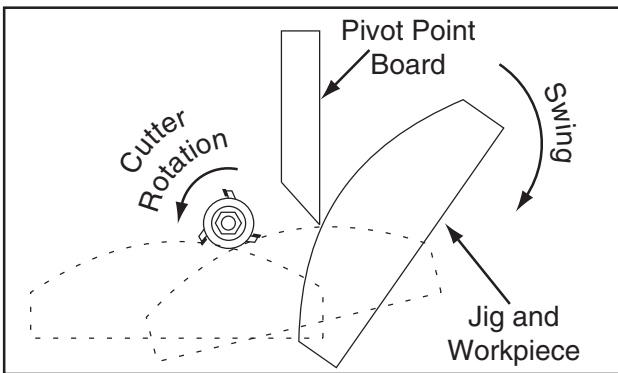

Figure 37. Freehand cutting with a pivot board.

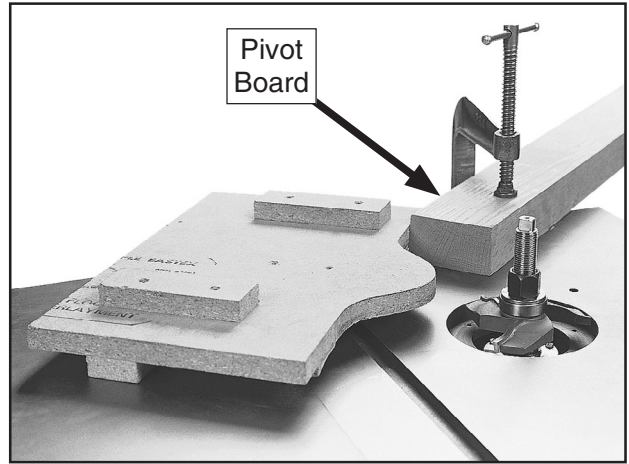

Figure 38. Example of a jig and pivot board.

Pattern Work

When using a pattern, jig, or fixture, use a rub collar to control the depth of cut. Refer to **Rub Collars** on **Page 31** for additional information.

The pattern is typically used when the entire edge is to be shaped or when many duplicate pieces of the same pattern are needed. Pattern work is particularly useful when rough cutting irregular shapes oversize and then freehand shaping the edge in a two-step operation. A pattern can be incorporated into a fixture by adding toggle clamps, hand holds, or other safety devices.

NOTICE

Use care in designing and making fixtures. The workpiece must be firmly secured to the fixture, but the clamps and screws cannot touch the cutter. The workpiece must rest on the shaper table, not on the fixture.



You have greater flexibility when choosing the correct diameter rub collar for pattern work than for non-pattern work. Notice that the position of the pattern in **Figure 39** determines the depth of the cut. Your pattern size is dependent upon the inter-relationship of the cutting circle, the desired amount of material removed, and the rub collar size. The cutting circle is the constant in the equation, while the pattern and the rub collar size are the variables. Changing one or both of these variables will change the amount of material removed. Planning ahead, you can best decide which rub collar is best suited for your application.

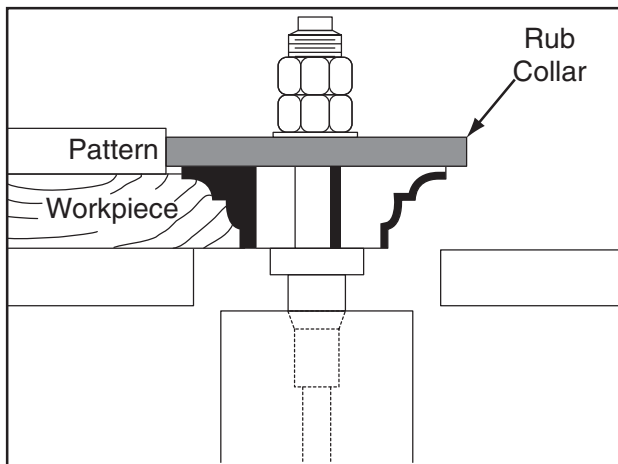

Figure 39. Illustration of pattern work with a rub collar.

When making a pattern, jig, or fixture, follow these guidelines:

- Use a material that will smoothly follow the rub collar or fence.
- Secure your workpiece with toggle clamps on the three sides that will not be cut, or fasten the workpiece to the jig with wood screws.
- Make sure all fasteners and clamping devices do not protrude through the workpiece and will not come in contact with the cutter or table during the operation.
- Make the jig stable by using proven methods and materials, and fasten the hand holds for the operator's comfort and safety.
- Design your fixture so that all cutting occurs underneath the workpiece.
- When calculating the correct depth of cut, always consider the cutting circle and rub collar diameters.
- Make sure the workpiece rests flat on the table and not on the fixture.
- Remember that there is tremendous cutting force exerted on the workpiece. Fixtures must be solid, stable and the workpiece must be firmly secured.



SECTION 5: ACCESSORIES

- G5562—SLIPIT® 1 Qt. Gel
- G5563—SLIPIT® 12 oz Spray
- G2871—Boeshield® T-9 12 oz Spray
- G2870—Boeshield® T-9 4 oz Spray
- H3788—G96® Gun Treatment 12 oz Spray
- H3789—G96® Gun Treatment 4.5 oz Spray



Figure 40. Recommended products for protecting unpainted cast iron/steel part on machinery.

G3030—Shaper Handbook

Roger Cliffe and Michael Holtz show you the potential of your shaper. Hundreds of techniques are explored in vivid detail and clear step-by-step instructions. There are tips on freehand shaping as well as jig and fixture shaping. 256 pages.

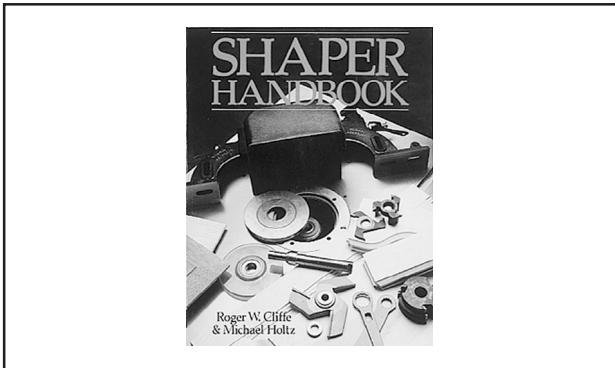

Figure 1. G3030 Shaper Handbook.

- H0783— $\frac{3}{4}$ " Spindle
- H0784— $\frac{1}{2}$ " Router Bit Spindle
- H0785— $\frac{1}{2}$ " Collet for H0784 Router Spindle



Figure 41. Additional spindle options for the Model G9933 Shaper.

G1093—Copy Power Feeder

A powerful model suitable for heavy-duty and mass production applications. Excellent for curve line copying. Features $\frac{1}{2}$ HP, 220V, single-phase motor and 8 feed rates.



Figure 42. G1093 Copy Power Feeder.

Call 1-800-523-4777 To Order



G4179—1/2 HP Power Feeder

Strong enough to handle any job the Model G9933 shaper can. Features 1/2 HP, 220V, single-phase motor with 4 speeds, forward and reverse switch, and three rollers,.



Figure 43. G4179 Power Feeder.

G3642—Shop Fox Right Angle Jig

Whether you are working on a table saw, bandsaw, shaper or sander, the patented Shop Fox Right Angle Jig takes you to a whole new level of safety and accuracy. Crafted from high-density aircraft aluminum, this Right Angle Jig offers a huge advantage when cutting finger joints, tenons, glue joints, or for production jobs. The Right Angle Jig features a powerful toggle clamp for holding workpieces in place, as well as a locking table for multiple cuts and dadoing. The Right Angle Jig can also be used with a wide variety of clamping devices, so you can secure workpieces at nearly any angle. Engineered to fit in standard 3/8" x 3/4" miter slots, the Right Angle Jig offers up to 1 1/2" horizontal and nearly unlimited vertical holding capacity.

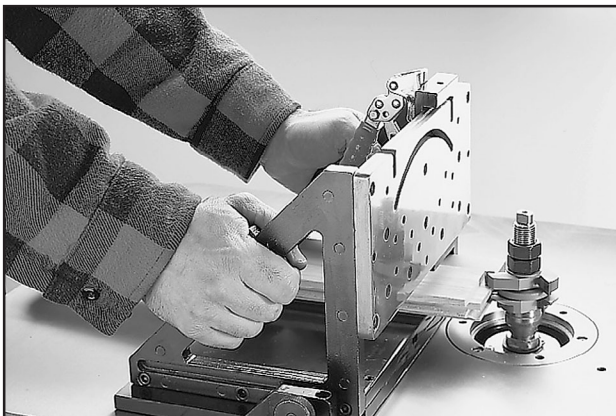

Figure 44. Shop Fox Right Angle Jig.

Grizzly Industrial Spiral Cutterheads

4" Diameter, 1 1/4" Bore

H2875—2" Height

H2876—3 1/8" Height

H2877—4" Height

H2878—5 1/8" Height

H2880—5 7/8" Height

H2880—Carbide Insert

Spiral cutterheads reduce tearout and leave a finish that is second to none. Our Spiral Cutterheads have 9 spirals which result in an incredible finish! The indexable inserts have four cutting sides so the edges can be rotated to expose a new cutting edge when dull or chipped, resulting in very little down time and huge savings over conventional carbide cutters. The solid carbide inserts we use are extra thick and heavy-duty.

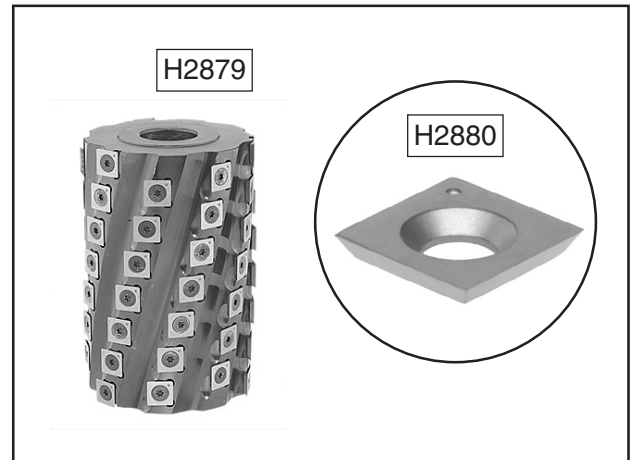

Figure 45. Grizzly Industrial Spiral Cutterhead and Carbide Insert.

G2371—Board Buddies® For Shapers

These green wheels were developed especially for shapers. The main difference between these and the conventional yellow wheels is that these roll in either direction and are used to hold the workpiece down and tightly against the fence.

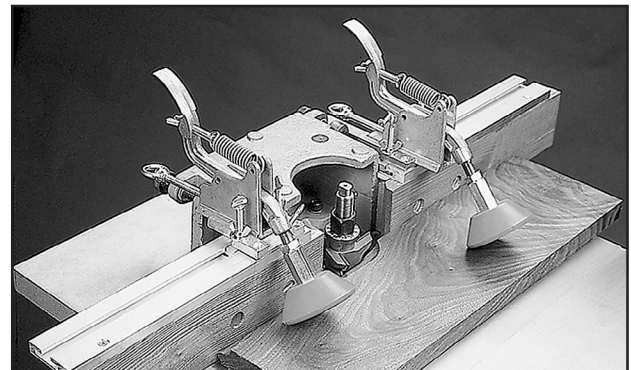

Figure 46. Board Buddies® For Shapers



SECTION 6: MAINTENANCE



Schedule

For optimum performance from your machine, follow this maintenance schedule and refer to any specific instructions given in this section.

Note: *This maintenance schedule is based on average daily usage. Adjust the maintenance schedule to match your usage to keep your shaper running smoothly and to protect your investment.*

Daily:

- Clean and protect the top surfaces.
- Check/tighten loose mounting bolts.
- Check/replace damaged or worn cutters.
- Check/repair worn or damaged wires.
- Check/resolve any other unsafe condition.

Weekly:

- Clean inside of the cabinet.
- Check V-belt condition and tension (**Page 38**).
- Lubricate height worm gear and spindle housing (**Page 37**).

Cleaning & Protecting

Cleaning the Model G9933 is relatively easy. Vacuum wood chips and sawdust from the top surfaces, underneath the table inserts, and inside the cabinet, then wipe off the remaining dust with a dry cloth. If any resin has built up, use a resin dissolving cleaner to remove it.

Protect the unpainted cast iron surfaces on the table by wiping the table clean after every use—this ensures moisture from wood dust does not remain on bare metal surfaces. Then, to keep them rust free, apply a product like G96® Gun Treatment, SLIPIT®, or Boeshield® T-9 (see **Section 5: Accessories on Page 34** for more details).



Lubrication

Worm Gear

Fully lower the spindle, then use shop rags and mineral spirits to clean the worm gear, as shown in **Figure 47**. When dry, apply a small amount of multi-purpose grease to the worm gear, then raise and lower the spindle a few times to distribute the lubricant.

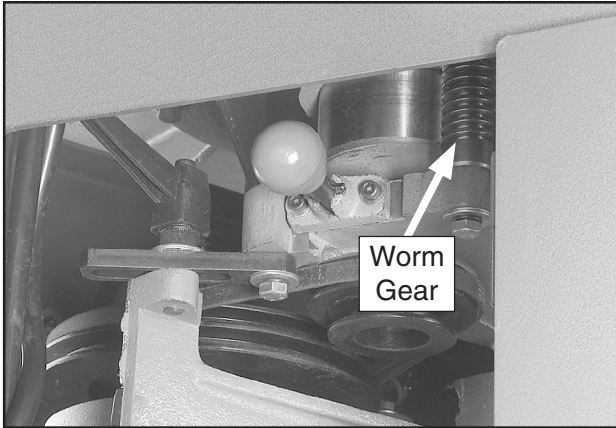

Figure 47. Height worm gear and inside spindle housing.

Spindle Housing

There is a grease cup on the outside of the spindle housing above the motor, as illustrated in **Figure 48**. Unscrew the cup to fill it with multi-purpose grease, then thread it back onto the grease port until you feel the resistance. The pressure from the cup moves the grease onto the surfaces of the outer and inner spindle housing as they move up and down.

Weekly, continue to tighten the grease cup until it no longer holds lubricant, then refill it as described above.

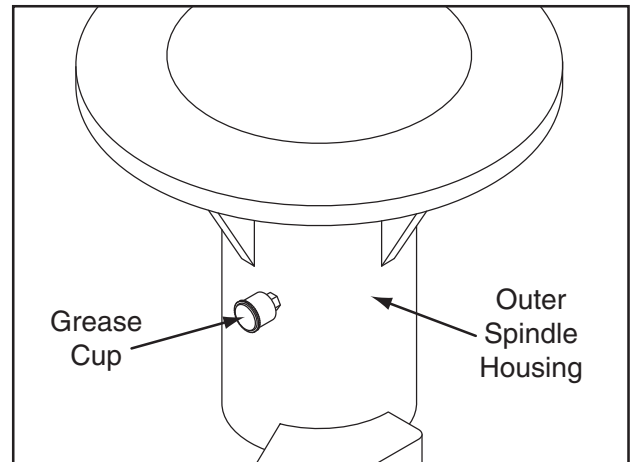

Figure 48. Spindle housing grease cup.



V-Belt Tensioning & Replacement

It is critical that the V-belts are in good working condition and properly tensioned to ensure smooth and efficient operation. If the V-belts show excessive wear, cracks, or any other damage, replace them.

Tensioning V-Belt

1. DISCONNECT SHAPER FROM POWER!
2. Open the motor access door and loosen the motor lock lever shown in **Figure 49**.

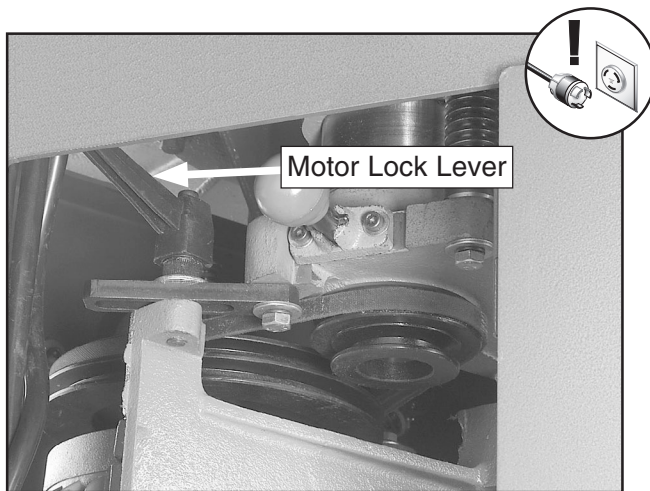

Figure 49. Motor lock lever.

3. Push the motor away from the spindle to tension the V-belt, then re-tighten the motor lock lever.

Note: The V-belt is properly tensioned when there is approximately $\frac{1}{4}$ " deflection between the pulleys when moderate pressure is applied, as illustrated in **Figure 50**.

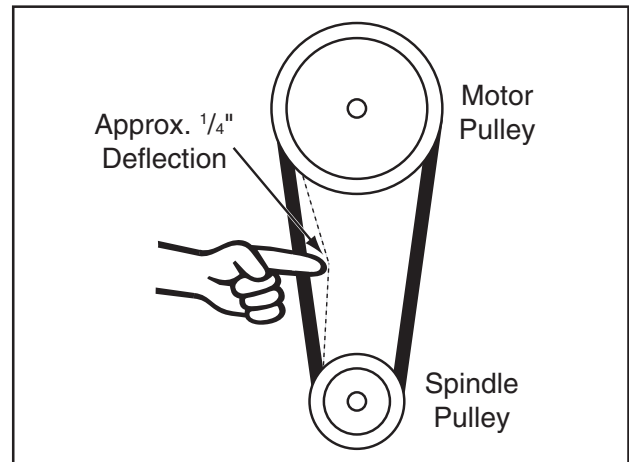

Figure 50. Correct deflection when V-belt is properly tensioned.

Replacing V-Belt

1. Perform **Steps 1–2** in the above procedure, then slip the V-belt off the spindle pulley, over the top of the motor pulley, and pull it out of the cabinet.
2. Replace the V-belt with a new one, properly tension it, as instructed above, then close and secure the motor access door.



SECTION 7: SERVICE

Review the troubleshooting and procedures in this section to fix or adjust your machine if a problem develops. If you need replacement parts or you are unsure of your repair skills, then feel free to call our Technical Support at (570) 546-9663.

Troubleshooting



Motor & Electrical

| Symptom | Possible Cause | Possible Solution |
|--|---|--|
| Machine does not start or a breaker trips. | <ol style="list-style-type: none"> 1. Power supply switched OFF or at fault. 2. Plug/receptacle at fault/wired wrong. 3. Motor connection wired wrong. 4. Thermal overload relay has tripped. 5. Wall circuit breaker tripped. 6. Contactor not energized/has poor contacts. 7. Wiring open/has high resistance. 8. Start capacitor at fault. 9. Main power ON/OFF switch at fault. 10. Spindle rotation switch at fault. 11. Motor at fault. | <ol style="list-style-type: none"> 1. Ensure power supply is ON/has correct voltage. 2. Test for good contacts; correct the wiring. 3. Correct motor wiring connections (Page 48). 4. Reset; adjust trip load dial if necessary; replace. 5. Ensure circuit size is correct/replace weak breaker. 6. Test all legs for power/replace if faulty. 7. Check/fix broken, disconnected, or corroded wires. 8. Test/replace if faulty. 9. Replace switch. 10. Test/replace switch. 11. Test/repair/replace. |
| Machine stalls or is underpowered. | <ol style="list-style-type: none"> 1. Workpiece material not suitable for machine. 2. Fence/jig loose or misaligned. 3. V-belt slipping. 4. Motor wired incorrectly. 5. Plug/receptacle at fault. 6. Pulley slipping on shaft. 7. Motor bearings at fault. 8. Machine undersized for task. 9. Motor overheated. 10. Spindle rotation switch at fault. 11. Motor at fault. | <ol style="list-style-type: none"> 1. Only cut wood/ensure moisture is below 20%. 2. Adjust fence/jig. 3. Tension/replace V-belt (Page 38). 4. Wire motor correctly (Page 48). 5. Test for good contacts/correct wiring. 6. Replace loose pulley/shaft. 7. Test/repair/replace. 8. Use correct, sharp cutter; reduce feed rate/depth of cut. 9. Clean motor, let cool, and reduce workload. 10. Test/replace switch. 11. Test/repair/replace. |
| Machine has vibration or noisy operation. | <ol style="list-style-type: none"> 1. Motor or component loose. 2. Cutter at fault. 3. V-belt worn or loose. 4. Shaper bit or spindle at fault. 5. Pulley loose. 6. Motor mount loose/broken. 7. Machine incorrectly mounted. 8. Motor fan rubbing on fan cover. 9. Motor bearings at fault. | <ol style="list-style-type: none"> 1. Inspect/replace damaged bolts/nuts, and re-tighten. 2. Replace damaged cutter. 3. Tension/replace V-belt (Page 38). 4. Replace cutter; tighten loose spindle; replace defective spindle or spindle cartridge. 5. Realign/replace shaft, pulley, set screw, and key. 6. Tighten/replace. 7. Tighten mounting bolts; relocate/shim machine. 8. Fix/replace fan cover; replace loose/damaged fan. 9. Test by rotating shaft; rotational grinding/loose shaft requires bearing replacement. |





Shaper Operations

| Symptom | Possible Cause | Possible Solution |
|---|---|--|
| Spindle does not raise or lower easily. | 1. Height worm gear is clogged with sawdust. | 1. Clean the height worm gear and inner spindle housing, then lubricate them (refer to Page 37). |
| Workpiece is burned when cut. | <ol style="list-style-type: none"> 1. Dull cutter. 2. Too slow of a feed rate. 3. Pitch build-up on cutter. 4. Cutter rotating in the wrong direction. 5. Taking too deep of a cut. | <ol style="list-style-type: none"> 1. Replace cutter or have it professionally sharpened. 2. Increase feed speed. 3. Clean cutter with a blade and bit cleaning solution. 4. Reverse the direction of the cutter rotation. 5. Make several passes of light cuts. |
| Fuzzy grain. | <ol style="list-style-type: none"> 1. Wood may have high moisture content or surface wetness. 2. Dull cutter. | <ol style="list-style-type: none"> 1. Check moisture content and allow to dry if moisture is more than 20%. 2. Replace or have cutter professionally sharpened. |
| Chipping. | <ol style="list-style-type: none"> 1. Knots or conflicting grain direction in wood. 2. Nicked or chipped cutter. 3. Feeding workpiece too fast. 4. Taking too deep of a cut. 5. Cutting against the grain of the wood. | <ol style="list-style-type: none"> 1. Inspect workpiece for knots and grain direction; only use clean stock. 2. Replace the cutter, or have it professionally sharpened. 3. Slow down the feed rate. 4. Take a smaller depth of cut. (Always reduce cutting depth when working with hard woods.) 5. Cut with the grain of the wood. |
| Divots in the edge of the cut. | <ol style="list-style-type: none"> 1. Inconsistent feed speed. 2. Inconsistent pressure against the fence and rub collar. 3. Fence not adjusted correctly. | <ol style="list-style-type: none"> 1. Move smoothly or use a power feeder. 2. Apply constant pressure. 3. Adjust fence. |



Table Insert Adjustment

The table inserts must be flush with the table around the entire perimeter to prevent the workpiece from catching during operation, which would increase the risk of kickback or produce poor cutting results.

The inner insert depends upon the level of the outer insert to be flush with the table.

| Tools Needed | Qty |
|-----------------------------|-----|
| Wrench or Socket 17mm | 1 |
| Straightedge 12" | 1 |
| Hex Wrench 2.5mm..... | 1 |

To adjust the outer insert:

1. DISCONNECT SHAPER FROM POWER!
2. Remove the fence and guard assembly and the cutter, if installed.
3. Remove both inserts, then use shop rags and mineral spirits to clean the edges of the inserts and the table indent.
4. Replace the inserts into the table, then place the straightedge across the table and the inserts, as shown in **Figure 51**.

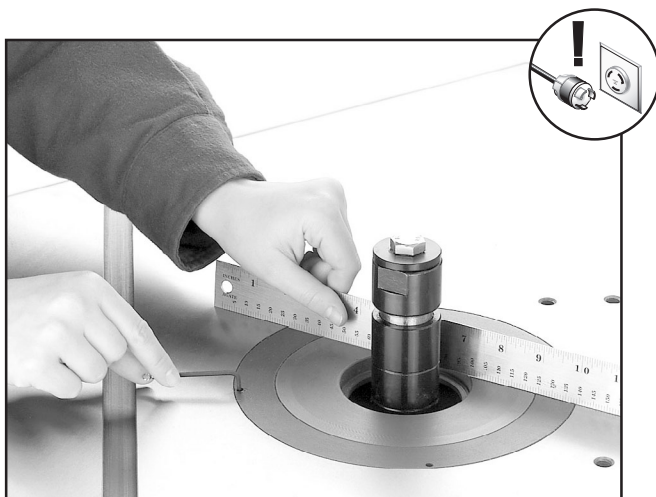

Figure 51. Adjusting the table insert.

5. Adjust the four set screws in the outer insert until the entire surface of the inserts is flush with the table.

Note: Move the straightedge 360° around the spindle to ensure the entire insert surface is flush with the table in all directions.

Spindle Replacement

The Model G9933 will accept different spindles to accommodate a wide variety of cutters. Always use the correct spindle for the cutter being used to ensure a safe and efficient cutting operation.

| Tools Needed | Qty |
|-------------------|-----|
| Spindle Key | 1 |

To replace the spindle:

1. DISCONNECT SHAPER FROM POWER!
2. Remove the fence and guard assembly and the cutter, then raise the spindle all the way up.
3. To keep the spindle from rotating during the following steps, open the cabinet door and pull the spindle lock knob out, then rotate it clockwise until it slips into the deeper of the two detents and the spindle no longer rotates by hand(see **Figure 52**).

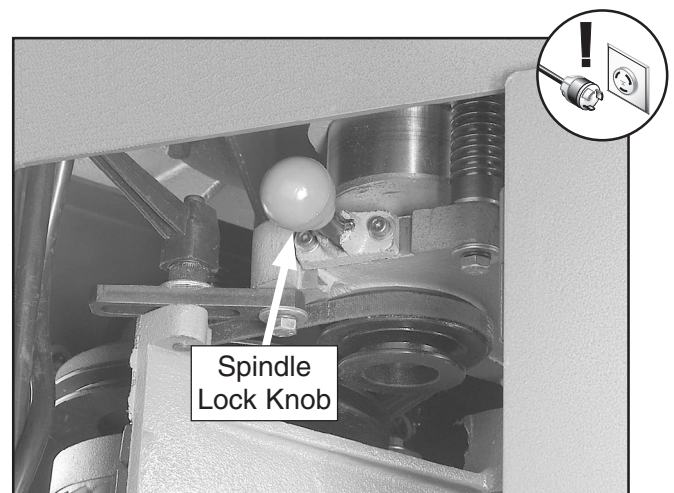

Figure 52. Spindle lock knob.



- Place the spindle key over the spindle and down inside the spindle housing, as shown in **Figure 53**.

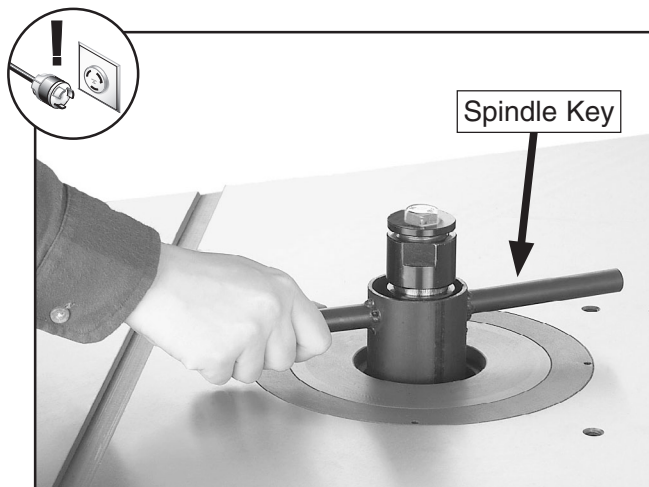

Figure 53 . Loosening the spindle.

- Slowly rotate the spindle key until you feel it lock into place, then turn it counterclockwise to remove the spindle.
- Start the threading of the new spindle into the spindle cartridge by hand, then tighten it with the spindle key until it is snug.
- Release the spindle lock, close the motor access door, and re-install the fence and guard assembly.

Aligning Fence

To ensure safe and accurate cuts, the two sides of the split fence must be aligned in the same plane as one another and parallel with the table miter slot, as illustrated in **Figure 54**.

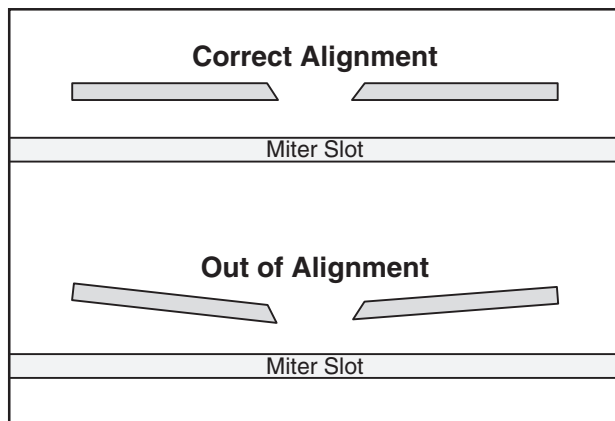

Figure 54. Fence alignment.

| Tools Needed | Qty |
|------------------------|-----------|
| Straightedge 36" | 1 |
| Precision Square | 1 |
| Shimming Material..... | As Needed |

To align the fences in the same plane:

- DISCONNECT SHAPER FROM POWER!**
- Move the fence and guard assembly forward so that you can position a straightedge along both fence sides, as shown in **Figure 55**, and note any part of either fence board that is not up against the straightedge.

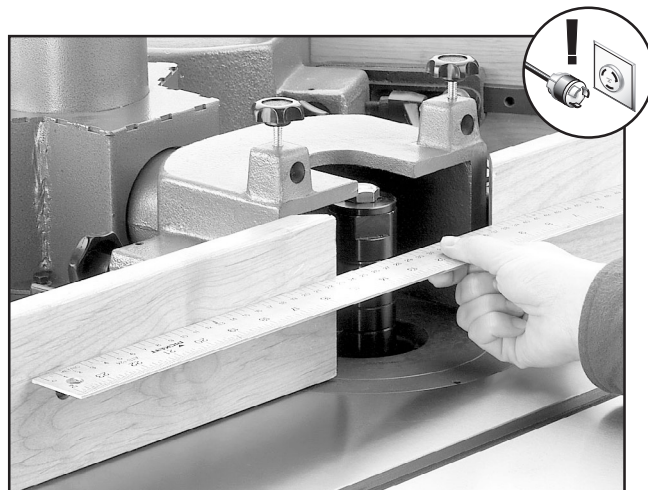

Figure 55. Checking fence alignment.



3. Insert the miter gauge into the miter slot, adjust it to 0°, then place the precision square against the miter gauge and the fence, as shown in **Figure 56**. Note any gaps between the square and the fence.

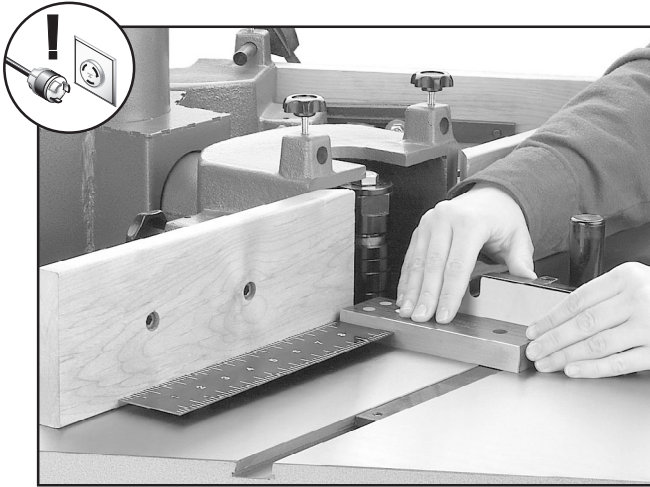

Figure 56. Using the miter gauge and square to check the fence.

4. Make corrections by shimming between the fence boards and the mounting brackets (see **Figure 57**).

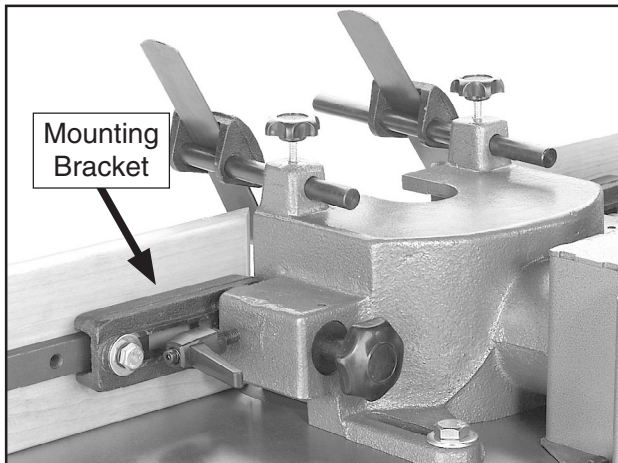

Figure 57. Fence mounting bracket.

5. Repeat **Steps 2–4** until the fence boards are even and in the same plane with one another, and they are parallel to the table miter slot.

Spindle Cartridge/ Bearing Replacement

The cutter spindle attaches to the spindle cartridge, which rotates on bearings within the spindle housing.

If it becomes necessary to replace the spindle cartridge or the spindle bearings, follow the procedure below to accomplish to make these replacements. Read and understand the entire procedure before beginning the process.

| Tools Needed | Qty |
|---|--------------|
| Safety Glasses | 1 Per Person |
| Brass Drift or Small Piece of Wood..... | 1 |
| Hammer..... | 1 |
| Dead Blow Hammer | 1 |
| Internal Retaining-Ring Pliers..... | 1 |
| Hex Wrench 5mm..... | 1 |
| 2x4 Approximately 23" in Length..... | 1 |
| 2x6's Approximately 12" in Length | 2 |

To replace the spindle cartridge or bearings:

1. DISCONNECT SHAPER FROM POWER!
2. Remove the fence and guard assembly.
3. Remove the cutter and cutter spindle.
4. Remove the table inserts.

Continued on next page →



5. Use the brass drift or a piece of wood and a hammer to loosen and remove the spindle housing cover, as shown in **Figure 58**.

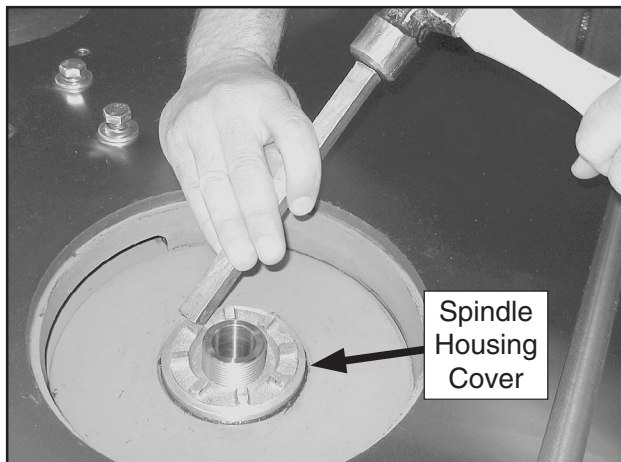

Figure 58. Removing the spindle housing cover.

6. Remove the internal retaining ring securing the spindle cartridge (see **Figure 59**).

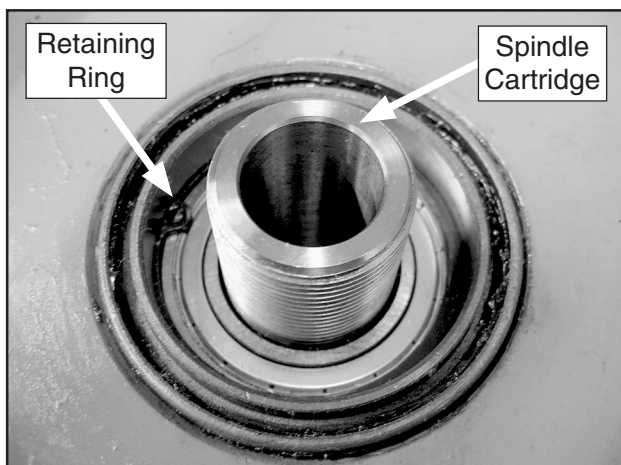

Figure 59. Retaining ring location.

7. Remove the V-belt from both pulleys, then remove the cap screw and flat washer that secure the spindle pulley (see **Figure 60**).

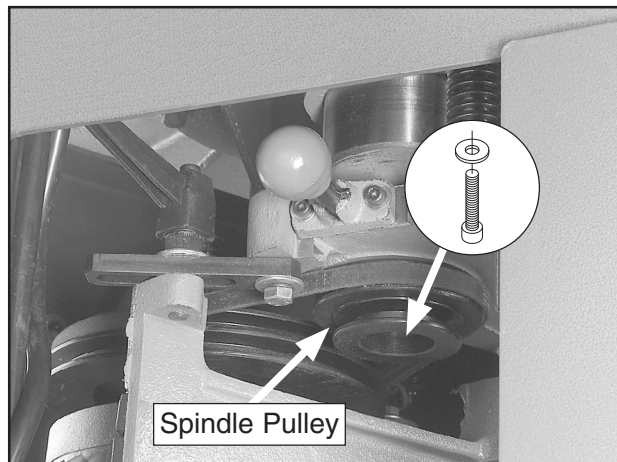

Figure 60. Spindle pulley.

8. Taking care to retain the key on the bottom of the spindle cartridge, remove the spindle pulley.
9. Place the 23" long 2x4 under the spindle cartridge, as shown in **Figure 61**, then use the height handwheel to lower the spindle housing until the cartridge is pushed up and can be removed from the top of the table.

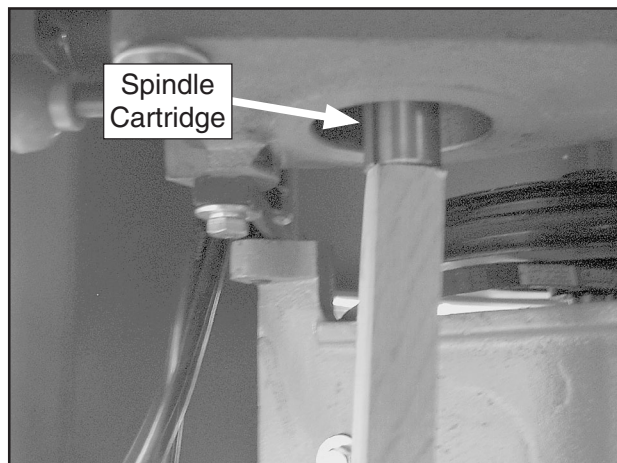

Figure 61. Forcing the spindle cartridge up.



10. Place the spindle cartridge between the 2x6's, as shown in **Figure 62**, then carefully use the dead blow hammer to force the cartridge down until the first bearing is removed.

Note: Do not use a metal hammer on the spindle cartridge to avoid damaging the rim or threads.

The bearings are different sizes. Take note of which size is removed from each end of the spindle cartridge to properly re-install them in **Step 12**.

Note: Use shop rags underneath the cartridge to avoid damaging it as it falls.

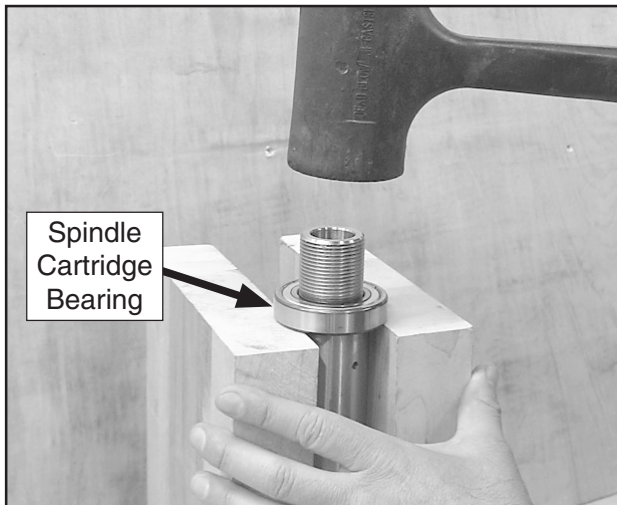

Figure 62. Removing the spindle cartridge bearing.

11. Repeat **Step 10** for the remaining bearing.
12. Examine the spindle cartridge bearings for wear or damage.
 - If the bearings are rough or show signs of excessive wear, replace them with new ones.

—If the bearings are still in good condition, re-install them using the 2x6's and the dead blow hammer, as shown in **Figure 63**. Take care to tap lightly on the spindle cartridge to seat the bearings, so as not to damage the bearings.

Note: The bearings are different sizes. Make sure to re-install them on the correct end of the spindle cartridge, as noted in **Step 10**.

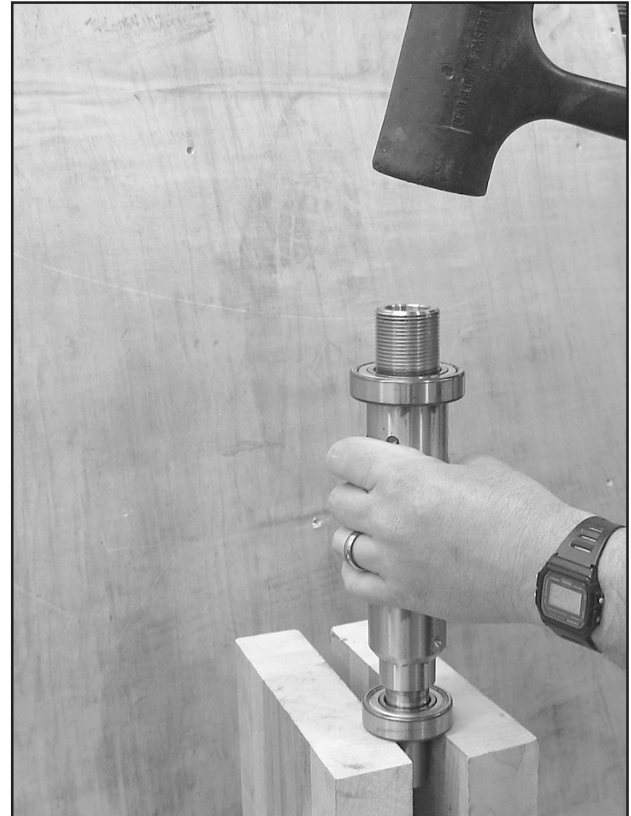

Figure 63. Re-installing the bearings.

13. Re-install the spindle cartridge and the other parts removed in reverse order.



SECTION 8: WIRING

These pages are current at the time of printing. However, in the spirit of improvement, we may make changes to the electrical systems of future machines. Study this section carefully. If there are differences between your machine and what is shown in this section, call Technical Support at (570) 546-9663 for assistance BEFORE making any changes to the wiring on your machine.

WARNING















Wiring Safety Instructions

- SHOCK HAZARD.** Working on wiring that is connected to a power source is extremely dangerous. Touching electrified parts will result in personal injury including but not limited to severe burns, electrocution, or death. Disconnect the power from the machine before servicing electrical components!
- QUALIFIED ELECTRICIAN.** Due to the inherent hazards of electricity, only a qualified electrician should perform wiring tasks on this machine. If you are not a qualified electrician, get help from one before attempting any kind of wiring job.
- WIRE CONNECTIONS.** All connections must be tight to prevent wires from loosening during machine operation. Double-check all wires disconnected or connected during any wiring task to ensure tight connections.
- WIRE/COMPONENT DAMAGE.** Damaged wires or components increase the risk of serious personal injury, fire, or machine damage. If you notice that any wires or components are damaged while performing a wiring task, replace those wires or components before completing the task.
- MODIFICATIONS.** Using aftermarket parts or modifying the wiring beyond what is shown in the diagram may lead to unpredictable results, including serious injury or fire.
- MOTOR WIRING.** The motor wiring shown in these diagrams is current at the time of printing, but it may not match your machine. Always use the wiring diagram inside the motor junction box.
- CAPACITORS.** Some capacitors store an electrical charge for up to five minutes after being disconnected from the power source. To avoid being shocked, wait at least this long before working on capacitors.
- CIRCUIT REQUIREMENTS.** You MUST follow the requirements on **Page 9** when connecting your machine to a power source.
- EXPERIENCING DIFFICULTIES.** If you are experiencing difficulties understanding the information included in this section, contact our Technical Support at (570) 546-9663.

NOTICE

The photos and diagrams included in this section are best viewed in color. You can view these pages in color at www.grizzly.com.

COLOR KEY

| | | | | | | | |
|-------|---|--------|---|--------------|---|------------|---|
| BLACK |  | BLUE |  | YELLOW |  | LIGHT BLUE |  |
| WHITE |  | BROWN |  | YELLOW GREEN |  | BLUE WHITE |  |
| GREEN |  | GRAY |  | PURPLE |  | TURQUOISE |  |
| RED |  | ORANGE |  | PINK |  | | |



Wiring Overview

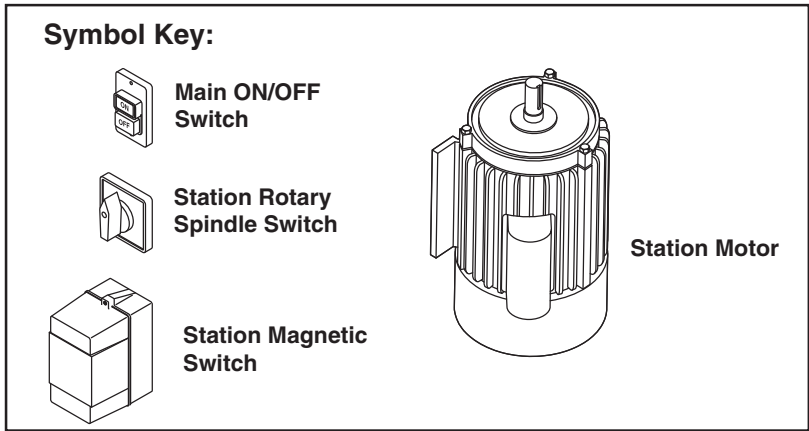
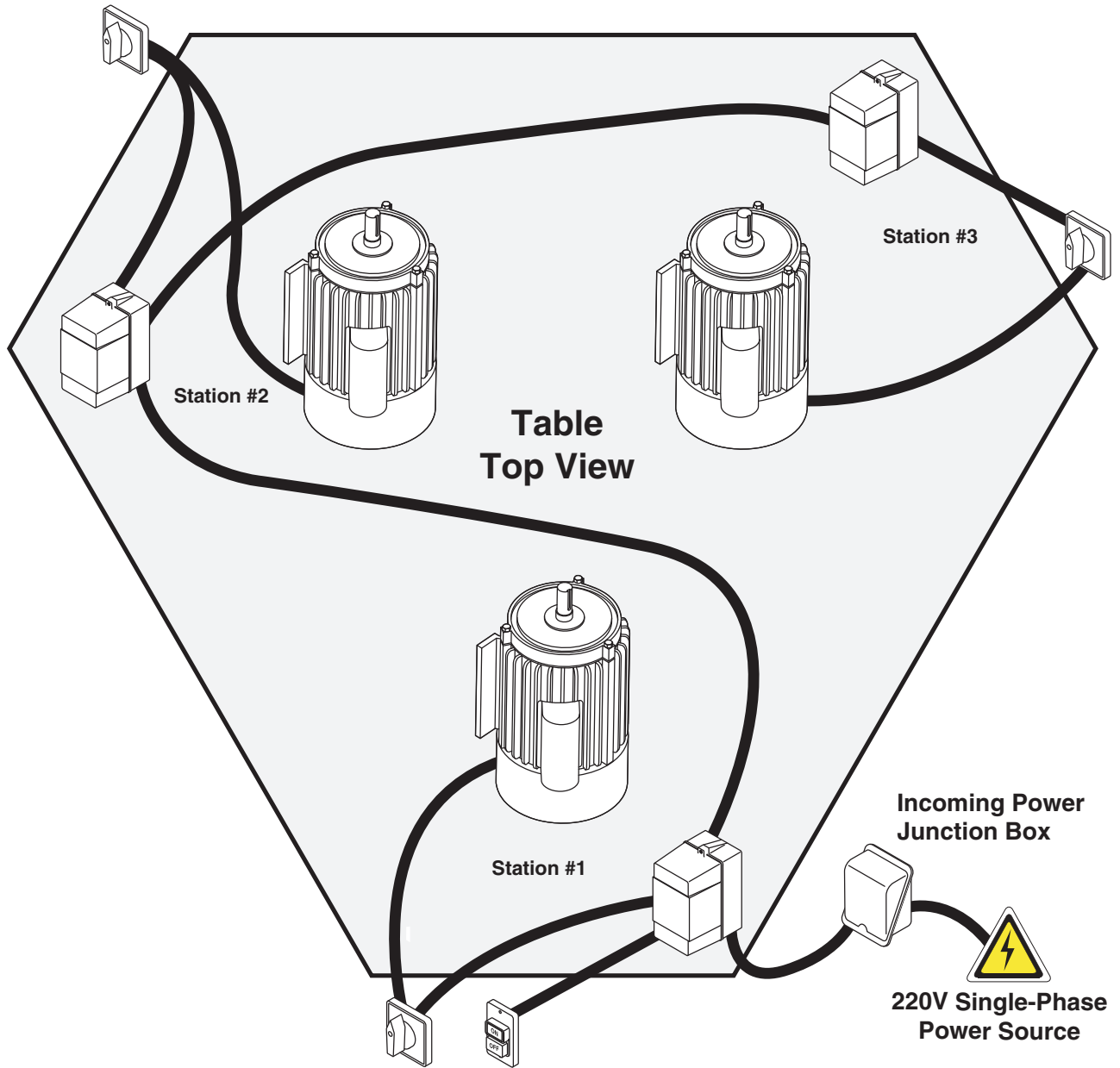

Wiring Diagram (A)

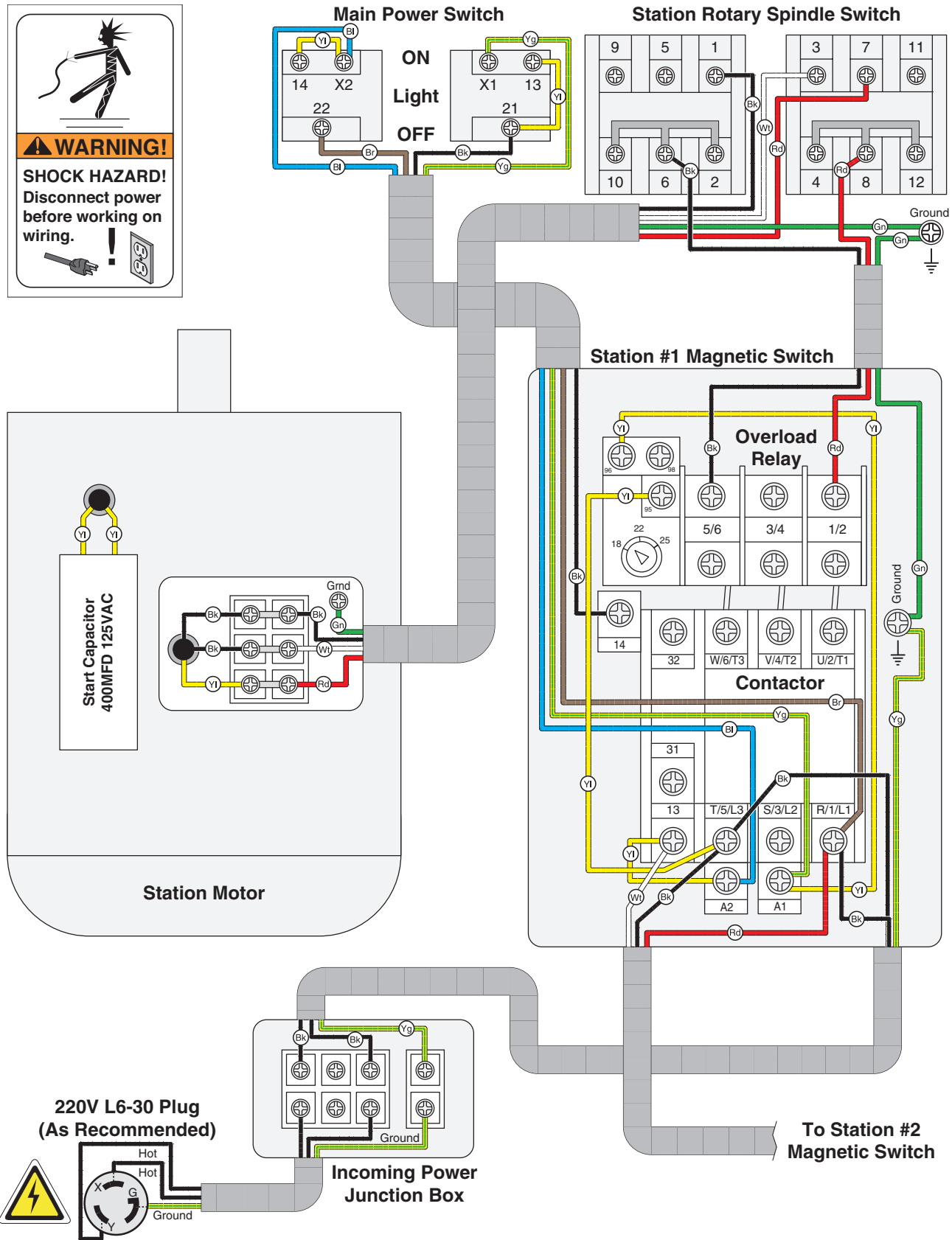
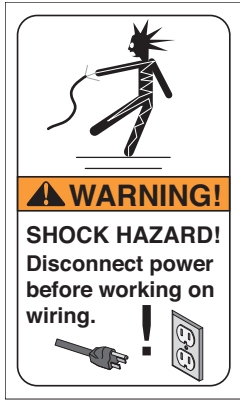

Wiring Diagram (B)

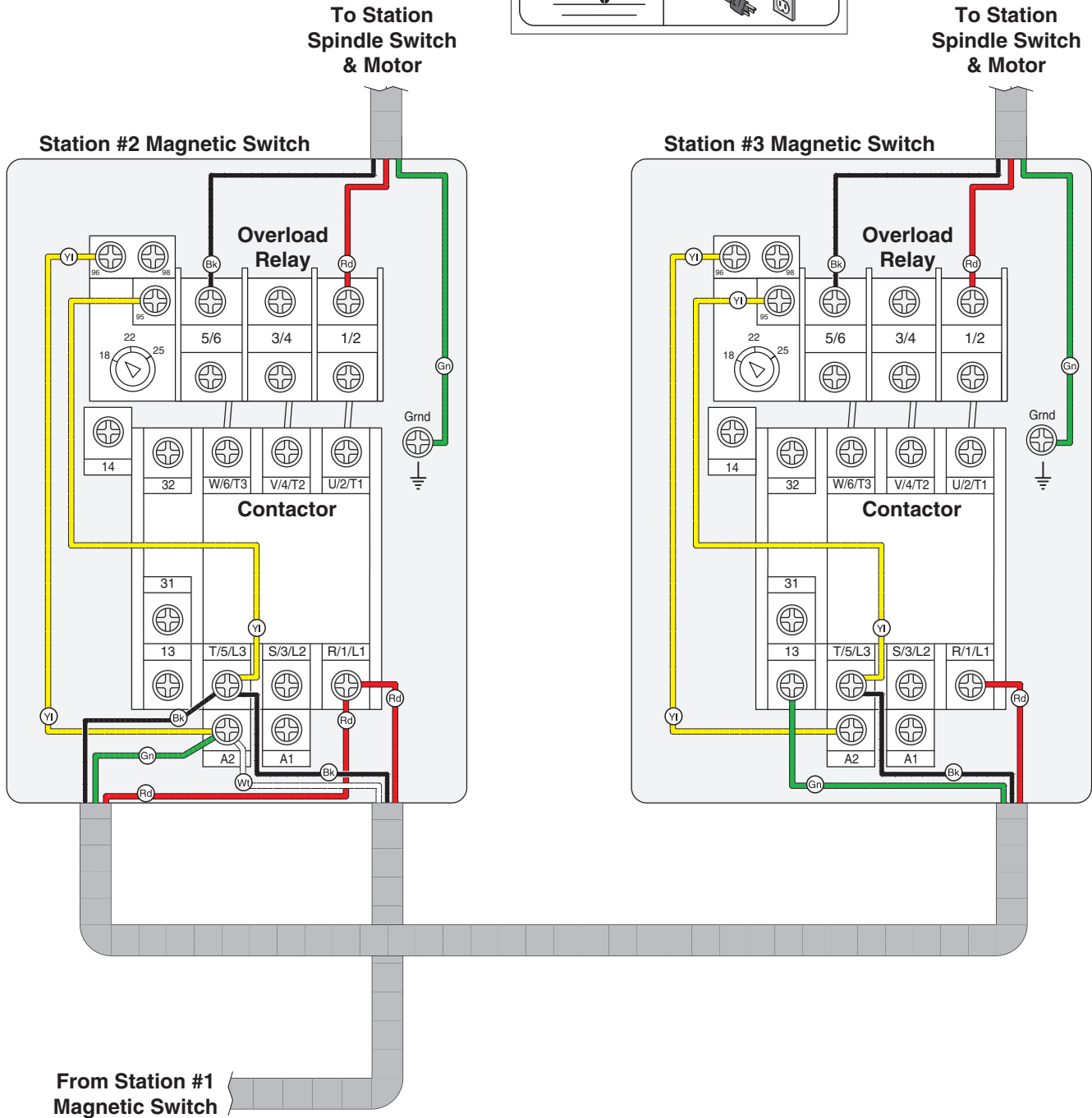

SECTION 9: PARTS

Motor & Spindle Breakdown

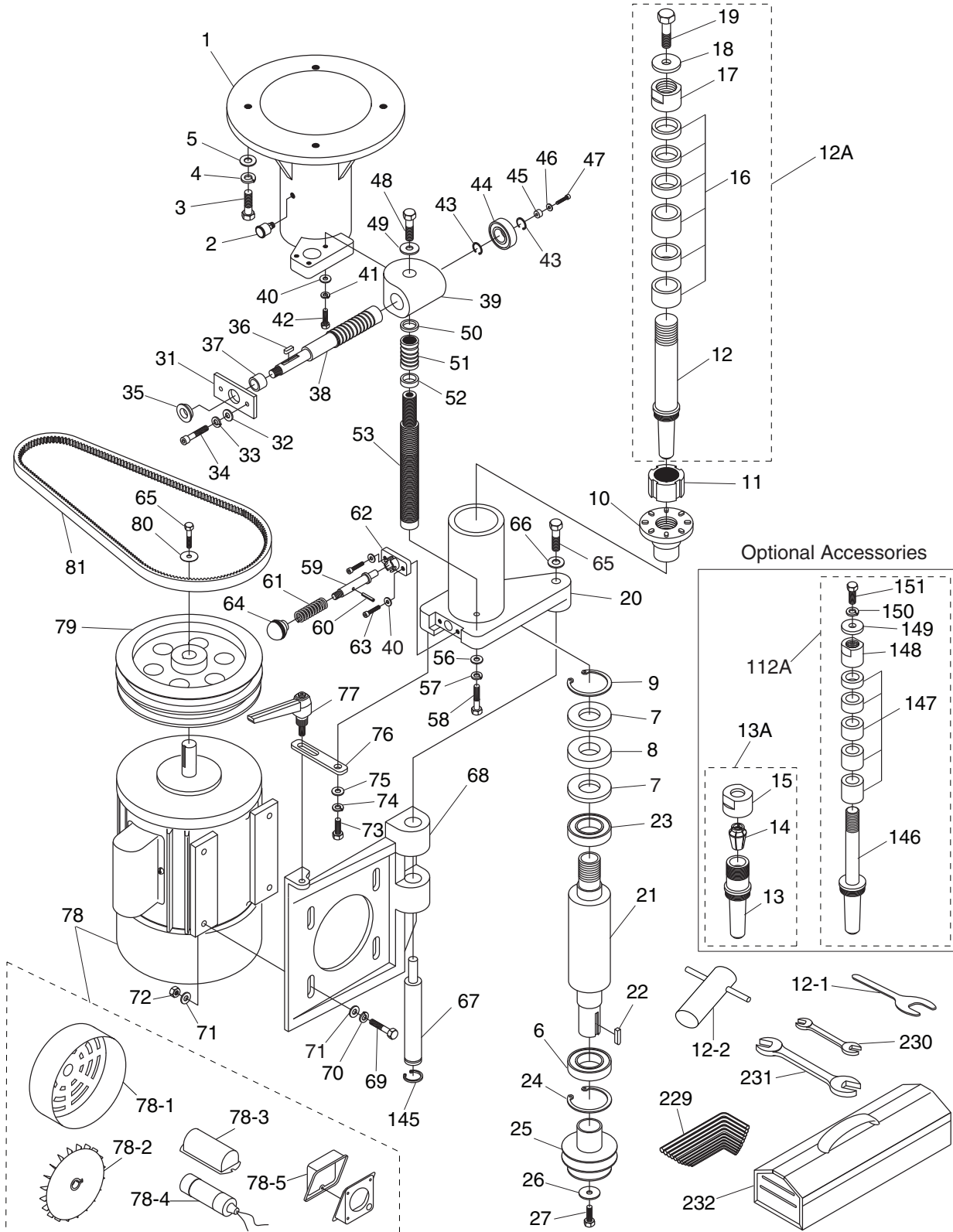

Motor & Spindle Parts List

| REF | PART # | DESCRIPTION |
|------|------------|----------------------------------|
| 1 | P9933001 | OUTER SPINDLE HOUSING |
| 2 | P9933002 | GREASE CUP ASSEMBLY |
| 3 | PB01M | HEX BOLT M10-1.5 X 30 |
| 4 | PLW06M | LOCK WASHER 10MM |
| 5 | PW04M | FLAT WASHER 10MM |
| 6 | P6205ZZ | BALL BEARING 6205ZZ |
| 7 | P9933007 | SPACER |
| 8 | P9933008 | SPACER |
| 9 | PR26M | INT RETAINING RING 52MM |
| 10 | P9933010 | SPINDLE HOUSING COVER |
| 11 | P9933011 | SPINDLE LOCK NUT 1-1/4"-7 |
| 12 | P9933012 | CUTTER SPINDLE 1-1/4" |
| 12-1 | P9933012-1 | SPINDLE WRENCH |
| 12-2 | P9933012-2 | SPINDLE KEY |
| 12A | P9933012A | CUTTER SPINDLE ASSEMBLY 1-1/4" |
| 13 | P9933013 | ROUTER BIT SPINDLE 1/2" |
| 13A | H0784 | ROUTER BIT SPINDLE ASSEMBLY 1/2" |
| 14 | P9933014 | ROUTER BIT COLLET 1/2" |
| 15 | P9933015 | ROUTER BIT COLLET NUT 1/2" |
| 16 | P9933016 | SPACER KIT 1-1/4" |
| 17 | P9933017 | SPINDLE NUT 1-1/4" |
| 18 | P9933018 | SPECIAL FLAT WASHER 12MM |
| 19 | PB25M | HEX BOLT M12-1.75 X 25 |
| 20 | P9933020 | INNER SPINDLE HOUSING |
| 21 | P9933021 | SPINDLE CARTRIDGE |
| 22 | PK61M | KEY 7 X 7 X 30 |
| 23 | P6007ZZ | BALL BEARING 6007ZZ |
| 24 | PR38M | INT RETAINING RING 62MM |
| 25 | P9933025 | SPINDLE PULLEY |
| 26 | P9933026 | SPECIAL WASHER M8 |
| 27 | PFH21M | FLAT HD SCR M8-1.25 X 25 |
| 31 | P9933031 | SUPPORT |
| 32 | PW01M | FLAT WASHER 8MM |
| 33 | PLW04M | LOCK WASHER 8MM |
| 34 | PSB11M | CAP SCREW M8-1.25 X 16 |
| 35 | P9933035 | PLASTIC SPACER |
| 36 | PK20M | KEY 5 X 5 X 15 |
| 37 | P9933037 | BUSHING |
| 38 | P9933038 | WORM SHAFT |
| 39 | P9933039 | GEAR HOUSING |
| 40 | PW03M | FLAT WASHER 6MM |
| 41 | PLW04M | LOCK WASHER 8MM |
| 42 | PB52M | HEX BOLT M6-1 X 35 |
| 43 | PR46M | INT RETAINING RING 27MM |
| 44 | P6000ZZ | BALL BEARING 6000ZZ |
| 45 | P9933045 | SPACER |
| 46 | PW02M | FLAT WASHER 5MM |
| 47 | PSB10M | CAP SCREW M5-.8 X 15 |
| 48 | PB03M | HEX BOLT M8-1.25 X 16 |

| REF | PART # | DESCRIPTION |
|------|------------|---------------------------------|
| 49 | PW01M | FLAT WASHER 8MM |
| 50 | P9933050 | THRUST WASHER |
| 51 | P9933051 | WORM GEAR |
| 52 | P9933052 | THRUST WASHER |
| 53 | P9933053 | WORM SHAFT |
| 56 | PW01M | FLAT WASHER 8MM |
| 57 | PLW04M | LOCK WASHER 8MM |
| 58 | PB20M | HEX BOLT M8-1.25 X 35 |
| 59 | P9933059 | LOCK PIN |
| 60 | PRP24M | ROLL PIN 5 X 16 |
| 61 | P9933061 | TENSION SPRING |
| 62 | P9933062 | SUPPORT |
| 63 | PSB28M | CAP SCREW M6-1 X 15 |
| 64 | P9933064 | KNOB |
| 65 | PB09M | HEX BOLT M8-1.25 X 20 |
| 66 | PW04M | FLAT WASHER 10MM |
| 67 | P9933067 | MOTOR PIVOT SHAFT |
| 68 | P9933068 | MOTOR SUPPORT |
| 69 | PB20M | HEX BOLT M8-1.25 X 35 |
| 70 | PLW04M | LOCK WASHER 8MM |
| 71 | PW01M | FLAT WASHER 8MM |
| 72 | PN03M | HEX NUT M8-1.25 |
| 73 | PB07M | HEX BOLT M8-1.25 X 25 |
| 74 | PLW04M | LOCK WASHER 8MM |
| 75 | PW04M | FLAT WASHER 10MM |
| 76 | P9933076 | ADJUSTABLE BRACKET |
| 77 | P9933077 | LOCK LEVER |
| 78 | P9933078 | MOTOR 3HP 220V 60HZ 1PH |
| 78-1 | P9933078-1 | MOTOR FAN COVER |
| 78-2 | P9933078-2 | MOTOR FAN |
| 78-3 | P9933078-3 | CAPACITOR COVER |
| 78-4 | P9933078-4 | S CAPACITOR 400M 125V 1-3/4 X 4 |
| 78-5 | P9933078-5 | MOTOR WIRING JUNCTION BOX |
| 79 | P9933079 | MOTOR PULLEY |
| 80 | PW01M | FLAT WASHER 8MM |
| 81 | PVM28 | V-BELT 3L280 |
| 112A | H0783 | CUTTER SPINDLE ASSY 3/4" |
| 145 | PR11M | EXT RETAINING RING 25MM |
| 146 | P9933146 | CUTTER SPINDLE 3/4" |
| 147 | P9933147 | SPACER KIT 3/4" |
| 148 | P9933148 | SPINDLE NUT 3/4" |
| 149 | P9933149 | SPECIAL FLAT WASHER 12MM |
| 150 | PLW04 | LOCK WASHER 3/8 |
| 151 | PB18 | HEX BOLT 3/8-16 X 1 |
| 229 | P9933229 | HEX WRENCH SET 1.5-10MM |
| 230 | PWR1113 | WRENCH 11 X 13 |
| 231 | PWR1719 | WRENCH 17 X 19 |
| 232 | P9933232 | TOOLBOX |



Cabinet & Table

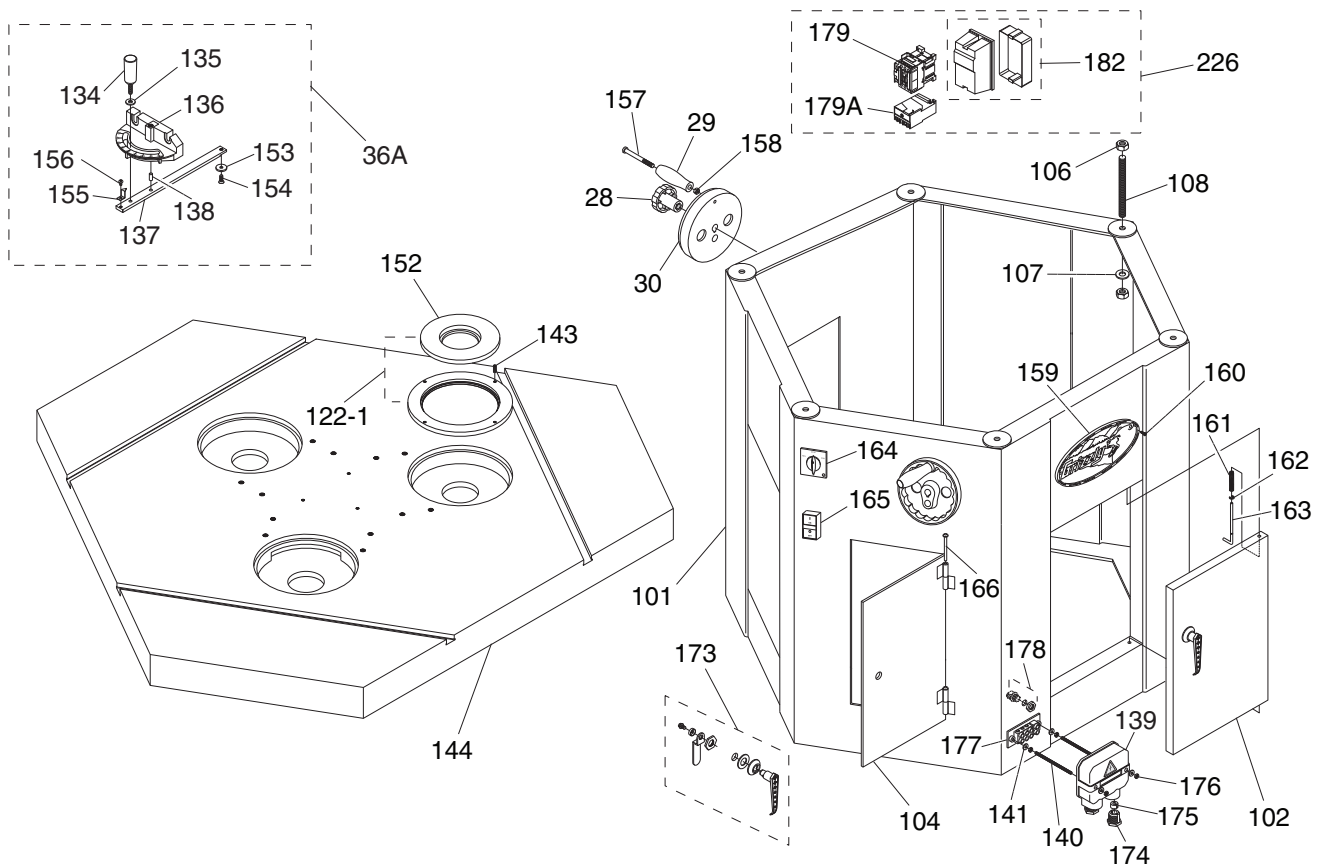

| REF | PART # | DESCRIPTION |
|-------|------------|-----------------------|
| 28 | P9933028 | STAR KNOB |
| 29 | P9933029 | HANDLE |
| 30 | P9933030 | HANDWHEEL |
| 36A | P9933036A | MITER GAUGE ASSY |
| 101 | P9933101 | CABINET FRAME |
| 102 | P9933102 | LARGE DOOR |
| 104 | P9933104 | SMALL DOOR |
| 106 | PN09M | HEX NUT M12-1.75 |
| 107 | PW06M | FLAT WASHER 12MM |
| 108 | P9933108 | STUD M12 X 70 |
| 122-1 | P9933122-1 | TABLE INSERT ASSEMBLY |
| 134 | P9933134 | KNOB |
| 135 | PW01M | FLAT WASHER 8MM |
| 136 | P9933136 | MITER GAUGE BODY |
| 137 | P9933137 | SLIDE PLATE |
| 138 | P9933138 | PIN 6 X 10 |
| 139 | P9933139 | TERMINAL BOARD COVER |
| 140 | P9933140 | STUD 10-24 X 64MM |
| 141 | PW02M | FLAT WASHER 5MM |
| 143 | PSS31M | SET SCREW M5-.8 X 8 |
| 144 | P9933144 | TABLE |
| 152 | P9933152 | INNER TABLE INSERT |
| 153 | P9933153 | T-SLOT WASHER |

| REF | PART # | DESCRIPTION |
|------|-----------|---------------------------|
| 154 | PS09 | PHLP HD SCR 1/4-20 X 1/4 |
| 155 | P9933155 | ANGLE INDICATOR |
| 156 | PS05M | PHLP HD SCR M5-.8 X 8 |
| 157 | P9933157 | SPECIAL BOLT M8-1.25 X 80 |
| 158 | PN02 | HEX NUT 5/16"-18 |
| 159 | G9987 | GRIZZLY OVAL NAMEPLATE |
| 160 | PHTEK15M | TAP SCREW M4 X 10 |
| 161 | P9933161 | COMPRESSION SPRING |
| 162 | PEC02M | E-CLIP 4MM |
| 163 | P9933163 | DOOR HINGE PIN |
| 164 | P9933164 | FORWARD/REVERSE SWITCH |
| 165 | P9933165 | ON/OFF SWITCH |
| 166 | P9933166 | HINGE PIN |
| 173 | P9933173 | DOOR HANDLE |
| 174 | P9933174 | STRAIN RELIEF |
| 175 | P9933175 | RUBBER WASHER |
| 176 | PN07 | HEX NUT 10-24 |
| 177 | P9933177 | TERMINAL BLOCK 9 POST |
| 178 | P9933178 | STRAIN RELIEF |
| 179 | P9933179 | CONTACTOR GTM-19A 220V |
| 179A | P9933179A | OL RELAY GTH-20 12-18A |
| 182 | P9933182 | MAGNETIC SWITCH BOX |
| 226 | P9933226 | MAGNETIC SWITCH ASSEMBLY |



Fence & Guard Assembly

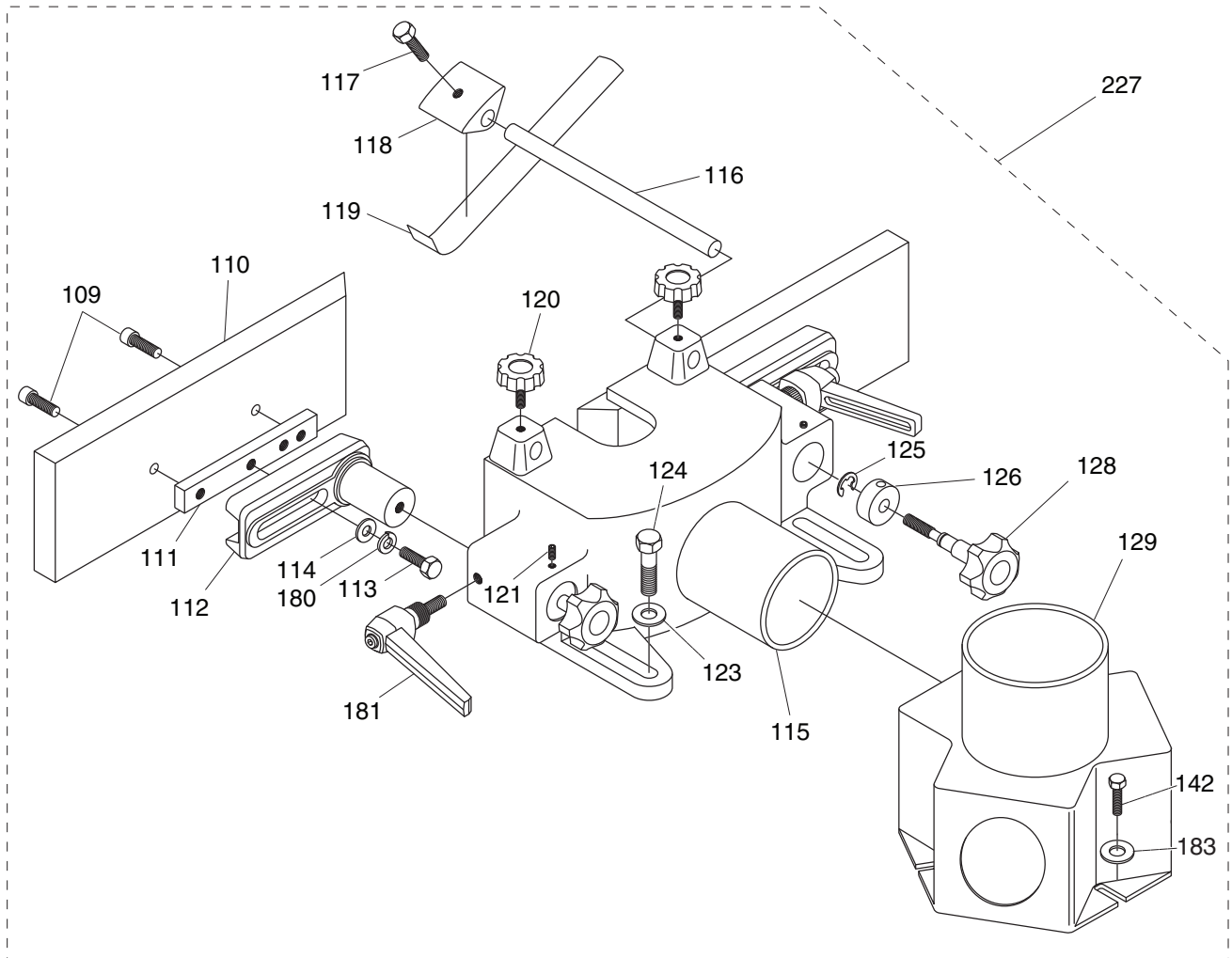

| REF | PART # | DESCRIPTION |
|-----|----------|------------------------|
| 109 | PSB14M | CAP SCREW M8-1.25 X 20 |
| 110 | P9933110 | FENCE BOARD |
| 111 | P9933111 | FENCE RAIL |
| 112 | P9933112 | FENCE MOUNT |
| 113 | PB07M | HEX BOLT M8-1.25 X 25 |
| 114 | PW01M | FLAT WASHER 8MM |
| 115 | P9933115 | SPINDLE GUARD |
| 116 | P9933116 | HOLD-DOWN SHAFT |
| 117 | PB09M | HEX BOLT M8-1.25 X 20 |
| 118 | P9933118 | HOLD-DOWN SUPPORT |
| 119 | P9933119 | HOLD-DOWN FINGER |
| 120 | P9933120 | ADJUSTMENT KNOB |

| REF | PART # | DESCRIPTION |
|-----|----------|-------------------------|
| 121 | PSS03M | SET SCREW M6-1 X 8 |
| 123 | PW04M | FLAT WASHER 10MM |
| 124 | PB32M | HEX BOLT M10-1.5 X 25 |
| 125 | PEC03M | E-CLIP 10MM |
| 126 | P9933126 | LOCK COLLAR |
| 128 | P9933128 | KNOB WITH SPECIAL SCREW |
| 129 | P9933129 | DUST HOOD |
| 142 | PB02M | HEX BOLT M6-1 X 12 |
| 180 | PLW04M | LOCK WASHER 8MM |
| 181 | P9933077 | LOCK LEVER |
| 183 | PW03M | FLAT WASHER 6MM |
| 227 | P9933227 | FENCE & GUARD ASSEMBLY |



Label Placement

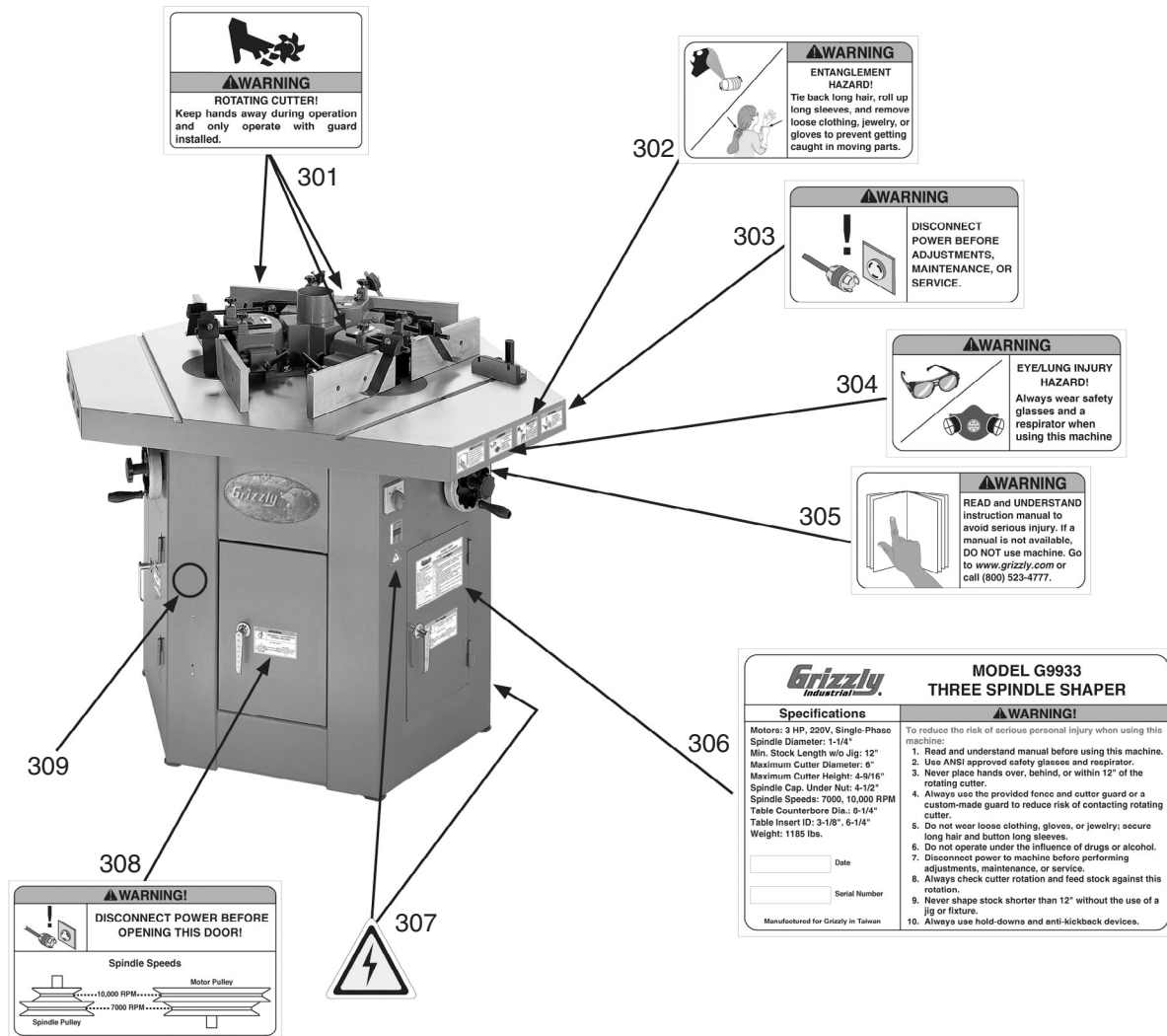

| REF | PART # | DESCRIPTION |
|-----|------------|---------------------------|
| 301 | P9933301 | CUTTER HAZARD LABEL |
| 302 | PLABEL-55B | ENTANGLEMENT HAZARD LABEL |
| 303 | PLABEL-63B | DISCONNECT POWER LABEL |
| 304 | PLABEL-57B | EYE/LUNG HAZARD LABEL |
| 305 | PLABEL-12B | READ MANUAL LABEL |

| REF | PART # | DESCRIPTION |
|-----|-----------|------------------------------|
| 306 | P9933306 | MACHINE ID LABEL |
| 307 | PLABEL-14 | ELECTRICITY LABEL |
| 308 | P9933308 | DISCONNECT POWER DOOR LABEL |
| 309 | PPAINT-1 | GRIZZLY GREEN TOUCH-UP PAINT |

⚠️ WARNING

Safety labels warn about machine hazards and ways to prevent injury. The owner of this machine **MUST** maintain the original location and readability of the labels on the machine. If any label is removed or becomes unreadable, **REPLACE** that label before using the machine again. Contact Grizzly at (800) 523-4777 or www.grizzly.com to order new labels.





WARRANTY CARD

Name _____

Street _____

City _____ State _____ Zip _____

Phone # _____ Email _____ Invoice # _____

Model # _____ Order # _____ Serial # _____

*The following information is given on a voluntary basis. It will be used for marketing purposes to help us develop better products and services. **Of course, all information is strictly confidential.***

1. How did you learn about us?

- | | | |
|--|----------------------------------|----------------------------------|
| <input type="checkbox"/> Advertisement | <input type="checkbox"/> Friend | <input type="checkbox"/> Catalog |
| <input type="checkbox"/> Card Deck | <input type="checkbox"/> Website | <input type="checkbox"/> Other: |

2. Which of the following magazines do you subscribe to?

- | | | |
|---|--|---|
| <input type="checkbox"/> Cabinet Maker | <input type="checkbox"/> Popular Mechanics | <input type="checkbox"/> Today's Homeowner |
| <input type="checkbox"/> Family Handyman | <input type="checkbox"/> Popular Science | <input type="checkbox"/> Wood |
| <input type="checkbox"/> Hand Loader | <input type="checkbox"/> Popular Woodworking | <input type="checkbox"/> Wooden Boat |
| <input type="checkbox"/> Handy | <input type="checkbox"/> Practical Homeowner | <input type="checkbox"/> Woodshop News |
| <input type="checkbox"/> Home Shop Machinist | <input type="checkbox"/> Precision Shooter | <input type="checkbox"/> Woodsmith |
| <input type="checkbox"/> Journal of Light Cont. | <input type="checkbox"/> Projects in Metal | <input type="checkbox"/> Woodwork |
| <input type="checkbox"/> Live Steam | <input type="checkbox"/> RC Modeler | <input type="checkbox"/> Woodworker West |
| <input type="checkbox"/> Model Airplane News | <input type="checkbox"/> Rifle | <input type="checkbox"/> Woodworker's Journal |
| <input type="checkbox"/> Modeltec | <input type="checkbox"/> Shop Notes | <input type="checkbox"/> Other: |
| <input type="checkbox"/> Old House Journal | <input type="checkbox"/> Shotgun News | |

3. What is your annual household income?

- | | | |
|--|--|--|
| <input type="checkbox"/> \$20,000-\$29,000 | <input type="checkbox"/> \$30,000-\$39,000 | <input type="checkbox"/> \$40,000-\$49,000 |
| <input type="checkbox"/> \$50,000-\$59,000 | <input type="checkbox"/> \$60,000-\$69,000 | <input type="checkbox"/> \$70,000+ |

4. What is your age group?

- | | | |
|--------------------------------|--------------------------------|--------------------------------|
| <input type="checkbox"/> 20-29 | <input type="checkbox"/> 30-39 | <input type="checkbox"/> 40-49 |
| <input type="checkbox"/> 50-59 | <input type="checkbox"/> 60-69 | <input type="checkbox"/> 70+ |

5. How long have you been a woodworker/metalworker?

- | | | | |
|------------------------------------|------------------------------------|-------------------------------------|------------------------------------|
| <input type="checkbox"/> 0-2 Years | <input type="checkbox"/> 2-8 Years | <input type="checkbox"/> 8-20 Years | <input type="checkbox"/> 20+ Years |
|------------------------------------|------------------------------------|-------------------------------------|------------------------------------|

6. How many of your machines or tools are Grizzly?

- | | | | |
|------------------------------|------------------------------|------------------------------|------------------------------|
| <input type="checkbox"/> 0-2 | <input type="checkbox"/> 3-5 | <input type="checkbox"/> 6-9 | <input type="checkbox"/> 10+ |
|------------------------------|------------------------------|------------------------------|------------------------------|

7. Do you think your machine represents a good value? Yes No

8. Would you recommend Grizzly Industrial to a friend? Yes No

9. Would you allow us to use your name as a reference for Grizzly customers in your area?
Note: We never use names more than 3 times. Yes No

10. Comments: _____

CUT ALONG DOTTED LINE

FOLD ALONG DOTTED LINE



Place
Stamp
Here



GRIZZLY INDUSTRIAL, INC.
P.O. BOX 2069
BELLINGHAM, WA 98227-2069



FOLD ALONG DOTTED LINE

Send a Grizzly Catalog to a friend:

| |
|----------------------------------|
| Name _____ |
| Street _____ |
| City _____ State _____ Zip _____ |

TAPE ALONG EDGES--PLEASE DO NOT STAPLE

WARRANTY AND RETURNS

Grizzly Industrial, Inc. warrants every product it sells for a period of **1 year** to the original purchaser from the date of purchase. This warranty does not apply to defects due directly or indirectly to misuse, abuse, negligence, accidents, repairs or alterations or lack of maintenance. This is Grizzly's sole written warranty and any and all warranties that may be implied by law, including any merchantability or fitness, for any particular purpose, are hereby limited to the duration of this written warranty. We do not warrant or represent that the merchandise complies with the provisions of any law or acts unless the manufacturer so warrants. In no event shall Grizzly's liability under this warranty exceed the purchase price paid for the product and any legal actions brought against Grizzly shall be tried in the State of Washington, County of Whatcom.

We shall in no event be liable for death, injuries to persons or property or for incidental, contingent, special, or consequential damages arising from the use of our products.

To take advantage of this warranty, contact us by mail or phone and give us all the details. We will then issue you a "Return Number," which must be clearly posted on the outside as well as the inside of the carton. We will not accept any item back without this number. Proof of purchase must accompany the merchandise.

The manufacturers reserve the right to change specifications at any time because they constantly strive to achieve better quality equipment. We make every effort to ensure that our products meet high quality and durability standards and we hope you never need to use this warranty.

Please feel free to write or call us if you have any questions about the machine or the manual.

Thank you again for your business and continued support. We hope to serve you again soon.

grizzly.com[®]
TOOL WEBSITE

Buy Direct and Save with Grizzly[®] – Trusted, Proven and a Great Value!
~Since 1983~

*Visit Our Website Today For
Current Specials!*

**ORDER
24 HOURS A DAY!
1-800-523-4777**

