

READ THIS FIRST



Model G0637/G0638
*****IMPORTANT UPDATE*****
For Machines Mfd. Since 10/20
and Manual Revised 1/18

For questions or help with this product contact Tech Support at (570) 546-9663 or techsupport@grizzly.com

The following changes were made since the owner's manual was printed:

- Instead of two round collection drums, there is now one square drum with a handle for hood raising.
- The frame now has square holes for carriage bolts.

Aside from this information, all other content in the owner's manual applies and **MUST** be read and understood for your own safety. **IMPORTANT: Keep this update with the owner's manual for future reference.**

For questions or help, contact our Tech Support at (570) 546-9663 or techsupport@grizzly.com.

Revised G0637 Specifications

Product Dimensions:

Width (side-to-side) x Depth (front-to-back) x Height 76-1/2 x 60-1/2 x 129 in.
Footprint (Length x Width) 51 x 51 in.

Revised G0638 Specifications

Product Dimensions:

Width (side-to-side) x Depth (front-to-back) x Height 79-1/2 x 60-1/2 x 129 in.
Footprint (Length x Width) 79-1/2 x 51 in.

Revised Shared Specifications

Main Specifications:

Operation

Maximum Material Capacity At One Time 12 cu. ft.

Bag Information

Collection Drum Bag Diameter 47-3/16 in.
Collection Drum Bag Length 49-3/16 in.

Canister Information

Collection Drum Size 115 Gallons

Revised Needed for Setup

Description

Qty

- Caulk/Silicone As Needed
- Open-End Wrench or Socket 10mm 1
- Open-End Wrenches 1/2", 9/16" 2 Ea.

COPYRIGHT © OCTOBER, 2020 BY GRIZZLY INDUSTRIAL, INC.
**WARNING: NO PORTION OF THIS MANUAL MAY BE REPRODUCED IN ANY SHAPE
OR FORM WITHOUT THE WRITTEN APPROVAL OF GRIZZLY INDUSTRIAL, INC.**
#CS21428 PRINTED IN TAIWAN

Revised Parts Breakdown

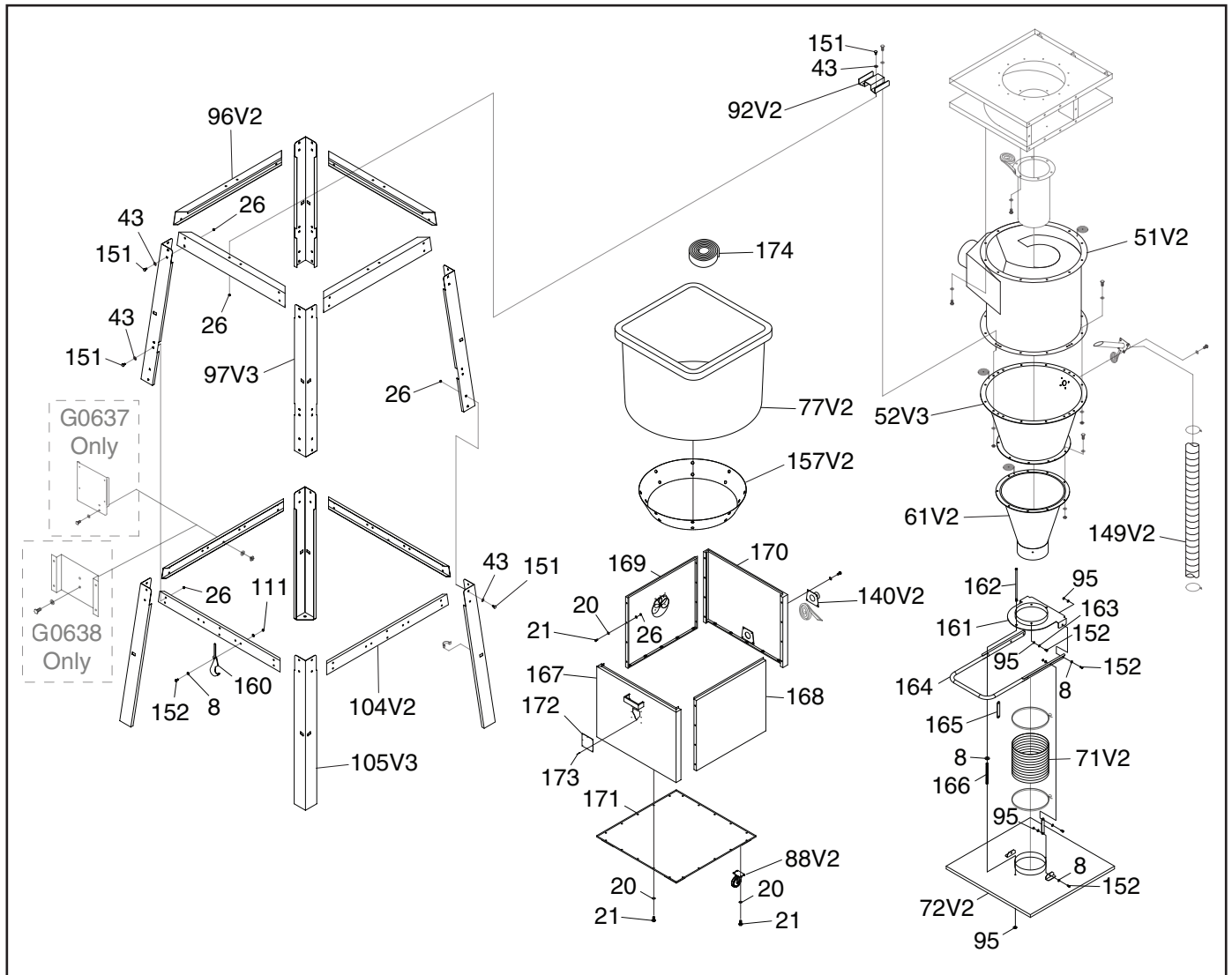

REF	PART #	DESCRIPTION
8	P0637008	FLAT WASHER 3/8
20	P0637020	FLAT WASHER 5/16
21	P0637021	HEX BOLT 5/16-18 X 3/4
26	P0637026	HEX NUT 5/16-18
43	P0637043	FLAT WASHER 5/16
51V2	P0637051V2	INTAKE BARREL V2.10.20
52V3	P0637052V3	LARGE CYCLONE FUNNEL V3.10.20
61V2	P0637061V2	SMALL CYCLONE FUNNEL V2.10.20
71V2	P0637071V2	FLEXIBLE DUCT 9 X 9-1/2" V2.10.20
72V2	P0637072V2	COLLECTION DRUM LID V2.10.20
77V2	P0637077V2	DRUM COLLECTION BAG 1.2 X 1.25M V2.10.20
88V2	P0637088V2	CASTER 4" V2.10.20
92V2	P0637092V2	CYCLONE MOUNTING BRACKET V2.10.20
95	P0637095	LOCK NUT 3/8-16
96V2	P0637096V2	UPPER STAND BRACE V2.10.20
97V3	P0637097V3	UPPER STAND LEG V3.10.20
104V2	P0637104V2	LOWER STAND BRACE V2.10.20
105V3	P0637105V3	LOWER STAND LEG V3.10.20
111	P0637111	LOCK NUT 3/8-16
140V2	P0637140V2	COLLECTION DRUM VACUUM TUBE V2.10.20

REF	PART #	DESCRIPTION
149V2	P0637149V2	VACUUM HOSE 2" X 118-1/8" V2.10.20
151	P0637151	CARRIAGE BOLT 5/16-18 X 3/4
152	P0637152	HEX BOLT 3/8-16 X 1
157V2	P0637157V2	COLLECTION DRUM VACUUM RING V2.10.20
160	P0637160	HANDLE HOOK
161	P0637161	CYCLONE FUNNEL ADAPTER
162	P0637162	HEX BOLT 3/8-16 X 11
163	P0637163	FLAT WASHER 3/8 THIN
164	P0637164	COLLECTION LID HANDLE
165	P0637165	DRUM LID CONNECTING PLATE
166	P0637166	DRUM LID SPRING
167	P0637167	FRONT DRUM PANEL
168	P0637168	LEFT DRUM PANEL
169	P0637169	RIGHT DRUM PANEL
170	P0637170	REAR DRUM PANEL
171	P0637171	BASE DRUM PANEL
172	P0637172	DRUM WINDOW
173	P0637173	RIVET
174	P0637174	DRUM LIP PVC SEAL 3100MM



Inventory

The following is a list of items shipped with your machine. Before beginning setup, lay these items out and inventory them.

If any non-proprietary parts are missing (e.g. a nut or a washer), we will gladly replace them; or for the sake of expediency, replacements can be obtained at your local hardware store.

NOTICE

If you cannot find an item on this list, carefully check around/inside the machine and packaging materials. Often, these items get lost in packaging materials while unpacking or they are pre-installed at the factory.

After all the parts have been removed from the boxes, you should have the following items:

Inventory: (Figures 1–5)	Qty
A. Upper Stand Braces	4
B. Upper Stand Legs	4
C. Filter Brace Supports (Long)	2
D. Filter Brace Support (Short)	1
E. Cyclone Mounting Brackets	4
F. Lower Stand Legs	4
G. Filter L-Braces	2
H. Lower Stand Braces	4

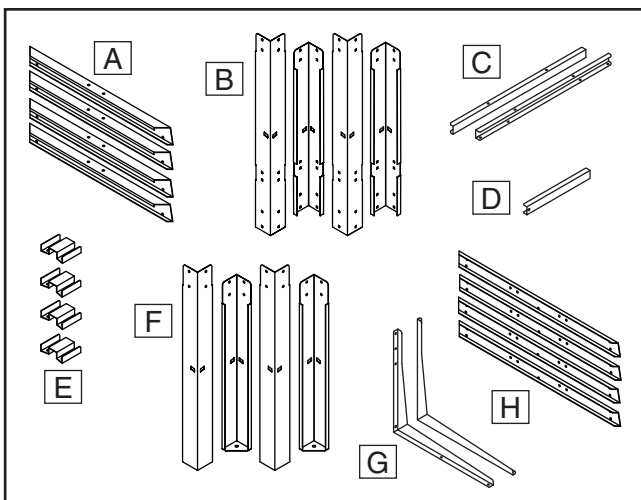

Figure 1. Model G0637/G0638 inventory A–H.

I. Intake Cylinder	1
J. Outlet Port	1
K. Cyclone Funnel (Large)	1

L. Intake Barrel	1
M. Cyclone Funnel (Small)	1

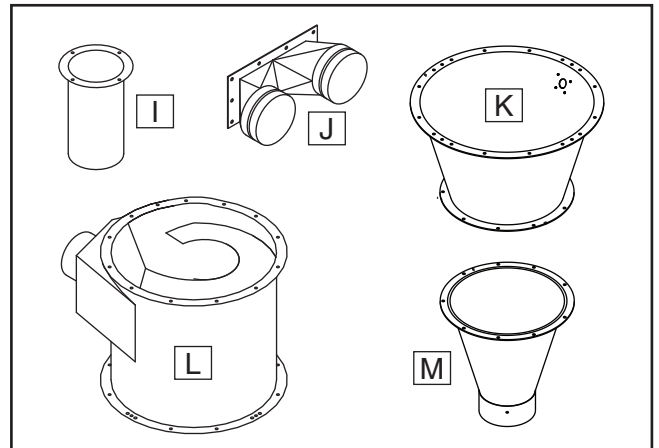

Figure 2. Model G0637/G0638 inventory I–M.

N. Blower Housing with Motor	1
O. Remote Control	1
P. Casters 4"	4
Q. Front Drum Panel	1
R. Left Drum Panel	1
S. Collection Drum Lid	1
T. Rear Drum Panel	1
U. Right Drum Panel	1
V. Base Drum Panel	1
W. Cyclone Funnel Adapter	1
X. Drum Lid Connecting Plates	2
Y. Collection Lid Handle	1

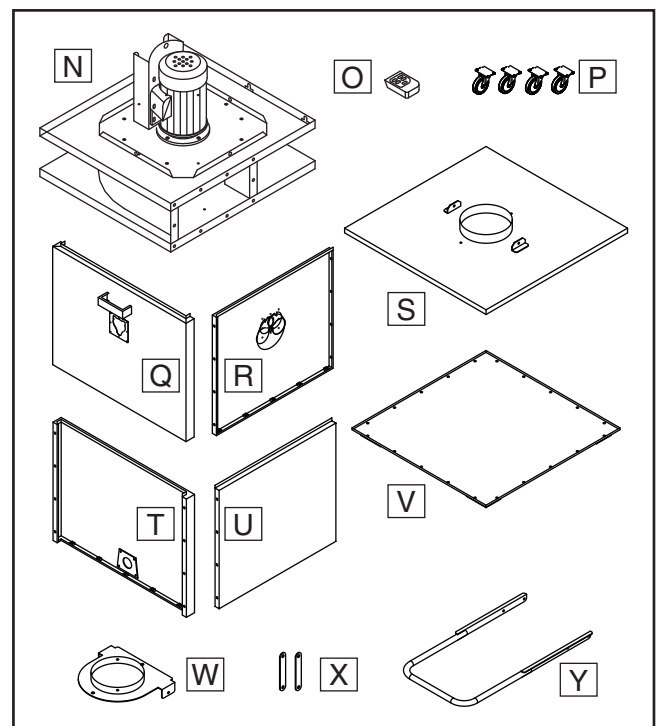

Figure 3. Model G0637/G0638 inventory N–Y.



Z.	Flexible Duct 9" x 9½"	1
AA.	Noise Mufflers	2
AB.	Canister Filters	
—	Model G0637 510 x 1200mm	2
—	Model G0638 510 x 1500mm	2
AC.	Flexible Ducts 8" x 31½"	2
AD.	Flexible Ducts 8" x 4¾"	2
AE.	Canister Filter Bag Clamps	2

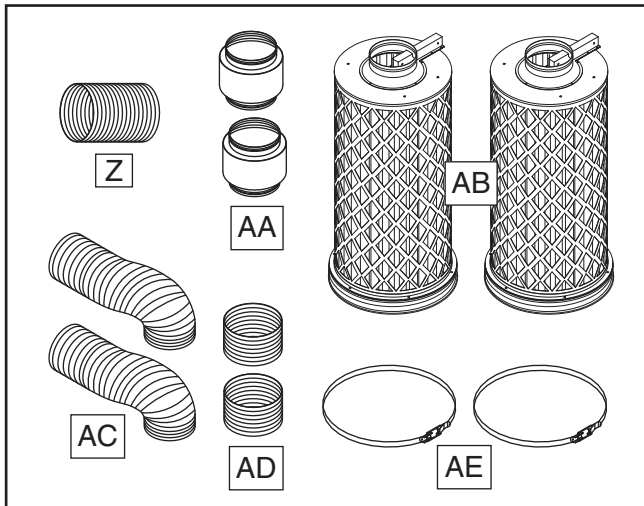

Figure 4. Model G0637/G0638 inventory Z–AE.

AF.	Vacuum Hose Clamps 2"	2
AG.	Vacuum Hose 2" x 118-1/8"	1
AH.	Vacuum Hose Clips	2
AI.	Collection Drum Vacuum Port	1
AJ.	Cyclone Vacuum Port	1
AK.	Drum Lid Springs	2
AL.	Handle Hook	1
AM.	Collection Drum Vacuum Ring	1
AN.	Control Box (G0637)	1
AO.	Control Box (G0638)	1
AP.	Control Box Bracket (G0638)	1

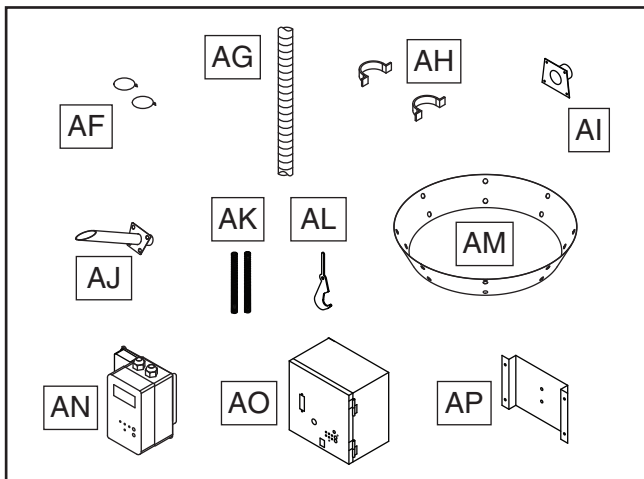

Figure 5. Model G0637/G0638 inventory AF–AP.

AQ.	Rubber Gasket (Outlet Port)	1
AR.	Gasket 3 x 6 x 1800mm (Intake Cylinder)	1
AS.	Rubber Gasket (Small Funnel)	1
AT.	Rubber Gasket (Intake Barrel & Large Funnel)	2
AU.	Gaskets 3 x 15 x 700mm	8
AV.	Drum Lid PVC Rubber Seal 3.1M	1
AW.	Foam Tape 5 x 50 x 2000mm	2
AX.	Filter Canister Gaskets	4
AY.	Duct Clamps 8" (not shown)	8
AZ.	Duct Clamps 9" (not shown)	2
BA.	Collection Bags (not shown):	
—	Collection Drum 1200 x 1250mm	1
—	Canister Filters 570 x 600mm	2
BB.	Hardware (not shown):	
—	Hex Bolts ⅜"-16 x 11"	2
—	Hex Bolts ⅜"-16 x 1¼"	8
—	Hex Bolts ⅜"-16 x 1"	11
—	Hex Bolts ⅝"-18 x 1¼"	21
—	Hex Bolts ⅝"-18 x 1"	10
—	Hex Bolts ⅝"-18 x ¾"	86
—	Carriage Bolts ⅝"-18 x ¾"	56
—	Flat Washers ⅜" (Thin)	8
—	Flat Washers ⅝"	212
—	Fender Washers ⅝"	8
—	Hex Nuts ⅝"-18	103
—	Lock Nuts ⅜"-16	21
	G0637 (Only)	
—	Hex Bolts ⅜"-16 x ¾"	9
—	Flat Washers ⅜"	52
—	Hex Nuts ⅜"-16	9
	G0638 (Only)	
—	Hex Bolts ⅜"-16 x ¾"	8
—	Phillips Head Screws M6-1 x 15	4
—	Flat Washers ⅜"	50
—	Flat Washers 6mm	4
—	Hex Nuts ⅜"-16	8
—	Hex Nuts M6-1	4



Site Considerations

Weight Load

Refer to the **Machine Data Sheet** for the weight of your machine. Make sure that the surface upon which the machine is placed will bear the weight of the machine, additional equipment that may be installed on the machine, and the heaviest workpiece that will be used. Additionally, consider the weight of the operator and any dynamic loading that may occur when operating the machine.

Space Allocation

Consider the largest size of workpiece that will be processed through this machine and provide enough space around the machine for adequate operator material handling or the installation of auxiliary equipment. With permanent installations, leave enough space around the machine to open or remove doors/covers as required by the maintenance and service described in this manual. **See below for required space allocation.**

	<p>CAUTION</p> <p>Children or untrained people may be seriously injured by this machine. Only install in an access restricted location.</p>
---	--

Physical Environment

The physical environment where the machine is operated is important for safe operation and longevity of machine components. For best results, operate this machine in a dry environment that is free from excessive moisture, hazardous chemicals, airborne abrasives, or extreme conditions. Extreme conditions for this type of machinery are generally those where the ambient temperature range exceeds 41°–104°F; the relative humidity range exceeds 20%–95% (non-condensing); or the environment is subject to vibration, shocks, or bumps.

Electrical Installation

Place this machine near an existing power source. Make sure all power cords are protected from traffic, material handling, moisture, chemicals, or other hazards. Make sure to leave enough space around machine to disconnect power supply or apply a lockout/tagout device, if required.

Lighting

Lighting around the machine must be adequate enough that operations can be performed safely. Shadows, glare, or strobe effects that may distract or impede the operator must be eliminated.

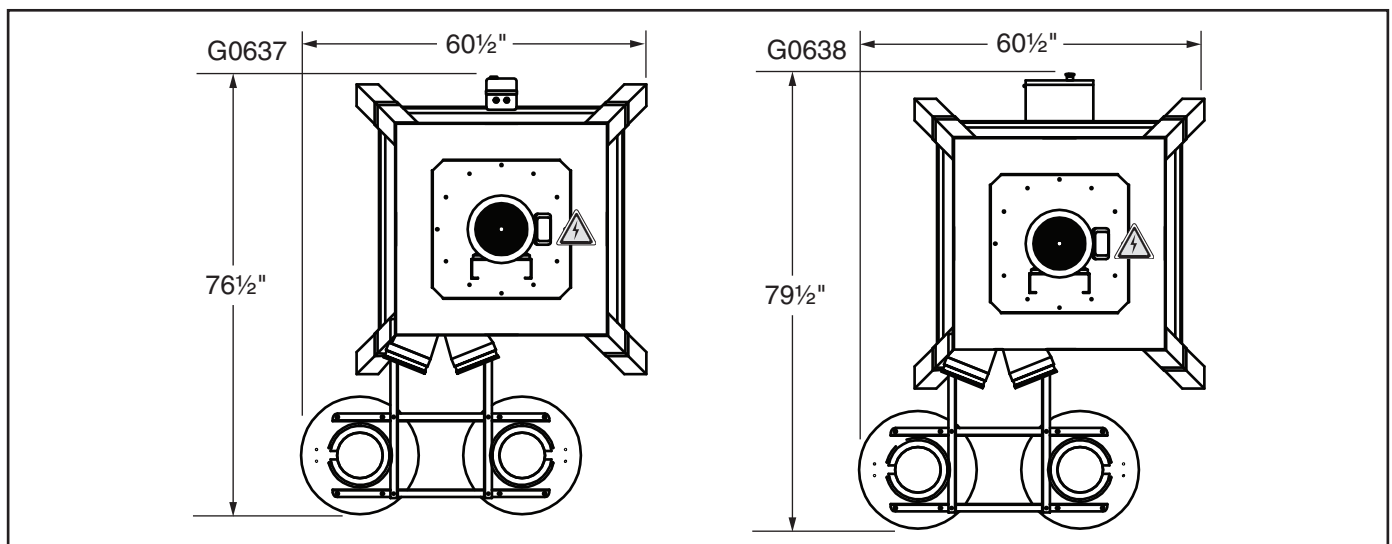

Figure 6. Minimum working clearances.



Mounting to Shop Floor

Number of Mounting Holes 4
Diameter of Mounting Hardware..... 9/16"

Anchoring machinery to the floor prevents tipping or shifting and reduces vibration that may occur during operation, resulting in a machine that runs slightly quieter and feels more solid.

If the machine will be installed in a commercial or workplace setting, or if it is permanently connected (hardwired) to the power supply, local codes may require that it be anchored to the floor.

If not required by any local codes, fastening the machine to the floor is an optional step. If you choose not to do this with your machine, we recommend placing it on machine mounts, as these provide an easy method for leveling and they have vibration-absorbing pads.

Anchoring to Concrete Floors

Lag shield anchors with lag screws (see below) are a popular way to anchor machinery to a concrete floor, because the anchors sit flush with the floor surface, making it easy to unbolt and move the machine later, if needed. However, anytime local codes apply, you **MUST** follow the anchoring methodology specified by the code.

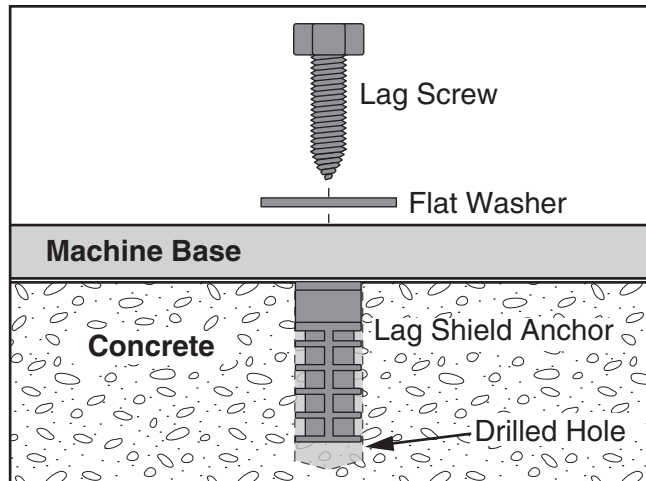

Figure 7. Popular method for anchoring machinery to a concrete floor.

Assembly

The machine must be fully assembled before it can be operated. Before beginning the assembly process, refer to **Needed for Setup** and gather all listed items. To ensure the assembly process goes smoothly, first clean any parts that are covered or coated in heavy-duty rust preventative (if applicable).

	<p>! WARNING HEAVY LIFT! Straining or crushing injury may occur from improperly lifting machine or some of its parts. To reduce this risk, get help from other people and use a forklift (or other lifting equipment) rated for weight of this machine.</p>
--	---

<p>NOTICE We strongly recommend using a general-purpose silicone sealant on all mating surfaces during assembly process. For those components assembled with a rubber gasket between them, apply sealant evenly on both sides of gasket before assembly.</p>



To assemble dust collector:

1. Connect (2) upper stand legs and (1) lower stand brace with (4) $\frac{5}{16}$ "-18 x $\frac{3}{4}$ " carriage bolts, $\frac{5}{16}$ " flat washers, and $\frac{5}{16}$ "-18 hex nuts (see **Figure 8**).

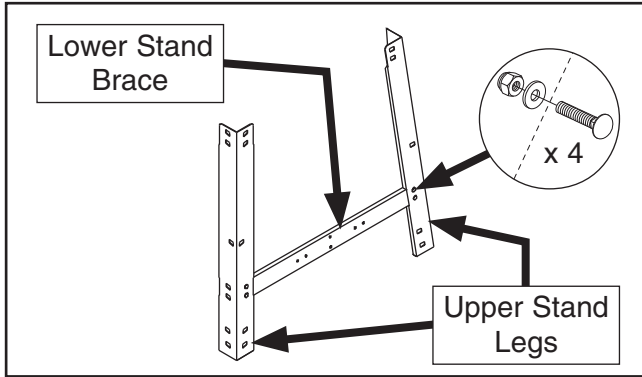

Figure 8. Upper stand legs attached to lower stand brace.

Note: To make installation of fasteners easier, use scrap wood to raise metal components off the floor.

Note: Only finger tighten hardware.

IMPORTANT: Be sure to build frame using bolt holes indicated in **Figures 8–10** and **21**. Machine will not fit correctly on frame if wrong holes are used and you will need to rebuild frame.

2. Connect same upper stand legs and (1) upper stand brace with (4) $\frac{5}{16}$ "-18 x $\frac{3}{4}$ " carriage bolts, $\frac{5}{16}$ " flat washers, and $\frac{5}{16}$ "-18 hex nuts (see **Figure 9**).

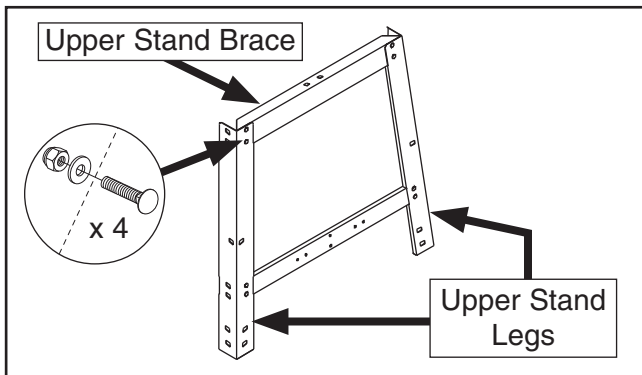

Figure 9. One side of upper stand assembled.

3. Repeat **Steps 1–2** to assemble other side of upper stand.

4. Connect both sides of upper stand, (2) upper stand braces, and (2) lower stand braces with (16) $\frac{5}{16}$ "-18 x $\frac{3}{4}$ " carriage bolts, $\frac{5}{16}$ " flat washers, and $\frac{5}{16}$ "-18 hex nuts (see **Figure 10**).

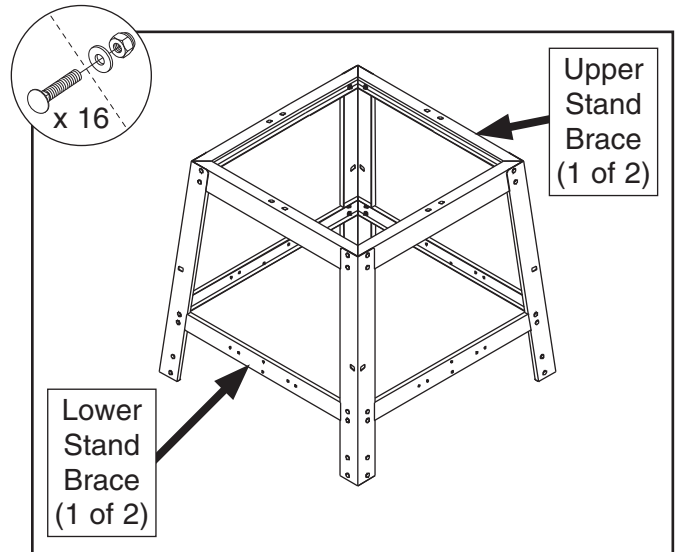

Figure 10. Stand assembled without lower legs.

5. Place level across corners of lower stand braces and square stand, then fully tighten all fasteners (see **Figure 11**).

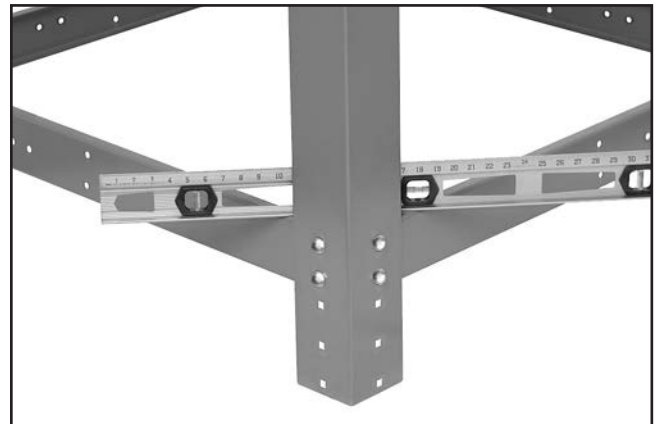

Figure 11. Level positioned on the upper stand.



- Place intake cylinder on floor and apply 3 x 6 x 1800mm foam tape to intake cylinder top rim, between mounting holes and inside edge (see **Figure 12**).

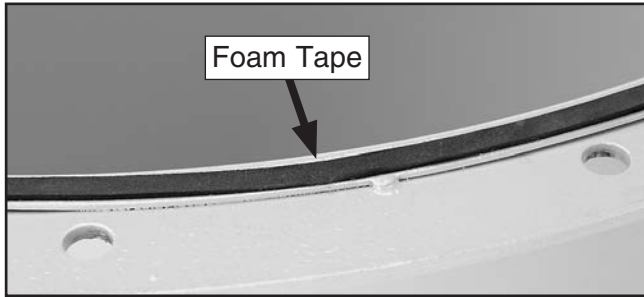

Figure 12. Foam tape applied to intake cylinder rim.

- With assistance and power lifting equipment, keep intake cylinder on floor and lower blower housing over top of intake cylinder.
- Secure intake cylinder to bottom of blower housing with (6) $\frac{5}{16}$ "-18 x $\frac{3}{4}$ " hex bolts and $\frac{5}{16}$ " flat washers to (see **Figure 13**).

Note: *This part of dust collector is not accessible after assembly, so consider using thread locker on bolts that secure intake cylinder to motor/blower housing assembly to ensure fasteners will not come loose with vibration.*

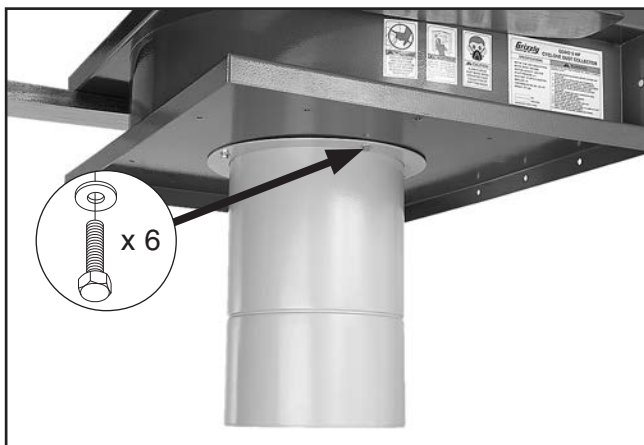

Figure 13. Intake cylinder mounted to blower housing.

- Position large cyclone funnel so smaller end rests on floor.
- Apply rubber gasket to top mating surface of large cyclone funnel.

- With assistance, place intake barrel over large cyclone funnel and align mounting holes as illustrated in **Figure 14**.

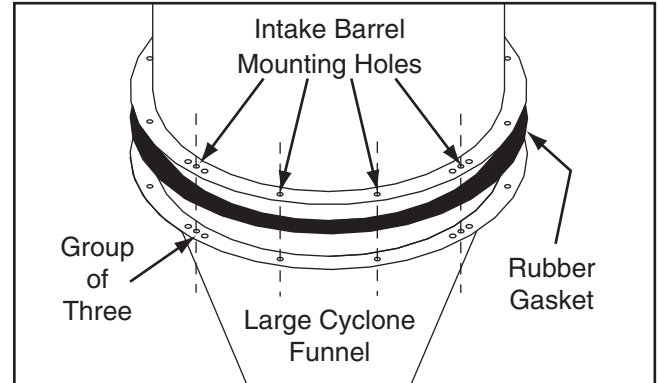

Figure 14. Intake barrel and large cyclone funnel mounting holes aligned.

NOTICE

When connecting parts that have gasket applied to mounting surface, always tighten fasteners in opposing star pattern to ensure gasket does not become crimped and compromise seal.

- Connect intake barrel and large cyclone funnel with (12) $\frac{5}{16}$ "-18 x $\frac{1}{4}$ " hex bolts, (24) $\frac{5}{16}$ " flat washers, and (12) $\frac{5}{16}$ "-18 hex nuts in mounting holes—excluding left and right holes in groups of three (see **Figure 15**).

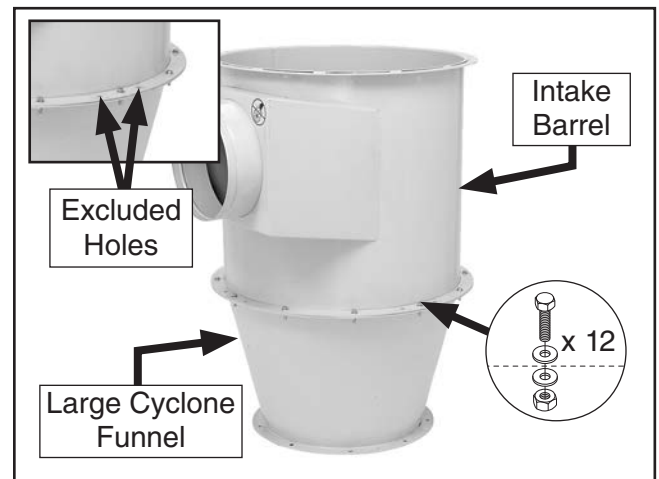

Figure 15. Intake barrel and large cyclone funnel.



13. Install (4) cyclone mounting brackets with (8) $\frac{3}{8}$ "-16 x $1\frac{1}{4}$ " hex bolts, (16) $\frac{3}{8}$ " flat washers, and (8) $\frac{3}{8}$ "-16 lock nuts (see **Figure 16**).

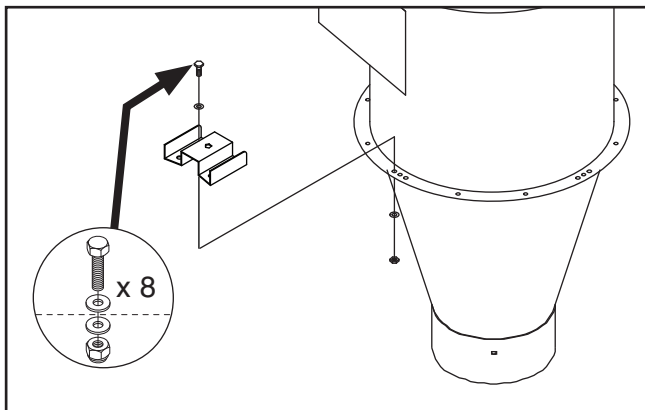

Figure 16. Cyclone mounting bracket mounted to collector assembly.

Note: Before attaching hardware in this step, separate $\frac{3}{8}$ " flat washers into two piles: one for thin and one for thick. Do not use thin washers until specified in **Step 53**.

14. Apply rubber gasket to top mating surface of intake barrel assembly.
15. With intake barrel assembly on floor, lower blower housing assembly until it is about one inch away from intake barrel assembly.

16. Using two punches or Phillips screwdrivers as alignment guides (see **Figure 17**), lower blower housing assembly onto intake barrel assembly.

Note: Orient both assemblies so that large, round intake port of intake barrel is NOT directly underneath rectangular outlet port of blower housing (see **Figure 17**). Outlet port connects to canister filters and will not allow room for attachment of intake ducting to intake port.

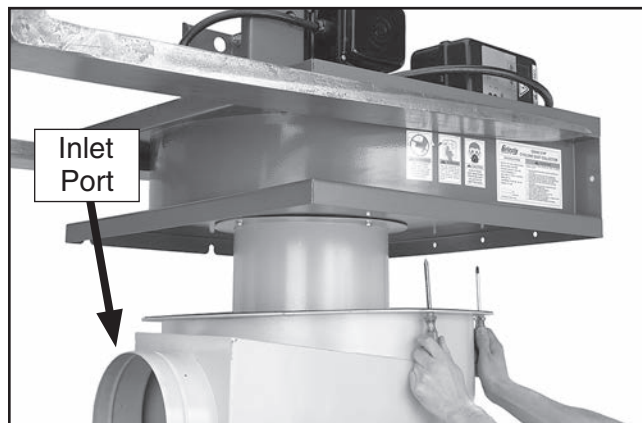

Figure 17. Aligning mounting holes.

17. Attach assemblies with (12) $\frac{5}{16}$ "-18 x $\frac{3}{4}$ " hex bolts and $\frac{5}{16}$ " flat washers (see **Figure 18**).

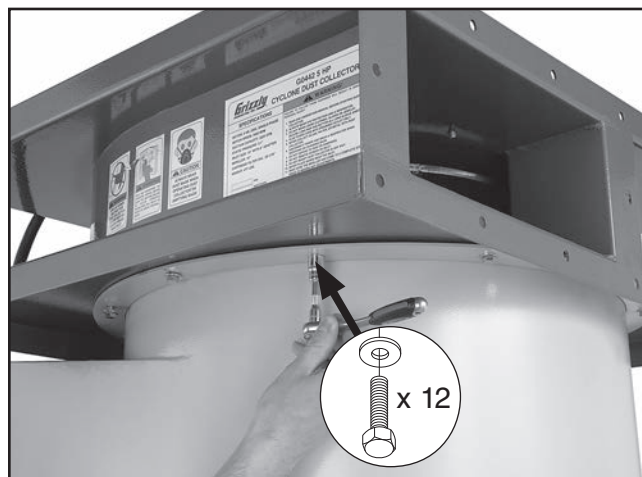

Figure 18. Securing intake barrel assembly to blower housing assembly.

Tip: When installing two bolts above intake port of intake barrel, use duct tape on bottom of wrench. This will hold bolts in wrench while inserting in place.



18. Attach vacuum port to cyclone funnel with (4) $\frac{5}{16}$ "-18 x $\frac{3}{4}$ " hex bolts and $\frac{5}{16}$ " flat washers (see **Figure 19**).
19. Attach vacuum hose to cyclone vacuum port (see **Figure 19**), and secure with vacuum hose clamp.

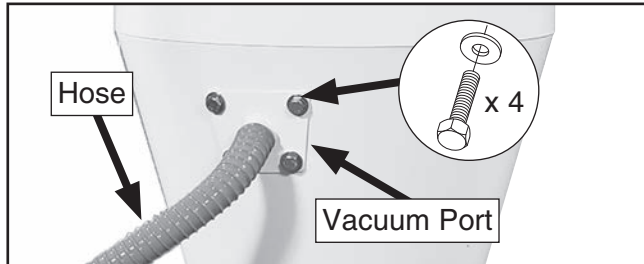

Figure 19. Cyclone vacuum tube and hose attachment.

20. Lower blower/intake assembly into upper stand assembly so that cyclone mounting brackets align with mounting holes of upper stand braces (see **Figure 20**).
21. Secure mounting brackets to upper stand with (8) $\frac{5}{16}$ "-18 x $\frac{3}{4}$ " carriage bolts, $\frac{5}{16}$ " flat washers, and $\frac{5}{16}$ "-18 hex nuts (see **Figure 20**).

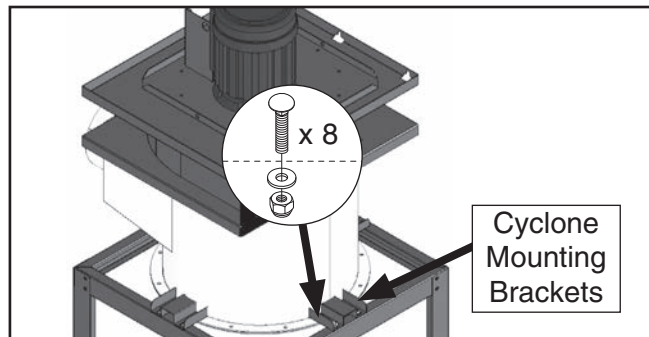

Figure 20. Blower/intake assembly attached to upper stand.

	<p>⚠ WARNING HEAVY LIFT! Straining or crushing injury may occur from improperly lifting machine or some of its parts. To reduce this risk, get help from other people and use a forklift (or other lifting equipment) rated for weight of this machine.</p>
--	---

22. With assistance and power lifting equipment, raise entire assembly high enough to install lower stand legs to bottom of stand with (16) $\frac{5}{16}$ "-18 x $\frac{3}{4}$ " carriage bolts, $\frac{5}{16}$ " flat washers, and $\frac{5}{16}$ "-18 hex nuts (see **Figure 21**).

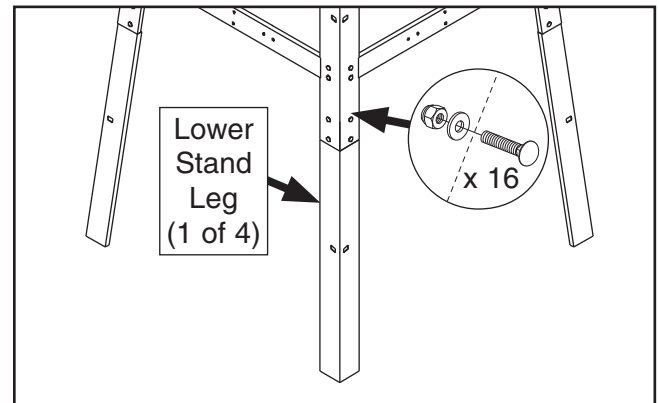

Figure 21. Lower stand legs attached.

23. Remove power lifting equipment from assembly.

Note: You will not use power lifting equipment again until moving dust collection system into its permanent position when assembly is complete.

24. Apply rubber gasket to larger, top end of small cyclone funnel.
25. Attach small cyclone funnel to bottom of large cyclone funnel with (9) $\frac{5}{16}$ "-18 x $1\frac{1}{4}$ " hex bolts, (18) $\frac{5}{16}$ " flat washers, and (9) $\frac{5}{16}$ "-18 hex nuts (see **Figure 22**).

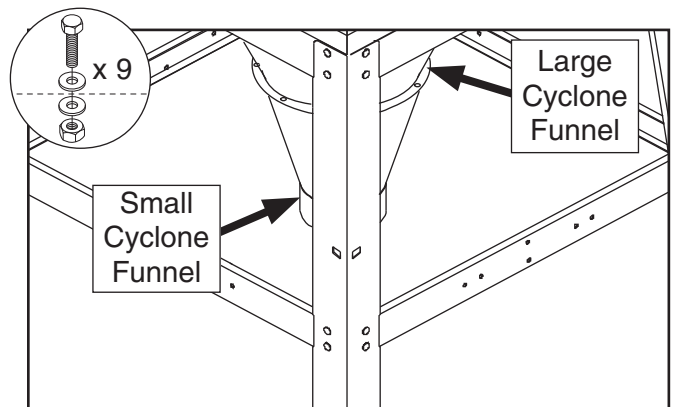

Figure 22. Small cyclone funnel and funnel port attached.



26. Position rubber gasket around opening on blower housing (see **Figure 23**).

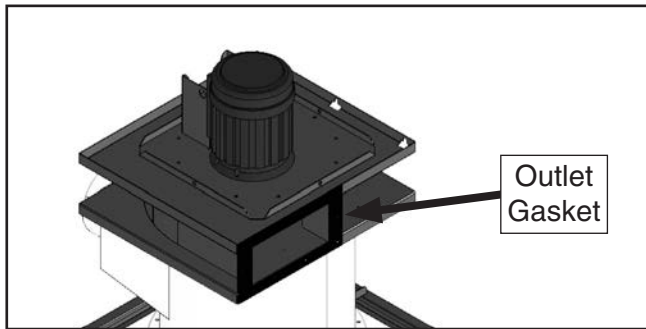

Figure 23. Outlet gasket positioned on blower housing opening.

27. Attach outlet port to blower housing with (4) $\frac{5}{16}$ "-18 x 1" hex bolts, (8) $\frac{5}{16}$ " flat washers, and (4) $\frac{5}{16}$ "-18 hex nuts (see **Figure 24**).

28. Attach filter L-braces to either side of outlet port on blower housing with (6) $\frac{5}{16}$ "-18 x 1" hex bolts, (12) $\frac{5}{16}$ " flat washers, and (6) $\frac{5}{16}$ "-18 hex nuts (see **Figure 24**).

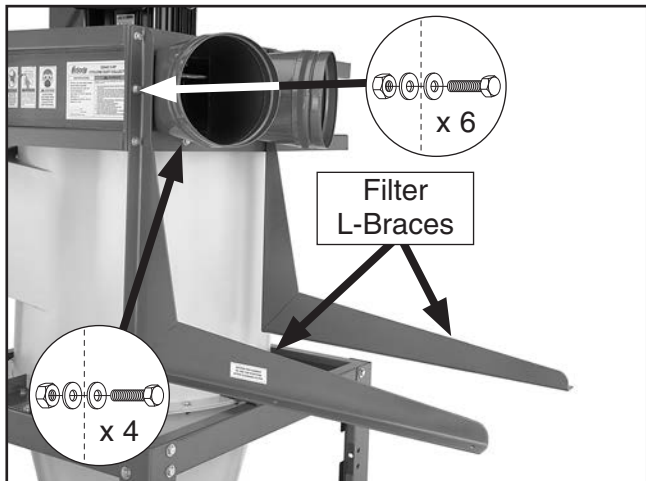

Figure 24. Filter L-braces mounted to blower housing.

29. Secure short filter brace support to back of filter L-braces with (2) $\frac{3}{8}$ "-16 x $\frac{3}{4}$ " hex bolts, (4) $\frac{3}{8}$ " flat washers, and (2) $\frac{3}{8}$ "-16 hex nuts (see **Figure 25**).

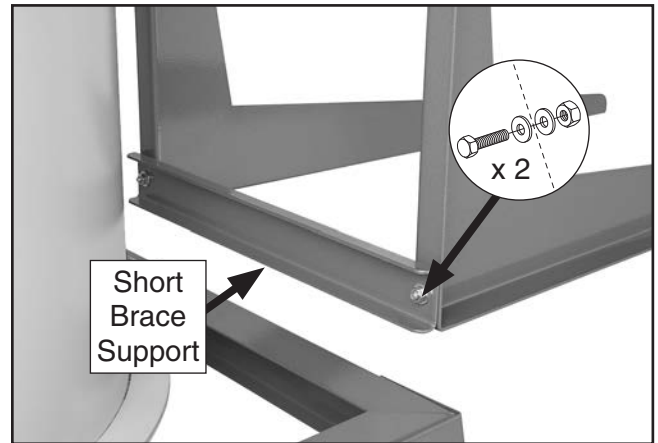

Figure 25. Short filter brace support attached.

30. Attach two long brace supports to filter braces with (4) $\frac{3}{8}$ "-16 x $\frac{3}{4}$ " hex bolts, (8) $\frac{3}{8}$ " flat washers, and (4) $\frac{3}{8}$ "-16 hex nuts, as shown in **Figure 26**.

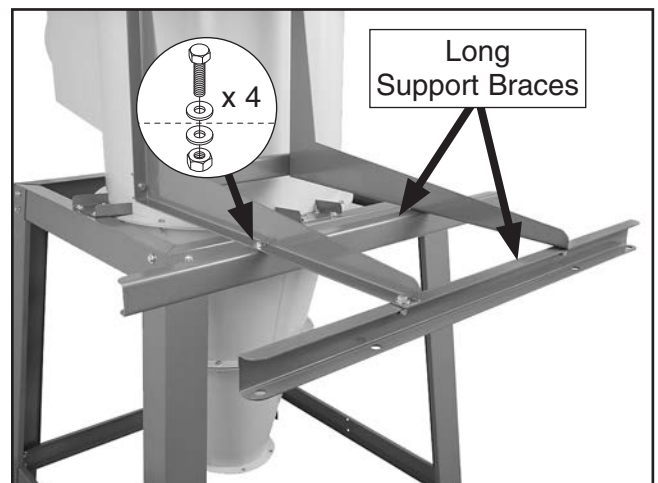

Figure 26. Long brace supports attached.



31. With assistance, position rubber mounting gaskets between filter canisters and long brace supports, and secure canisters with (8) $\frac{5}{16}$ "-18 x $\frac{3}{4}$ " hex bolts and (8) $\frac{5}{16}$ " fender washers (see **Figure 27**).

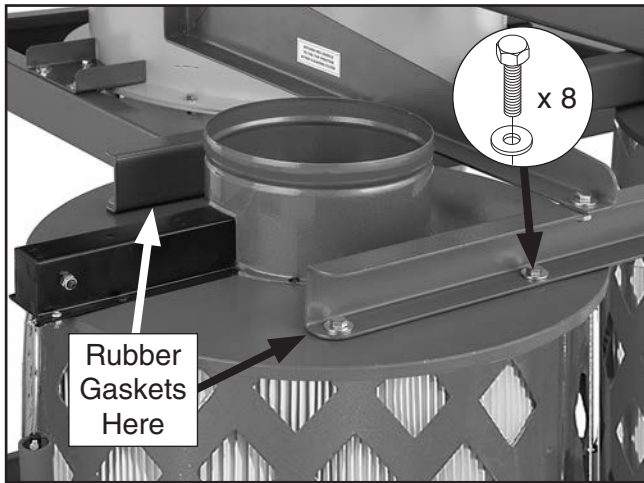

Figure 27. Canister filters mounted to the long support braces.

32. Apply (6) 3 x 15 x 700mm gaskets to upper rim of canister filter assemblies and both rims of noise mufflers.
33. Apply (2) 3 x 15 x 700mm gasket to outer circular rims of each outlet port.
34. Assemble 8" x 31 $\frac{1}{2}$ " flexible ducts, noise mufflers, and 8" x 4 $\frac{3}{4}$ " flexible ducts with 8" duct clamps (see **Figure 28**).

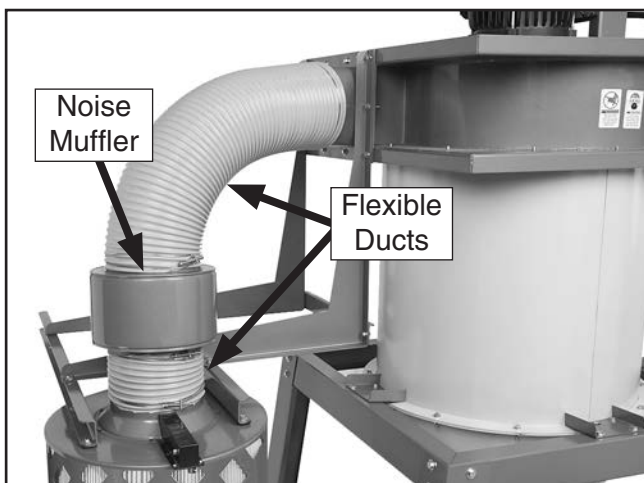

Figure 28. Ducting and noise muffler connected between blower housing and filter canister.

35. Use 8" duct clamps to connect duct assemblies between outlet port of blower housing and canister filters.
36. Fit smaller plastic collection bags over bottom of filters and clamp them in place with metal bag clamps, as shown in **Figure 29**.



Figure 29. Canister filter collection bag installed.

37. Attach front drum panel to right drum panel with (4) $\frac{5}{16}$ "-18 x $\frac{3}{4}$ " hex bolts, (8) $\frac{5}{16}$ " flat washers, and (4) $\frac{5}{16}$ "-18 hex nuts (see **Figure 30**).

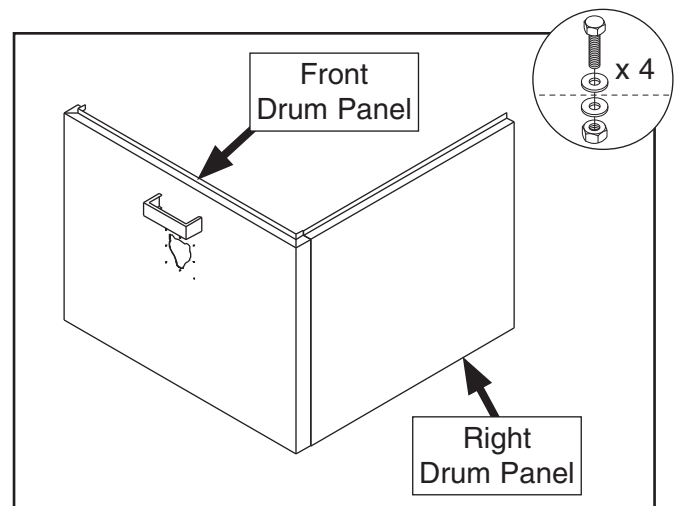

Figure 30. Front drum panel attached to right drum panel.



38. Attach collection drum vacuum port to back of rear drum panel with (4) $\frac{5}{16}$ "-18 x $\frac{3}{4}$ " hex bolts and $\frac{5}{16}$ " flat washers (see **Figure 31**).

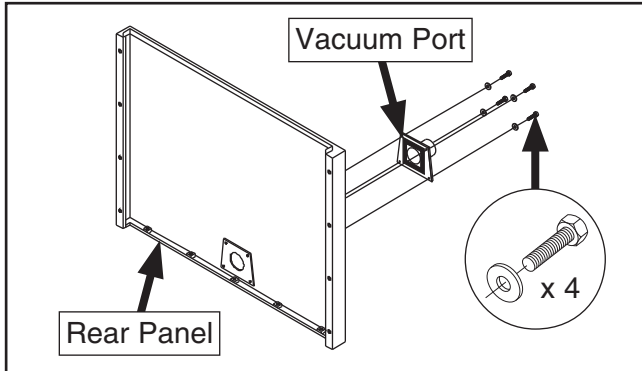

Figure 31. Vacuum port attached to rear drum panel.

39. Repeat **Step 37** with left and rear panels.

40. Attach front-right drum panel assembly to left-rear drum panel assembly with (8) $\frac{5}{16}$ "-18 x $\frac{3}{4}$ " hex bolts, (16) $\frac{5}{16}$ " flat washers, and (8) $\frac{5}{16}$ "-18 hex nuts (see **Figure 32**).

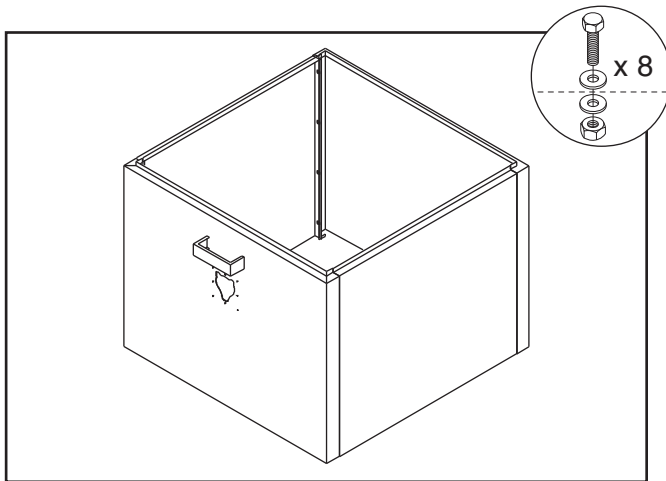

Figure 32. Side panels of drum assembly attached.

41. Turn assembly upside-down and attach base drum panel (see **Figure 33**) with (20) $\frac{5}{16}$ "-18 x $\frac{3}{4}$ " hex bolts and $\frac{5}{16}$ " flat washers.

42. Attach (4) casters to base panel with (16) $\frac{5}{16}$ "-18 x $\frac{3}{4}$ " hex bolts and $\frac{5}{16}$ " flat washers (see **Figure 33**).

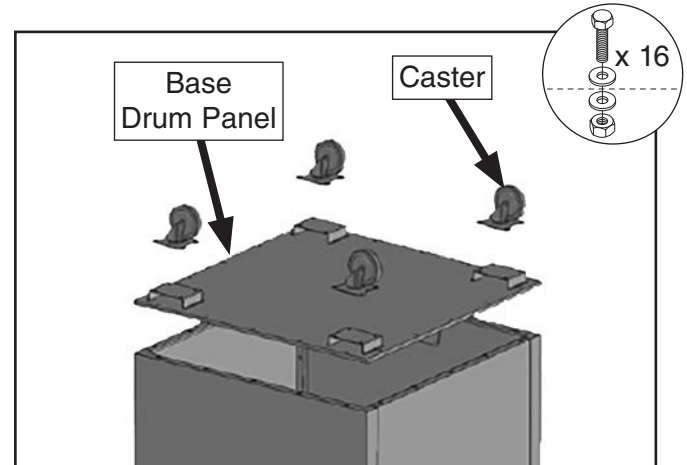

Figure 33. Attaching base drum panel and casters.

43. Turn assembly over and attach drum lid PVC rubber seal to lip of drum assembly (see **Figure 34**).

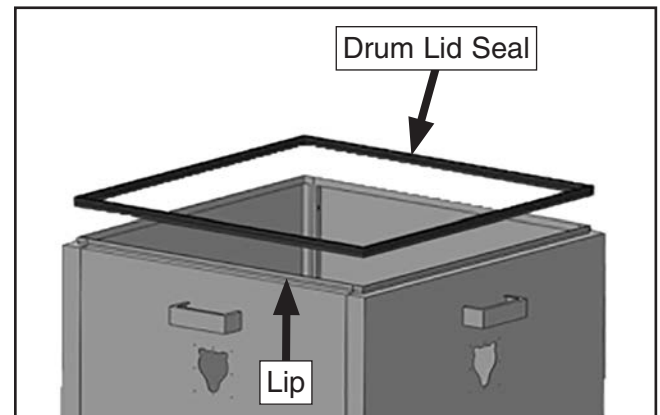

Figure 34. Attaching drum lid seal to drum assembly lip.

44. Seal inside edges and corners of drum assembly with caulk or silicone.

Note: Make sure to fully seal these edges as any missed spots or leakages will affect overall performance of dust collector.

45. Place collection drum vacuum ring on bottom of collection drum assembly once sealant is dry.



Note: During operation, this ring and vacuum connection to cyclone funnel will prevent collection bag from collapsing.

46. Install larger plastic collection bag into drum.
47. Apply (2) 5 x 50 x 2000mm foam tape rolls to inside rim of drum lid to create a seal when placed on drum.
48. Place collection drum lid on top of collection drum (see **Figure 35**).

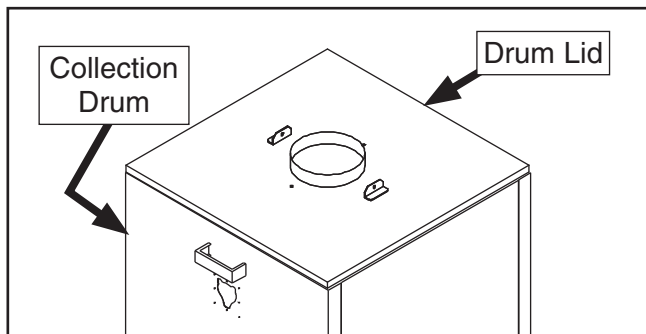

Figure 35. Drum lid placed on collection drum.

49. Position cyclone funnel adapter and drum lid together with (2) $\frac{3}{8}$ "-16 x 11" hex bolts, (2) drum lid springs, and (4) $\frac{3}{8}$ " flat washers, as shown in **Figure 36**.

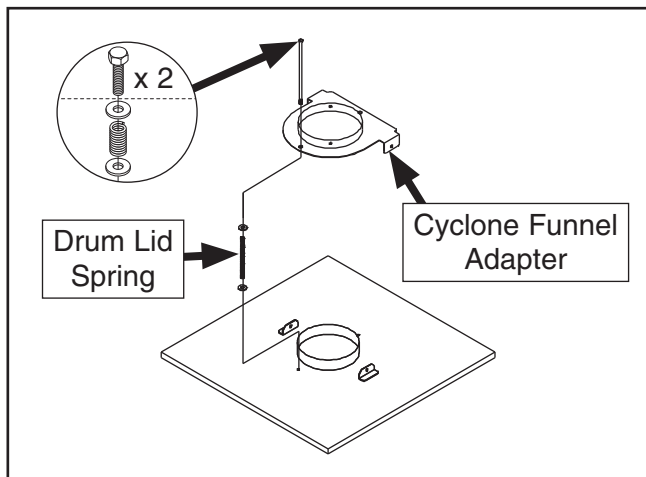

Figure 36. Installing cyclone funnel adapter.

50. Install drum lid connecting plates with (2) $\frac{3}{8}$ "-16 x 1" hex bolts, (4) $\frac{3}{8}$ " flat washers, and (2) $\frac{3}{8}$ "-16 lock nuts (see **Figure 37**).

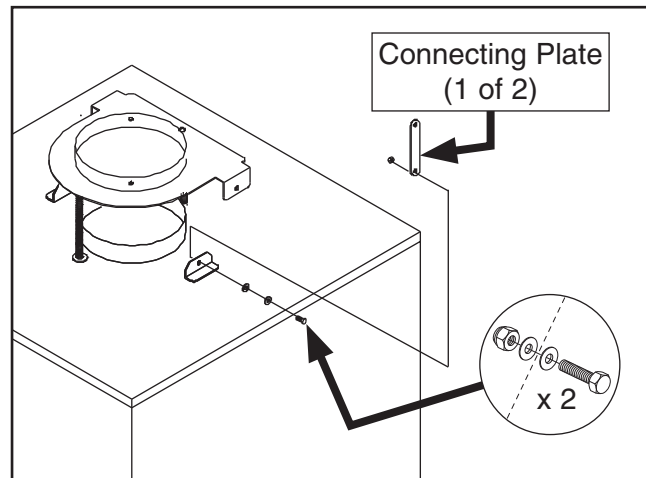

Figure 37. Installing drum lid connecting plates on drum lid.

51. Attach collection lid handle to cyclone funnel adapter and drum lid connecting plates with (4) $\frac{3}{8}$ "-16 x 1 hex bolts, (8) $\frac{3}{8}$ " flat washers, and (4) $\frac{3}{8}$ "-16 lock nuts (see **Figure 38**).

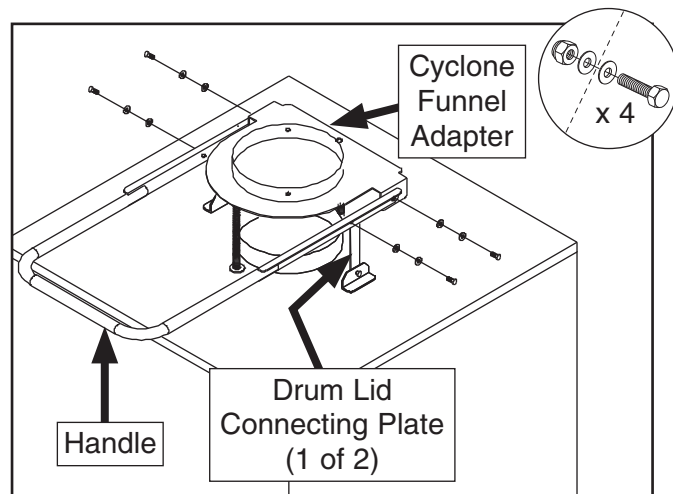

Figure 38. Collection lid handle attached to connecting plate and adapter.

52. While holding assembly in place, move collection drum assembly under cyclone assembly. Press cyclone funnel adapter and springs down to fit under small cyclone funnel.



53. Align mounting holes of small cyclone funnel and cyclone funnel adapter then attach with (4) $\frac{3}{8}$ "-16 x 1" hex bolts, (8) $\frac{3}{8}$ " thin flat washers, and (4) $\frac{3}{8}$ "-16 lock nuts (see **Figure 39**).

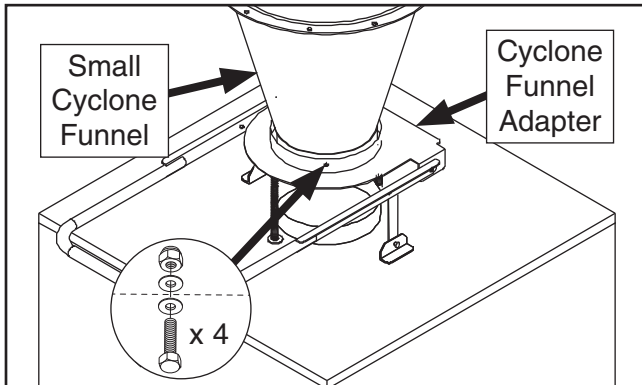

Figure 39. Small cyclone funnel attached to adapter.

54. Remove collection drum from under lid, and secure hex bolts from **Step 49** with (2) $\frac{3}{8}$ "-16 lock nuts.

IMPORTANT: DO NOT overtighten. Only tighten lock nuts until they are flush with bottom of hex bolts.

55. Move collection drum back under lid.

56. Connect drum lid to small cyclone funnel with 9" clear flexible duct and (2) 9" hose clamps (see **Figure 40**).

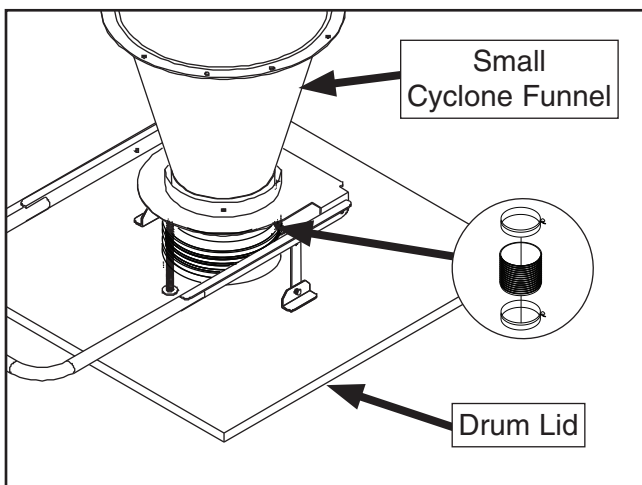

Figure 40. Cyclone funnel connected to drum lid with flexible hose (stand and drum removed for clarity).

57. Attach handle hook to lower stand brace above handle with (1) $\frac{3}{8}$ "-16 x 1" hex bolt, (2) $\frac{3}{8}$ " flat washers, and (1) $\frac{3}{8}$ "-16 lock nut (see **Figure 41**).

IMPORTANT: DO NOT tighten nut completely to allow hook to move.

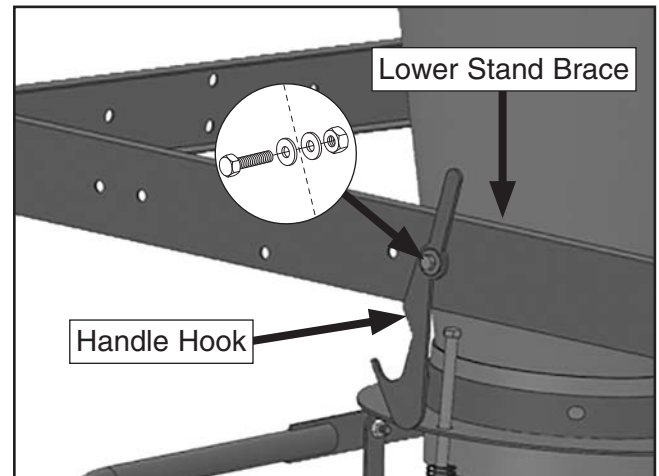

Figure 41. Handle hook attached to lower stand brace.

58. Connect other end of vacuum hose to collection drum vacuum port and secure with remaining hose clamp.

59. Secure vacuum hose inside upper and lower stand legs with (2) U-shaped clips (see **Figure 42**).



Figure 42. Securing vacuum hose to stand legs.



60. **Model G0637 only:** Mount control box onto lower stand brace with (3) $\frac{3}{8}$ "-16 x $\frac{3}{4}$ " hex bolts, (6) $\frac{3}{8}$ " flat washers, and (3) $\frac{3}{8}$ "-16 hex nuts (see **Figure 43**).

Note: Remote control uses IR (infrared) to communicate with control box, and must have direct line-of-sight to control box. Locate control box with this in mind.



Figure 43. Model G0637 control box mounted.

61. **Model G0638 only:** Mount control bracket onto lower stand brace with (2) $\frac{3}{8}$ "-16 x $\frac{3}{4}$ " hex bolts, (4) $\frac{3}{8}$ " flat washers, and (2) $\frac{3}{8}$ "-16 hex nuts (see **Figure 44**).



Figure 44. Model G0638 control box bracket mounted.

NOTICE

Use included key to unlock control box for access to complete set up.

62. **Model G0638 only:** Open control box and attach to control bracket with (4) M6-1 x 15 Phillips head screws, 6mm flat washers, and M6-1 hex nuts.

Power Connection

Before the machine can be connected to the power source, an electrical circuit and connection device must be prepared per the **POWER SUPPLY** section in this manual; and all previous setup instructions in this manual must be complete to ensure that the machine has been assembled and installed properly. The disconnect switch installed by the electrician (as recommended) is the primary means for disconnecting or connecting the machine to the power source.

Connecting to Power Source

Move the disconnect switch handle to the ON position, as illustrated below. The machine is now connected to the power source.

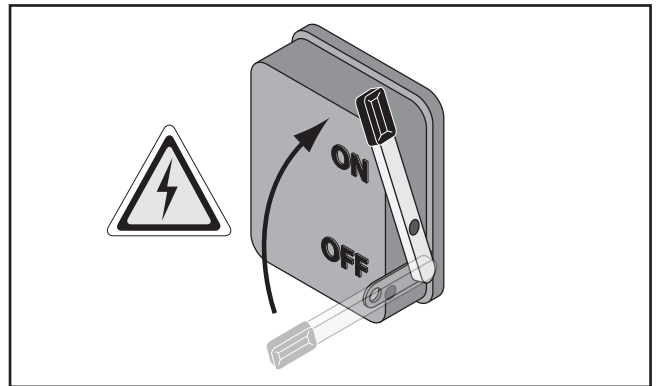

Figure 45. Connecting power to machine.

Disconnecting from Power Source

Move the disconnect switch handle to the OFF position, as illustrated below. The machine is now disconnected from the power source.

Note: Lock the switch in the OFF position to restrict others from starting the machine.

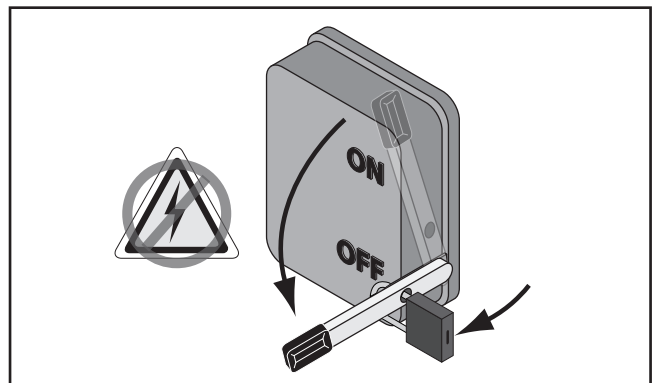

Figure 46. Disconnecting power from machine.



Grizzly **Industrial, Inc.**®

MODELS G0637 & G0638 **7½ & 10 HP CYCLONE** **DUST COLLECTORS** **OWNER'S MANUAL**

(For models manufactured since 04/12)



Model G0637



Model G0638



COPYRIGHT © MARCH, 2007 BY GRIZZLY INDUSTRIAL, INC., REVISED JANUARY, 2018 (JH)
**WARNING: NO PORTION OF THIS MANUAL MAY BE REPRODUCED IN ANY SHAPE
OR FORM WITHOUT THE WRITTEN APPROVAL OF GRIZZLY INDUSTRIAL, INC.**

#TS8762 PRINTED IN TAIWAN

V4.01.18



WARNING!

This manual provides critical safety instructions on the proper setup, operation, maintenance, and service of this machine/tool. Save this document, refer to it often, and use it to instruct other operators.

Failure to read, understand and follow the instructions in this manual may result in fire or serious personal injury—including amputation, electrocution, or death.

The owner of this machine/tool is solely responsible for its safe use. This responsibility includes but is not limited to proper installation in a safe environment, personnel training and usage authorization, proper inspection and maintenance, manual availability and comprehension, application of safety devices, cutting/sanding/grinding tool integrity, and the usage of personal protective equipment.

The manufacturer will not be held liable for injury or property damage from negligence, improper training, machine modifications or misuse.



WARNING!

Some dust created by power sanding, sawing, grinding, drilling, and other construction activities contains chemicals known to the State of California to cause cancer, birth defects or other reproductive harm. Some examples of these chemicals are:

- **Lead from lead-based paints.**
- **Crystalline silica from bricks, cement and other masonry products.**
- **Arsenic and chromium from chemically-treated lumber.**

Your risk from these exposures varies, depending on how often you do this type of work. To reduce your exposure to these chemicals: Work in a well ventilated area, and work with approved safety equipment, such as those dust masks that are specially designed to filter out microscopic particles.

Table of Contents

INTRODUCTION.....	2	Decide Who Will Design.....	37
Manual Accuracy	2	Sketch Your Shop Layout.....	37
Contact Info.....	2	Sketch a Basic Duct Layout	37
Machine Description	2	Determine Required CFMs.....	38
Identification.....	3	Determining Main Line Duct Size.....	39
Glossary Of Terms.....	4	Determining Branch Line Duct Size	39
G0637 Machine Data Sheet	5	Planning Drop Downs.....	40
G0638 Machine Data Sheet	7	Calculating Duct Resistance	40
SECTION 1: SAFETY.....	9	Example Materials List	42
Safety Instructions for Machinery	9	System Grounding	43
Additional Safety for Dust Collectors	11	SECTION 5: ACCESSORIES.....	44
SECTION 2: POWER SUPPLY	12	SECTION 6: OPERATIONS	46
Availability.....	12	Operation Safety	46
Full-Load Current Rating	12	General	46
Circuit Information	12	Remote Control.....	46
Circuit Requirements for 220V	12	SECTION 7: MAINTENANCE.....	47
Circuit Requirements for 440V	12	Schedule	47
Connection Type	13	Emptying Drums	47
Grounding Instructions	13	Cleaning Filters.....	47
Extension Cords	13	Rinsing Filter	48
Phase Converter.....	13	Removing/Replacing Filter.....	48
Model G0637 440V Conversion	14	SECTION 8: SERVICE	50
Model G0638 440V Conversion	15	Troubleshooting	50
Correcting Phase Polarity.....	16	Motor & Electrical	50
SECTION 3: SETUP	17	Dust Collector Operation	51
Needed for Setup.....	17	SECTION 9: WIRING.....	52
Unpacking	17	Wiring Safety Instructions	52
Inventory	18	G0637 Electrical Components	53
Site Considerations.....	20	G0637 Control Box Wiring Diagram	54
Mounting to Shop Floor	21	G0637 440V Wiring Diagram.....	55
Bolting to Concrete Floors.....	21	G0637 Motor Wiring Diagram.....	56
Assembly	21	G0638 Electrical Components	57
Power Connection.....	31	G0638 Control Box Wiring Diagram	58
G0637 Power Connection	32	G0638 Motor Wiring Diagram.....	59
G0638 Power Connection	32	SECTION 10: PARTS.....	60
Test Run	33	WARRANTY AND RETURNS	66
SECTION 4: DESIGNING THE SYSTEM.....	35		
General	35		
Duct Material.....	35		
Metal Duct	36		
Flexible Duct.....	36		
System Design.....	37		

INTRODUCTION

Manual Accuracy

We are proud to offer this manual with your new machine! We've made every effort to be exact with the instructions, specifications, drawings, and photographs of the machine we used when writing this manual. However, sometimes we still make an occasional mistake.

Also, owing to our policy of continuous improvement, **your machine may not exactly match the manual**. If you find this to be the case, and the difference between the manual and machine leaves you in doubt, check our website for the latest manual update or call technical support for help.

Before calling, find the manufacture date of your machine by looking at the date stamped into the machine ID label (see below). This will help us determine if the manual version you received matches the manufacture date of your machine.

Grizzly Industrial		MODEL GXXXX MACHINE NAME
SPECIFICATIONS	WARNING!	
Motor: Specification: Specification: Specification: Weight: Date Serial Number Manufactured for Grizzly in Taiwan	ing this machine: operation. s and respirator. sted/setup and suit before starting. 4. make sure the motor has stopped and disconnect power before adjustments, maintenance, or service. 5. DO NOT expose to rain or dampness. 6. DO NOT modify this machine in any way. 7. DO NOT remove safety guards. 8. Never leave machine running unattended. 9. DO NOT operate under the influence of drugs or alcohol. 10. Maintain machine carefully to prevent accidents.	

For your convenience, we post all available manuals and manual updates for free on our website at www.grizzly.com. Any updates to your model of machine will be reflected in these documents as soon as they are complete.

Contact Info

We stand behind our machines! If you have questions or need help, contact us with the information below. Before contacting, make sure you get the **serial number** and **manufacture date** from the machine ID label. This will help us help you faster.

Grizzly Technical Support
1815 W. Battlefield
Springfield, MO 65807
Phone: (570) 546-9663
Email: techsupport@grizzly.com

We want your feedback on this manual. What did you like about it? Where could it be improved? Please take a few minutes to give us feedback.

Grizzly Documentation Manager
P.O. Box 2069
Bellingham, WA 98227-2069
Email: manuals@grizzly.com

Machine Description

The Model G0637/G0638 is a 2-stage cyclone wood dust collector capable of collecting dust from multiple machines running simultaneously.

Cyclonic action separates the heavy dust and chips from the fine particles and drops them into the steel collection drum. Any remaining fine dust travels past the impeller and is trapped by the pleated cartridge filter made of spun-bond polyester. With the use of the cable and pulley system on the outside of the filter assembly, the caked dust is forced down into the collection bag.

The machine is controlled directly by the magnetic switch mounted to it or by the IR remote switch—each control includes timer options.



Identification

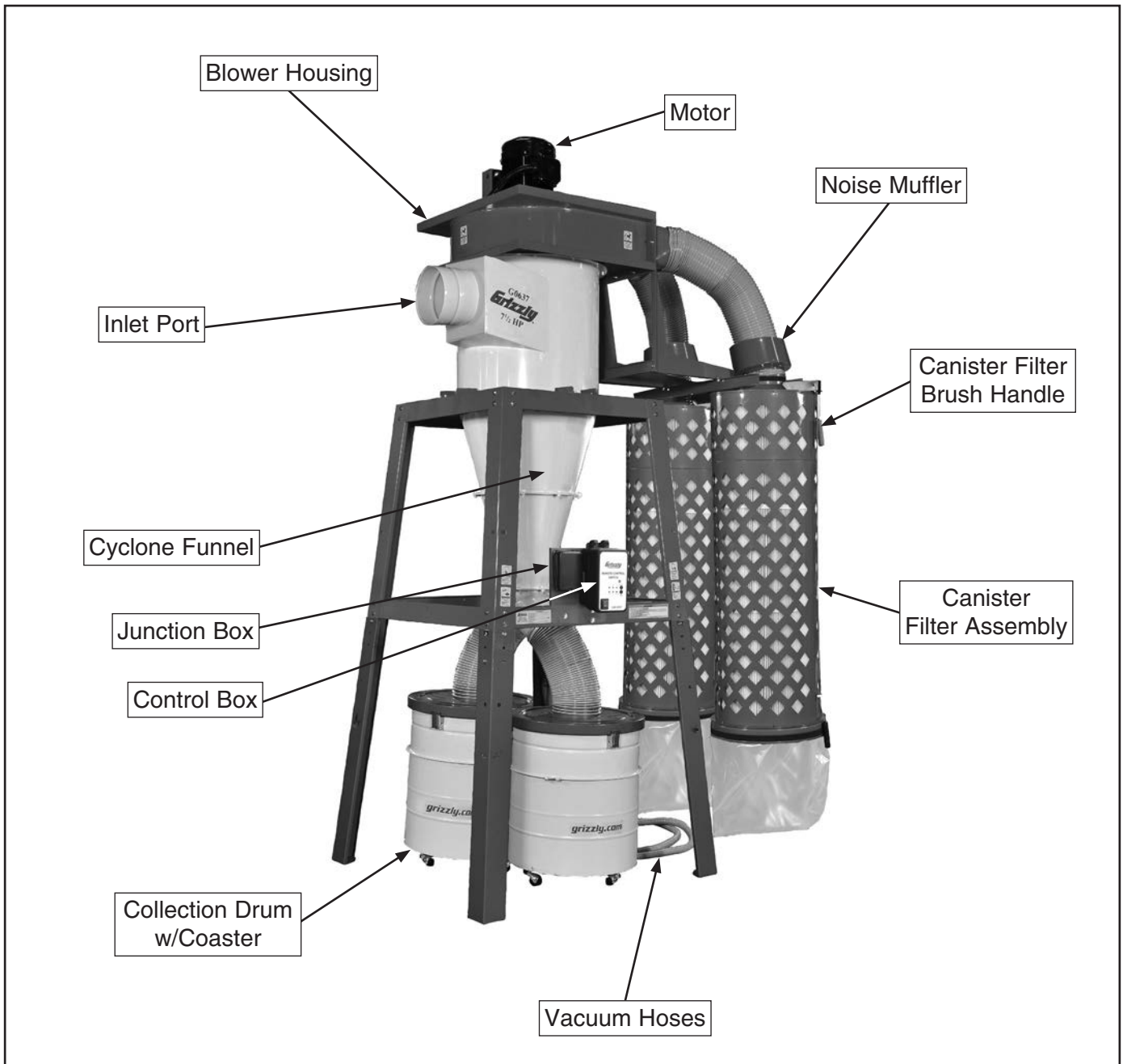

Figure 1. Identification (Model G0637 shown).

	<p>⚠ WARNING</p> <p>To reduce your risk of serious injury, read this entire manual BEFORE using machine.</p>
---	--



Glossary Of Terms

The following is a list of common definitions, terms and phrases that relate to dust collection and dust collectors in general. To get the most out of this manual, familiarize yourself with these terms before reading.

Air Suction Capacity: The maximum volume of air (rated in CFM) that a dust collector can move, at the inlet, when fully assembled and not connected to any ducting.

Branch Line: A secondary length of duct that connects a dust-producing machine to the *Main Line* of a permanent dust collection system. The minimum recommended *Velocity* for branch lines is 4000 FPM.

Collection Bag/Drum: The part of the dust collector that holds the majority of captured dust.

CFM (Cubic Feet per Minute): A measurement describing the volume of air that moves through an area in one minute. $CFM = Velocity (FPM) \times Cross\text{-}Sectional\ Area\ of\ Duct (ft.^2)$.

Cyclone: A type of two-stage dust collector that uses centrifugal force to remove large dust particles before they can reach the filter.

Duct (Ducting): Metal/plastic pipe or hose that connects the dust collector to dust-producing machines. Typically available in rigid or flexible options.

Dust Collection System: The entire assembly of dust collector, duct, and fittings used to capture dust from machines.

Dust Port/Hood: The part of a dust-producing machine that connects to dust collection duct.

Filter: The part of the dust collector that prevents the majority of suctioned dust from returning to the shop environment. Filters are rated by the size of fine dust (measured in microns) that can pass through them.

Fittings (Y's, T's, Elbows, etc.): The various duct connections that allow the branch and main lines of a dust collection system to be routed from the machine to the dust collector.

Duct Grounding: A method of using bare wire with plastic duct to safely dissipate static electricity buildup during operation.

Main Line: The primary length of duct that connects the dust collector to the branch lines of a permanent dust collection system. The minimum recommended *Velocity* for main lines is 3500 FPM.

Machine CFM Requirement: Indicates the minimum amount of airflow required at the dust port/hood of a dust-producing machine for adequate removal of the waste produced. Essentially, the performance required by the *Dust Collection System* after accounting for the drop in CFM from the static pressure loss of the duct line between the machine and the dust collector.

Powered Air Filter: An independently operated machine that removes fine dust suspended in the air. Typically operated during and after dust-producing operations as a secondary method to improve the air quality in a shop.

Single-Stage Collector: A type of dust collector where all collected chips and dust are expelled directly into the filter.

Static Pressure: Expressed in units of inches of water, this describes the difference in pressure between the air inside and outside the dust collector. It is a measure of the suction created by the blower.

Two-Stage Collector: A type of dust collector where large/heavy waste is captured in a separate container before the airflow reaches the filter. Benefits include longer operation times between filter maintenance or replacement.

Velocity: The speed of airflow movement, measured in FPM (Feet Per Minute). $Velocity = Volume (CFM) / Cross\text{-}Sectional\ Area\ of\ Duct (ft.^2)$.





MACHINE DATA SHEET

Customer Service #: (570) 546-9663 · To Order Call: (800) 523-4777 · Fax #: (800) 438-5901

MODEL G0637 7-1/2 HP 3-PHASE CYCLONE DUST COLLECTOR

Product Dimensions:

Weight..... 818 lbs.
Width (side-to-side) x Depth (front-to-back) x Height..... 76-3/4 x 60 x 139-3/8 in.
Footprint (Length x Width)..... 77 x 64 in.

Shipping Dimensions:

Carton #1

Type..... Wood Crate
Content..... Machine
Weight..... 886 lbs.
Length x Width x Height..... 90 x 39 x 42 in.
Must Ship Upright..... Yes

Carton #2

Type..... Cardboard Box
Content..... Canister Filter #1
Weight..... 57 lbs.
Length x Width x Height..... 57 x 23 x 23 in.
Must Ship Upright..... No

Carton #3

Type..... Cardboard Box
Content..... Canister Filter #2
Weight..... 57 lbs.
Length x Width x Height..... 57 x 23 x 23 in.
Must Ship Upright..... No

Electrical:

Power Requirement..... 220V or 440V, 3-Phase, 60 Hz
Prewired Voltage..... 220V
Full-Load Current Rating..... 25A at 220V, 12.5A at 440V
Minimum Circuit Size..... 50A at 220V, 20A at 440V
Connection Type..... Permanent (Hardwire to Shutoff Switch)
Switch Type..... Remote Control Magnetic Switch w/Overload Protection
Voltage Conversion Kit..... P0637119V2 for 440V
Recommended Phase Converter..... G5845

Motors:

Main

Horsepower..... 7.5 HP
Phase..... 3-Phase
Amps..... 25A/12.5A
Speed..... 3450 RPM
Type..... TEFC Induction (Class F)
Power Transfer Direct Drive
Bearings..... Shielded & Permanently Lubricated



Main Specifications:

Operation

Dust Collector Type..... Two-Stage (Cyclone)
Approved Dust Types..... Wood
Filter Type..... Pleated Cartridge
Airflow Capacity..... 3468 CFM @ 4.3 in. SP
Max Static Pressure (at 0 CFM)..... 14.73 in.
Main Inlet Size..... 10 in.
Inlet Adapter Included..... No
Machine Collection Capacity At One Time..... 4
Maximum Material Collection Capacity..... 20 cu. ft.
Filtration Rating..... 0.2 – 2 Micron
Filter Surface Area..... 261 sq. ft.

Bag Information

No of Lower Bags..... 2
Lower Bag Diameter..... 22-7/16 in.
Lower Bag Length..... 26-3/4 in.

Canister Information

No of Canister Filters..... 2
Canister Filter Diameter..... 19-11/16 in.
Canister Filter Length..... 47-1/4 in.
Collection Drum Size..... 55 Gallons

Impeller Information

Impeller Type..... Radial Fin
Impeller Size..... 18 in.
Impeller Blade Thickness..... 3/8 in.

Construction

Lower Bag..... Clear Plastic
Canister..... Spun Bond Polyester
Frame..... Steel Sheet Metal (13 ga.)
Impeller..... Steel
Paint..... Powder Coated
Blower Housing..... 11 Gauge Steel
Body..... 16 Gauge Steel
Collection Drum..... Steel

Other Specifications:

Country Of Origin Taiwan
Warranty 1 Year
Approximate Assembly & Setup Time 3 Hours
Serial Number Location ID Label on Machine
Sound Rating 84 – 88 dB
ISO 9001 Factory Yes
CSA Certified Yes





MACHINE DATA SHEET

Customer Service #: (570) 546-9663 · To Order Call: (800) 523-4777 · Fax #: (800) 438-5901

MODEL G0638 10 HP 3-PHASE CYCLONE DUST COLLECTOR

Product Dimensions:

Weight..... 732 lbs.
Width (side-to-side) x Depth (front-to-back) x Height..... 76-3/4 x 60 x 139-3/8 in.
Footprint (Length x Width)..... 77 x 64 in.

Shipping Dimensions:

Carton #1

Type..... Wood Crate
Content..... Machine
Weight..... 789 lbs.
Length x Width x Height..... 90 x 39 x 42 in.
Must Ship Upright..... Yes

Carton #2

Type..... Cardboard Box
Content..... Canister Filter #1
Weight..... 74 lbs.
Length x Width x Height..... 68 x 23 x 23 in.
Must Ship Upright..... No

Carton #3

Type..... Cardboard Box
Content..... Canister Filter #2
Weight..... 74 lbs.
Length x Width x Height..... 68 x 23 x 23 in.
Must Ship Upright..... No

Electrical:

Power Requirement..... 220V or 440V, 3-Phase, 60 Hz
Prewired Voltage..... 220V
Full-Load Current Rating..... 30A at 220V, 15A at 440V
Minimum Circuit Size..... 50A at 220V, 20A at 440V
Connection Type..... Permanent (Hardwire to Shutoff Switch)
Switch Type..... Remote Control Magnetic Switch w/Overload Protection
Voltage Conversion Kit..... P0638119V2 for 440V
Recommended Phase Converter..... G7978

Motors:

Main

Horsepower..... 10 HP
Phase..... 3-Phase
Amps..... 30A/15A
Speed..... 3450 RPM
Type..... TEFC Induction (Class F)
Power Transfer Direct Drive
Bearings..... Shielded & Permanently Lubricated



Main Specifications:

Operation

Dust Collector Type..... Two-Stage (Cyclone)
Approved Dust Types..... Wood
Filter Type..... Pleated Cartridge
Airflow Capacity..... 4029 CFM @ 4.3 in. SP
Max Static Pressure (at 0 CFM)..... 16.8 in.
Main Inlet Size..... 12 in.
Inlet Adapter Included..... No
Machine Collection Capacity At One Time..... 4
Maximum Material Collection Capacity..... 20 cu. ft.
Filtration Rating..... 0.2 – 2 Micron
Filter Surface Area..... 398 sq. ft.

Bag Information

No of Lower Bags..... 2
Lower Bag Diameter..... 570mm
Lower Bag Length..... 680mm

Canister Information

No of Canister Filters..... 2
Canister Filter Diameter..... 19-11/16 in.
Canister Filter Length..... 59 in.
Collection Drum Size..... 55 Gallons

Impeller Information

Impeller Type..... Radial Fin
Impeller Size..... 18-1/2 in.
Impeller Blade Thickness..... 3/8 in.

Construction

Lower Bag..... Clear Plastic
Canister..... Spun Bond Polyester
Frame..... Steel Sheet Metal (13 ga.)
Impeller..... Steel
Paint..... Powder Coated
Blower Housing..... 11 Gauge Steel
Body..... 16 Gauge Steel
Collection Drum..... Steel

Other Specifications:

Country Of Origin Taiwan
Warranty 1 Year
Approximate Assembly & Setup Time 3 Hours
Serial Number Location ID Label on Machine
Sound Rating 87 – 90 dB
ISO 9001 Factory Yes
CSA Certified Yes



SECTION 1: SAFETY

For Your Own Safety, Read Instruction Manual Before Operating This Machine

The purpose of safety symbols is to attract your attention to possible hazardous conditions. This manual uses a series of symbols and signal words intended to convey the level of importance of the safety messages. The progression of symbols is described below. Remember that safety messages by themselves do not eliminate danger and are not a substitute for proper accident prevention measures. Always use common sense and good judgment.

 **DANGER** Indicates an imminently hazardous situation which, if not avoided, **WILL** result in death or serious injury.

 **WARNING** Indicates a potentially hazardous situation which, if not avoided, **COULD** result in death or serious injury.

 **CAUTION** Indicates a potentially hazardous situation which, if not avoided, **MAY** result in minor or moderate injury. It may also be used to alert against unsafe practices.

NOTICE This symbol is used to alert the user to useful information about proper operation of the machine.

Safety Instructions for Machinery

WARNING

OWNER'S MANUAL. Read and understand this owner's manual **BEFORE** using machine.

TRAINED OPERATORS ONLY. Untrained operators have a higher risk of being hurt or killed. Only allow trained/supervised people to use this machine. When machine is not being used, disconnect power, remove switch keys, or lock-out machine to prevent unauthorized use—especially around children. Make workshop kid proof!

DANGEROUS ENVIRONMENTS. Do not use machinery in areas that are wet, cluttered, or have poor lighting. Operating machinery in these areas greatly increases the risk of accidents and injury.

MENTAL ALERTNESS REQUIRED. Full mental alertness is required for safe operation of machinery. Never operate under the influence of drugs or alcohol, when tired, or when distracted.

ELECTRICAL EQUIPMENT INJURY RISKS. You can be shocked, burned, or killed by touching live electrical components or improperly grounded machinery. To reduce this risk, only allow qualified service personnel to do electrical installation or repair work, and always disconnect power before accessing or exposing electrical equipment.

DISCONNECT POWER FIRST. Always disconnect machine from power supply **BEFORE** making adjustments, changing tooling, or servicing machine. This prevents an injury risk from unintended startup or contact with live electrical components.

EYE PROTECTION. Always wear ANSI-approved safety glasses or a face shield when operating or observing machinery to reduce the risk of eye injury or blindness from flying particles. Everyday eyeglasses are not approved safety glasses.



WARNING

WEARING PROPER APPAREL. Do not wear clothing, apparel or jewelry that can become entangled in moving parts. Always tie back or cover long hair. Wear non-slip footwear to avoid accidental slips, which could cause loss of workpiece control.

HAZARDOUS DUST. Dust created while using machinery may cause cancer, birth defects, or long-term respiratory damage. Be aware of dust hazards associated with each workpiece material, and always wear a NIOSH-approved respirator to reduce your risk.

HEARING PROTECTION. Always wear hearing protection when operating or observing loud machinery. Extended exposure to this noise without hearing protection can cause permanent hearing loss.

REMOVE ADJUSTING TOOLS. Tools left on machinery can become dangerous projectiles upon startup. Never leave chuck keys, wrenches, or any other tools on machine. Always verify removal before starting!

INTENDED USAGE. Only use machine for its intended purpose and never make modifications not approved by Grizzly. Modifying machine or using it differently than intended may result in malfunction or mechanical failure that can lead to serious personal injury or death!

AWKWARD POSITIONS. Keep proper footing and balance at all times when operating machine. Do not overreach! Avoid awkward hand positions that make workpiece control difficult or increase the risk of accidental injury.

CHILDREN & BYSTANDERS. Keep children and bystanders at a safe distance from the work area. Stop using machine if they become a distraction.

GUARDS & COVERS. Guards and covers reduce accidental contact with moving parts or flying debris. Make sure they are properly installed, undamaged, and working correctly.

FORCING MACHINERY. Do not force machine. It will do the job safer and better at the rate for which it was designed.

NEVER STAND ON MACHINE. Serious injury may occur if machine is tipped or if the cutting tool is unintentionally contacted.

STABLE MACHINE. Unexpected movement during operation greatly increases risk of injury or loss of control. Before starting, verify machine is stable and mobile base (if used) is locked.

USE RECOMMENDED ACCESSORIES. Consult this owner's manual or the manufacturer for recommended accessories. Using improper accessories will increase the risk of serious injury.

UNATTENDED OPERATION. To reduce the risk of accidental injury, turn machine **OFF** and ensure all moving parts completely stop before walking away. Never leave machine running while unattended.

MAINTAIN WITH CARE. Follow all maintenance instructions and lubrication schedules to keep machine in good working condition. A machine that is improperly maintained could malfunction, leading to serious personal injury or death.

CHECK DAMAGED PARTS. Regularly inspect machine for any condition that may affect safe operation. Immediately repair or replace damaged or mis-adjusted parts before operating machine.

MAINTAIN POWER CORDS. When disconnecting cord-connected machines from power, grab and pull the plug—NOT the cord. Pulling the cord may damage the wires inside. Do not handle cord/plug with wet hands. Avoid cord damage by keeping it away from heated surfaces, high traffic areas, harsh chemicals, and wet/damp locations.

EXPERIENCING DIFFICULTIES. If at any time you experience difficulties performing the intended operation, stop using the machine! Contact our Technical Support at (570) 546-9663.



Additional Safety for Dust Collectors

WARNING

INTENDED USE. This dust collector is only intended for collecting wood dust and chips from woodworking machines. DO NOT use this dust collector to collect metal, dirt, pebbles, drywall, asbestos, lead paint, silica, liquids, aerosols, or any flammable, combustible, or hazardous materials.

HAZARDOUS DUST. Dust created while using machinery may cause cancer, birth defects, or long-term respiratory damage. Be aware of dust hazards associated with each workpiece material, and always wear a NIOSH-approved respirator to reduce your risk.

DUST ALLERGIES. Dust from certain woods may cause an allergic reaction in people and animals. Make sure you know what type of wood dust you will be exposed to in case there is a possibility of an allergic reaction.

WEAR RESPIRATOR. Fine dust that is too small to be caught in the filter will be blown into the ambient air during operation. Always wear a NIOSH approved respirator during operation and for a short time after to reduce your risk of permanent respiratory damage.

EMPTYING DUST. When emptying dust from the collection container, wear a respirator and safety glasses. Empty dust away from ignition sources and into an approved container.

DISCONNECTING POWER SUPPLY. Turn the switch **OFF**, disconnect the dust collector from the power supply, and allow the impeller to come to a complete stop before leaving the machine unattended or doing any service, cleaning, maintenance, or adjustments.

REGULAR CLEANING. Regularly check/empty the collection bags or drum to avoid the buildup of fine dust that can increase the risk of fire. Make sure to regularly clean the surrounding area where the machine is operated—excessive dust buildup on overhead lights, heaters, electrical panels, or other heat sources will increase the risk of fire.

SUSPENDED DUST PARTICLES AND IGNITION SOURCES. DO NOT operate the dust collector in areas where explosion risks are high. Areas of high risk include, but are not limited to, areas near pilot lights, open flames, or other ignition sources.

FIRE SUPPRESSION. Only operate the dust collector in locations that contain a fire suppression system or have a fire extinguisher nearby.

IMPELLER HAZARDS. DO NOT place your hands or tools near the open inlet during operation for any reason. The powerful suction could easily cause accidental contact with the impeller which will cause serious personal injury or damage to the machine. Always keep small animals and children away from open dust collection inlets.

AVOIDING SPARKS. DO NOT allow steel or rocks to strike the impeller—this may produce sparks. Sparks can smolder in wood dust for a long time before a fire is detected. If you accidentally cut into wood containing tramp metal (nails, staples, spikes, etc.), immediately turn **OFF** the dust collector, disconnect it from power, and wait for the impeller to stop—then empty the collection container into an approved airtight metal container.

OPERATING LOCATION. To reduce respiratory exposure to fine dust, locate permanently installed dust collectors away from the working area, or in another room that is equipped with a smoke detector. DO NOT operate the dust collector in rainy or wet locations—exposure to water may create a shock hazard or decrease the life of the machine.

STATIC ELECTRICITY. Plastic dust lines generate high amounts of static electricity as dust chips pass through them. Although rare, sparks caused by static electricity can cause explosions or fire. To reduce this risk, make sure all dust lines are thoroughly grounded by using a grounding wire.



SECTION 2: POWER SUPPLY

Availability

Before installing the machine, consider the availability and proximity of the required power supply circuit. If an existing circuit does not meet the requirements for this machine, a new circuit must be installed. To minimize the risk of electrocution, fire, or equipment damage, installation work and electrical wiring must be done by an electrician or qualified service personnel in accordance with all applicable codes and standards.

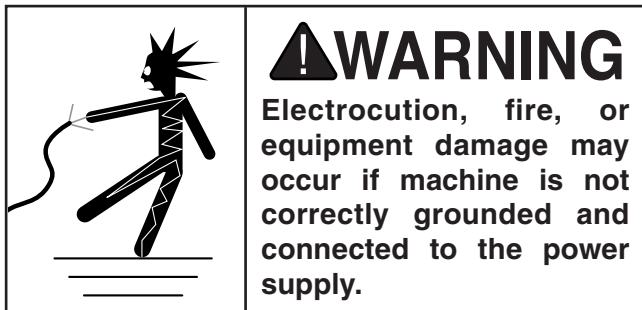

Full-Load Current Rating

The full-load current rating is the amperage a machine draws at 100% of the rated output power. On machines with multiple motors, this is the amperage drawn by the largest motor or sum of all motors and electrical devices that might operate at one time during normal operations.

Model G0637:

Full-Load Current Rating at 220V 25 Amps

Full-Load Current Rating at 440V .. 12.5 Amps

Model G0638:

Full-Load Current Rating at 220V 30 Amps

Full-Load Current Rating at 440V 15 Amps

The full-load current is not the maximum amount of amps that the machine will draw. If the machine is overloaded, it will draw additional amps beyond the full-load rating.

If the machine is overloaded for a sufficient length of time, damage, overheating, or fire may result—especially if connected to an undersized circuit. To reduce the risk of these hazards, avoid overloading the machine during operation and make sure it is connected to a power supply circuit that meets the requirements in the following section.

Circuit Information

A power supply circuit includes all electrical equipment between the breaker box or fuse panel in the building and the machine. The power supply circuit used for this machine must be sized to safely handle the full-load current drawn from the machine for an extended period of time. (If this machine is connected to a circuit protected by fuses, use a time delay fuse marked D.)

! CAUTION

For your own safety and protection of property, consult an electrician if you are unsure about wiring practices or electrical codes in your area.

Note: *The circuit requirements listed in this manual apply to a dedicated circuit—where only one machine will be running at a time. If this machine will be connected to a shared circuit where multiple machines will be running at the same time, consult a qualified electrician to ensure that the circuit is properly sized for safe operation.*

Circuit Requirements for 220V

This machine can be converted to operate on a 220V power supply (refer to **Voltage Conversion** instructions). This power supply must have a verified ground and meet the following requirements:

Nominal Voltage 220V
Cycle 60 Hz
Phase 3-Phase
Circuit Rating 50 Amps
Connection Hardwired w/Locking Switch

Circuit Requirements for 440V

This machine can be converted to operate on a 440V power supply (refer to **Voltage Conversion** instructions) that has a verified ground and meets the following requirements:

Nominal Voltage 440V
Cycle 60 Hz
Phase 3-Phase
Rated Size 20 Amps
Connection Hardwired w/Locking Switch



Connection Type

A permanently connected (hardwired) power supply is typically installed with wires running through mounted and secured conduit. A disconnecting means, such as a locking switch (see following **Figure**), must be provided to allow the machine to be disconnected (isolated) from the power supply when required. This installation must be performed by an electrician in accordance with all applicable electrical codes and ordinances.

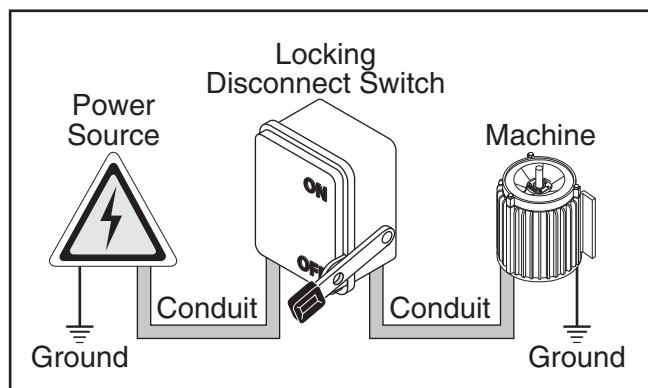

Figure 2. Typical setup of a permanently connected machine.

Grounding Instructions

In the event of a malfunction or breakdown, grounding provides a path of least resistance for electrical current to reduce the risk of electric shock. A permanently connected machine must be connected to a grounded metal permanent wiring system; or to a system having an equipment-grounding conductor. All grounds must be verified and rated for the electrical requirements of the machine. Improper grounding can increase the risk of electric shock!

!WARNING

Serious injury could occur if you connect the machine to power before completing the setup process. DO NOT connect to power until instructed later in this manual.

Extension Cords

Since this machine must be permanently connected to the power supply, an extension cord cannot be used.

Phase Converter

When using a phase converter, the power from the manufactured power leg (sometimes called the wild wire) can fluctuate. Connect the manufactured power leg to the **3L/2** terminal to prevent damage to the IC board or transformer. The wire from this terminal can handle some fluctuation because it goes directly to the motor. The power going to the **1L/2** and **5L/3** terminals goes to the IC board and transformer and must be consistent to prevent damage.



G0637 440V Conversion

The Model G0637 can be converted for 440V operation. This conversion job consists of disconnecting the machine from the power source, replacing the control box assembly and the motor cord, and rewiring the motor for 440V operation.

The necessary conversion kit (Part P0637119V2) for this procedure can be purchased by calling Grizzly Customer Service at (800) 523-4777.

All wiring changes must be inspected by a qualified electrician before the machine is connected to the power source. If you need help at any time during this procedure, call Grizzly Tech Support at (570) 546-9663.

To rewire the Model G0637 for 440V operation:

1. DISCONNECT MACHINE FROM POWER!
2. Disconnect existing incoming power and 300V motor wires from the control box (use illustration in **Figure 3** for a general reference), then replace 220V control box with 440V control box.

3. Connect four incoming power wires to the control box, as illustrated to the right.
4. Connect new 600V motor cord wires to control box, as shown in **Figure 3**.
5. Disconnect the old motor cord from the motor and remove the (3) terminal jumpers (see **Figure 4**).

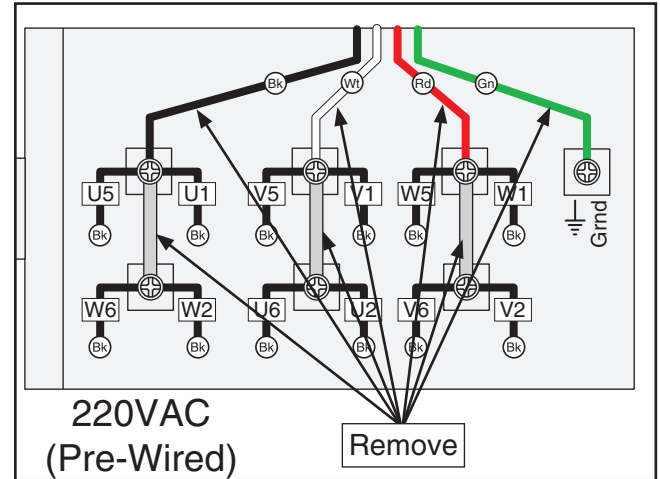

Figure 4. Model G0637 motor wired for 220V.

6. Rewire the motor wires for 440V and attach the new motor cord, as illustrated in **Figure 5**.

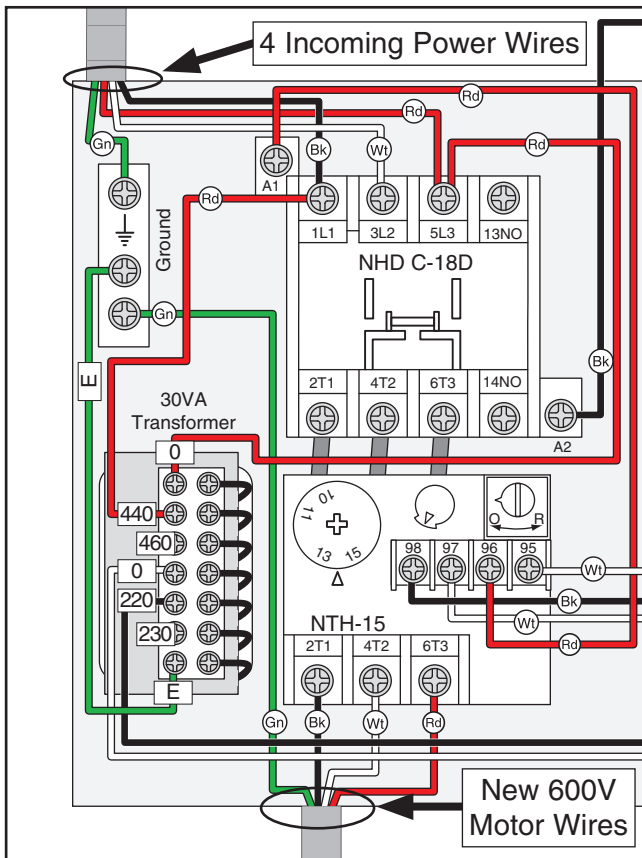

Figure 3. Model G0637 440V control box wiring.

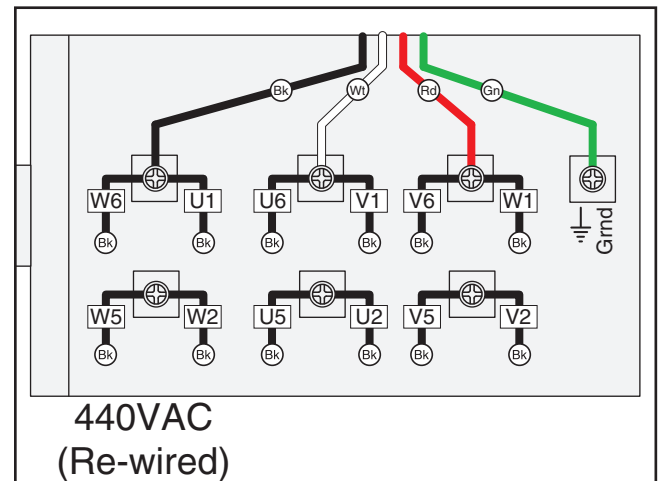

Figure 5. Model G0637 motor re-wired for 440V.



Model G0638 440V Conversion

To operate the Model G0638 on 440V power, you must purchase a G0638 440V Conversion Kit. Call our customer service number at (800) 523-4777 and order part number P0638119V2.

To convert the G0638 to 440V:

1. DISCONNECT MACHINE FROM POWER!
2. Open the control box and identify the overload relay and the transformer (see **Figure 6**).

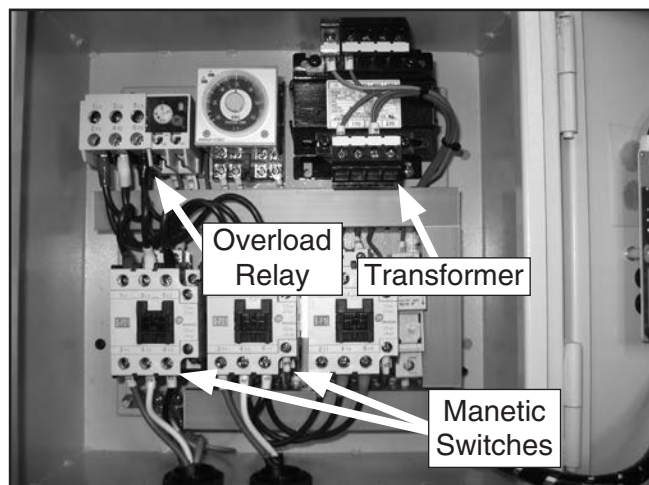

Figure 6. Model G0638 control box overload relay, magnetic switches, and transformer.

3. Replace the overload relay with the one included in the conversion kit, and turn the AMP dial to 15.
4. Move the "R0" wire on the transformer from the 220V terminal to the 440V terminal (see **Figure 7**).

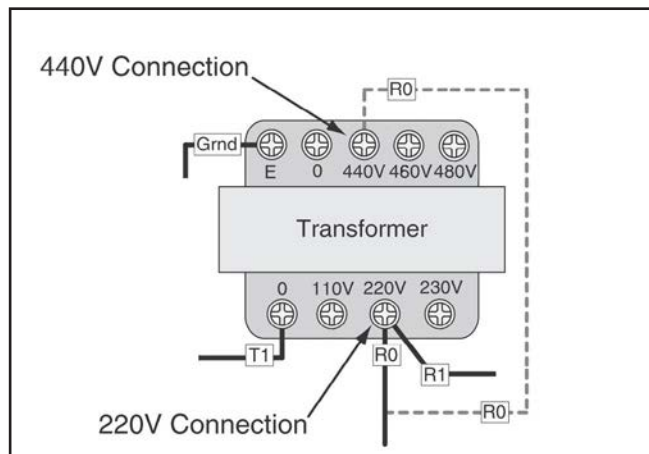

Figure 7. Model G0638 220V and 440V transformer connections.

5. Remove the motor cords from the two magnetic switch assemblies in the control box (see **Figure 6**) and install the new motor cords.
6. Open the motor junction box, remove the old motor cords, and rewire the motor terminals for 440V power, as illustrated in **Figure 8**.

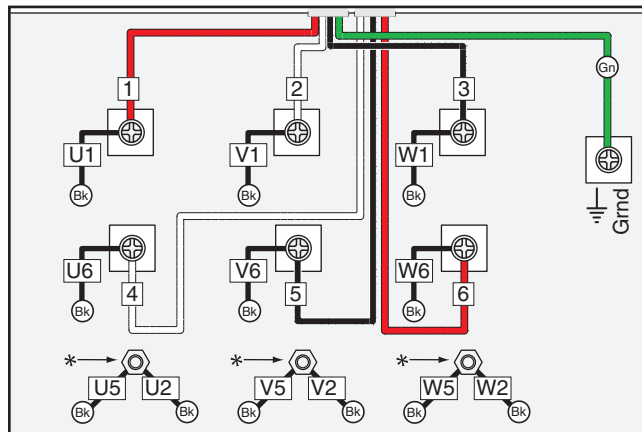

Figure 8. Model G0638 motor rewired for 440V.

7. Install the new motor cords on the motor (see **Figure 8**), and close the motor junction box.

!WARNING

You must have a qualified electrician inspect your 440V rewiring job before connecting the dust collector to the power source. Failure to heed this warning may result in property damage, serious personal injury, or death from electrocution.



Correcting Phase Polarity

This subsection is only provided for troubleshooting. If you discover during the test run that the machine will not operate, or that the impeller spins backward, the power connections may be wired out-of-phase. Without the proper test equipment to determine the polarity of the power source legs, wiring machinery to 3-phase power may require trial-and-error. Correcting phase polarity is simply a matter of reversing the positions where two of the incoming power source wires are connected inside the control box.

3. Secure the control box cover, then re-connect the machine to power.
4. Perform **Step 10** of the test run on **Page 34** to confirm that the power connections are correct.

—If the motor and impeller are still rotating in the wrong direction, contact our Tech Support at (570) 546-9663 for assistance.

NOTICE

If this machine is wired out-of-phase, the motor and impeller will spin in the wrong direction. The efficiency of the dust collector will be greatly reduced and will not provide the rated CFM. You must make sure the motor is spinning in the correct direction before placing the machine into full operation. Perform **Step 10** of the test run on **Page 34** to make sure the machine is correctly wired.

To correct phase polarity:

1. DISCONNECT MACHINE FROM POWER!
2. Open the control box and swap the connections of any two incoming hot wires from the power source (see **Figure 9**).

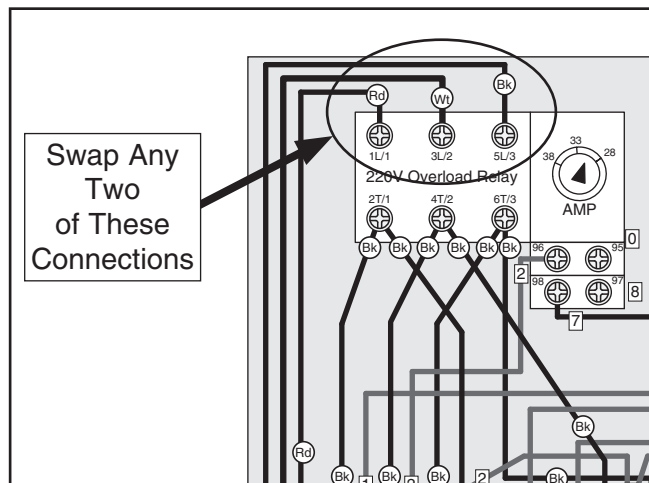
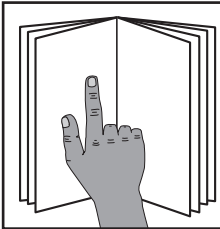

Figure 9. Connections to change when correction phase polarity.



SECTION 3: SETUP



!WARNING

To reduce your risk of serious injury, read this entire manual **BEFORE** using machine.

!WARNING

To reduce risk of eye injury from flying chips or lung damage from breathing dust, always wear safety glasses and a respirator when operating this machine.

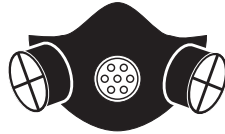

NOTICE

If you are not experienced with this type of machine, **WE STRONGLY RECOMMEND** that you seek additional training outside of this manual. Read books/magazines or get formal training before beginning any projects. Regardless of the content in this section, Grizzly Industrial will not be held liable for accidents caused by lack of training.

Needed for Setup

The following are needed to complete the setup process, but are not included with your machine:

Description	Qty
• Assistance	As Needed
• Power Lifting Equipment	As Needed
• Safety Glasses	For Each Person
• Wrenches 1/2"	2
• Wrenches 3/8"	2
• Wrench 5/16"	1
• Wrench 10mm	1
• Phillips Screwdriver #2	1
• Level (3 ft. or more in length)	1
• Floor Mounting Hardware	See Page 21
• Medium-Strength Thread Locking Compound	1 Bottle

Unpacking

Your machine was carefully packaged for safe transportation. Remove the packaging materials from around your machine and inspect it. If you discover any damage, *please call us immediately at (570) 546-9663 for advice.*

Save the containers and all packing materials for possible inspection by the carrier or its agent. *Otherwise, filing a freight claim can be difficult.*

When you are completely satisfied with the condition of your shipment, inventory the contents.

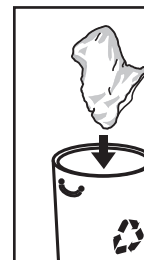

!WARNING

SUFFOCATION HAZARD!
Keep children and pets away from plastic bags or packing materials shipped with this machine. Discard immediately.



Inventory

The following is a list of items shipped with your machine. Before beginning setup, lay these items out and inventory them.

If any non-proprietary parts are missing (e.g. a nut or a washer), we will gladly replace them; or for the sake of expediency, replacements can be obtained at your local hardware store.

NOTICE

If you cannot find an item on this list, carefully check around/inside the machine and packaging materials. Often, these items get lost in packaging materials while unpacking or they are pre-installed at the factory.

After all the parts have been removed from the boxes, you should have the following items:

Inventory: (Figures 10–14)	Qty
A. Upper Stand Braces	4
B. Upper Stand Legs	4
C. Filter Brace Supports (Long)	2
D. Control Box Bracket	1
E. Cyclone Mounting Brackets.....	4
F. Lower Stand Legs	4
G. Filter L-Braces	2
H. Filter Brace Support (Short)	1
I. Lower Stand Braces	4

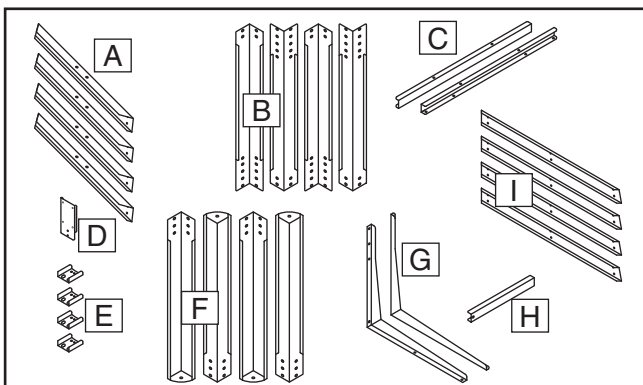

Figure 10. Model G0637/G0638 inventory A–I.

J. Intake Cylinder	1
K. Outlet Port	1
L. Cyclone Funnel (Large).....	1
M. Intake Barrel	1
N. Cyclone Funnel (Small)	1
O. Funnel Port.....	1

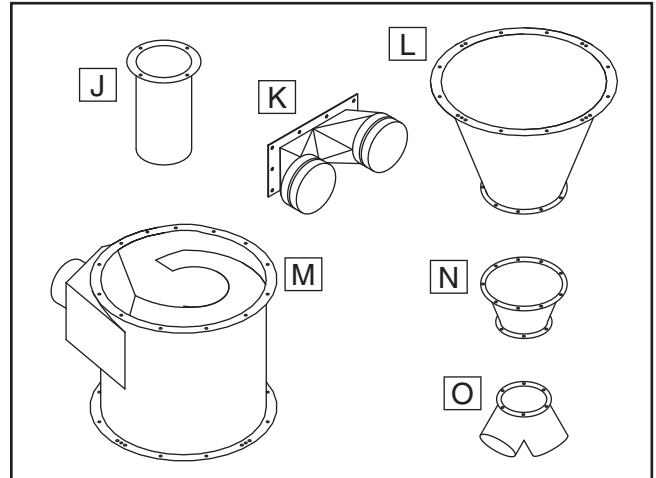

Figure 11. Model G0637/G0638 inventory J–O.

P. Blower Housing with Motor	1
Q. Control Box.....	1
R. Remote Control	1
S. Collection Drum Lid Latches	6
T. Casters 2"	8
U. Collection Drum Lids	2
V. Upper Collection Drum Cylinders.....	2
W. Collection Drum Clamps	2
X. Lower Collection Drum Cylinders.....	2

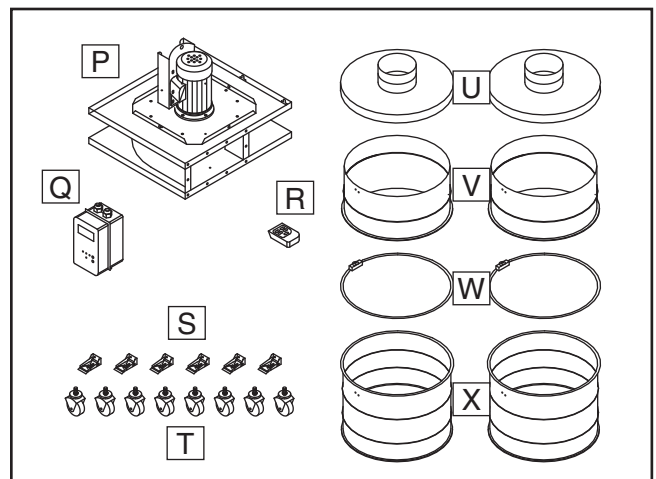

Figure 12. Model G0637/G0638 inventory P–X.



Y. Flexible Ducts 9" x 25½"	2
Z. Noise Mufflers	2
AA. Canister Filters	
—Model G0637 510 x 1200mm	2
—Model G0638 510 x 1500mm	2
AB. Flexible Ducts 8" x 31½"	2
AC. Flexible Ducts 8" x 4¾"	2
AD. Canister Filter Bag Clamps	2

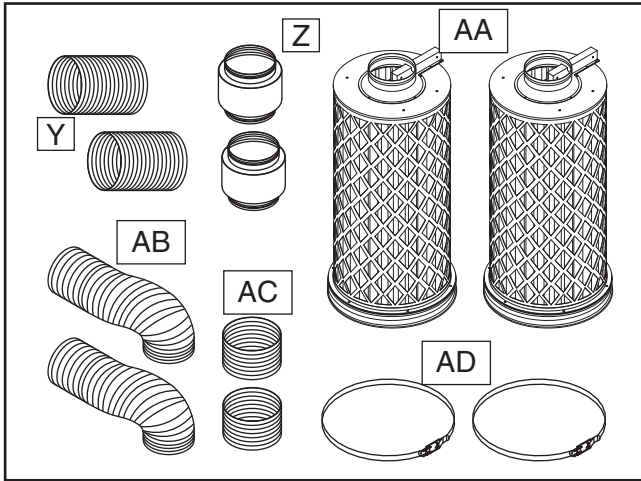

Figure 13. Model G0637/G0638 inventory Y-AD.

AE. Gaskets (not shown):	
—Intake Cylinder 3 x 6 x 1800mm	1
—Outlet Port 3 x 6 x 1100mm	1
—Cyclone Funnel (Large) 3 x 6 x 2500mm	1
—Intake Barrel 3 x 6 x 2500mm	1
—Cyclone Funnel (Small) 3 x 6 x 2200mm	1
—Funnel Port 3 x 6 x 735mm	1
—Canister Hose Gaskets 3 x 15 x 700mm	8
—Drum Lid PVC Rubber Seal	2
—Foam Tape 3 x 6 x 300mm	1
AF. Rubber Mounting Gaskets (not shown):	
—Filter Canisters	4
AG. Duct Clamps 8" (not shown)	8
AH. Duct Clamps 9" (not shown)	4
AI. Collection Bags (not shown):	
—Collection Drums 640 x 1200mm	12
—Canister Filters 570 x 600mm	2

AJ. Hardware (not shown):	
—Hex Bolts ¾"-16 x 1¼"	8
—Hex Bolts ⅝"-18 x ¾"	30
—Hex Bolts ⅝"-18 x 1"	10
—Hex Bolts ⅝"-18 x 1¼"	27
—Phillips Head Screws #10-24 x ⅜"	24
—Fender Washers ⅝"	8
—Flat Washers ⅝"	96
—Lock Washers ⅜"	8
—Hex Nuts ⅝"-18	37
—Hex Nuts #10-24	24
—Lock Nuts ⅜"-16	72
—G0637 (Only)	
—Hex Bolts ⅜"-16 x ¾"	75
—Flat Washers ⅜"	180
—Hex Nuts ⅜"-16	17
—G0638 (Only)	
—Hex Bolts ⅜"-16 x ¾"	74
—Flat Washers ⅜"	178
—Hex Nuts ⅜"-16	16
—G0638 (For Control Box Bracket)	
Phillips Head Screws M6-1 x 15	4
Flat Washers 6mm	4
Hex Nuts M6-1	4

AK. Vacuum Hose Clamps 1¼"	4
AL. Vacuum Hose 1¼" x 79"	2
AM. Vacuum Manifold	1
AN. Vacuum Hose Clamps 2"	2
AO. Vacuum Hose 2" x 39"	1
AP. Collection Drum Vacuum Ring	2
AQ. Cyclone Vacuum Port	1
AR. Vacuum Hose Clips	2

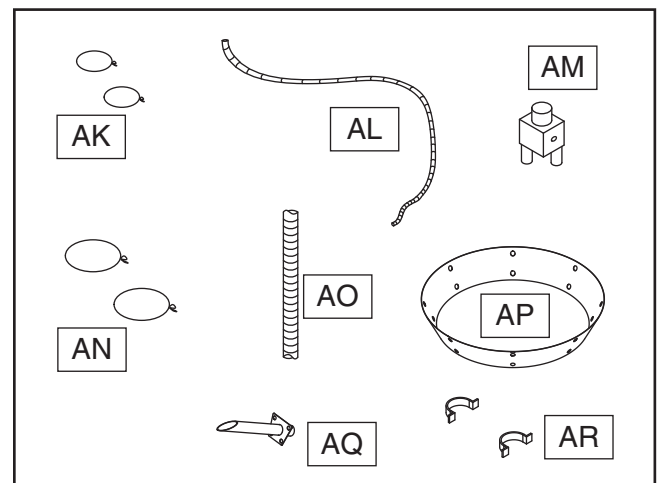

Figure 14. Model G0637/G0638 inventory AK-AR.



Site Considerations

Weight Load

Refer to the **Machine Data Sheet** for the weight of your machine. Make sure that the surface upon which the machine is placed will bear the weight of the machine, additional equipment that may be installed on the machine, and the heaviest workpiece that will be used. Additionally, consider the weight of the operator and any dynamic loading that may occur when operating the machine.

Space Allocation

Consider the largest size of workpiece that will be processed through this machine and provide enough space around the machine for adequate operator material handling or the installation of auxiliary equipment. With permanent installations, leave enough space around the machine to open or remove doors/covers as required by the maintenance and service described in this manual. **See below for required space allocation.**

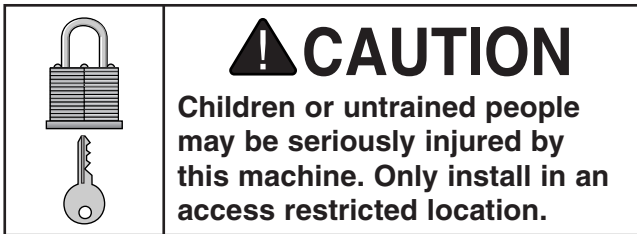

Physical Environment

The physical environment where the machine is operated is important for safe operation and longevity of machine components. For best results, operate this machine in a dry environment that is free from excessive moisture, hazardous chemicals, airborne abrasives, or extreme conditions. Extreme conditions for this type of machinery are generally those where the ambient temperature range exceeds 41°–104°F; the relative humidity range exceeds 20–95% (non-condensing); or the environment is subject to vibration, shocks, or bumps.

Electrical Installation

Place this machine near an existing power source. Make sure all power cords are protected from traffic, material handling, moisture, chemicals, or other hazards. Make sure to leave access to a means of disconnecting the power source or engaging a lockout/tagout device, if required.

Lighting

Lighting around the machine must be adequate enough that operations can be performed safely. Shadows, glare, or strobe effects that may distract or impede the operator must be eliminated.

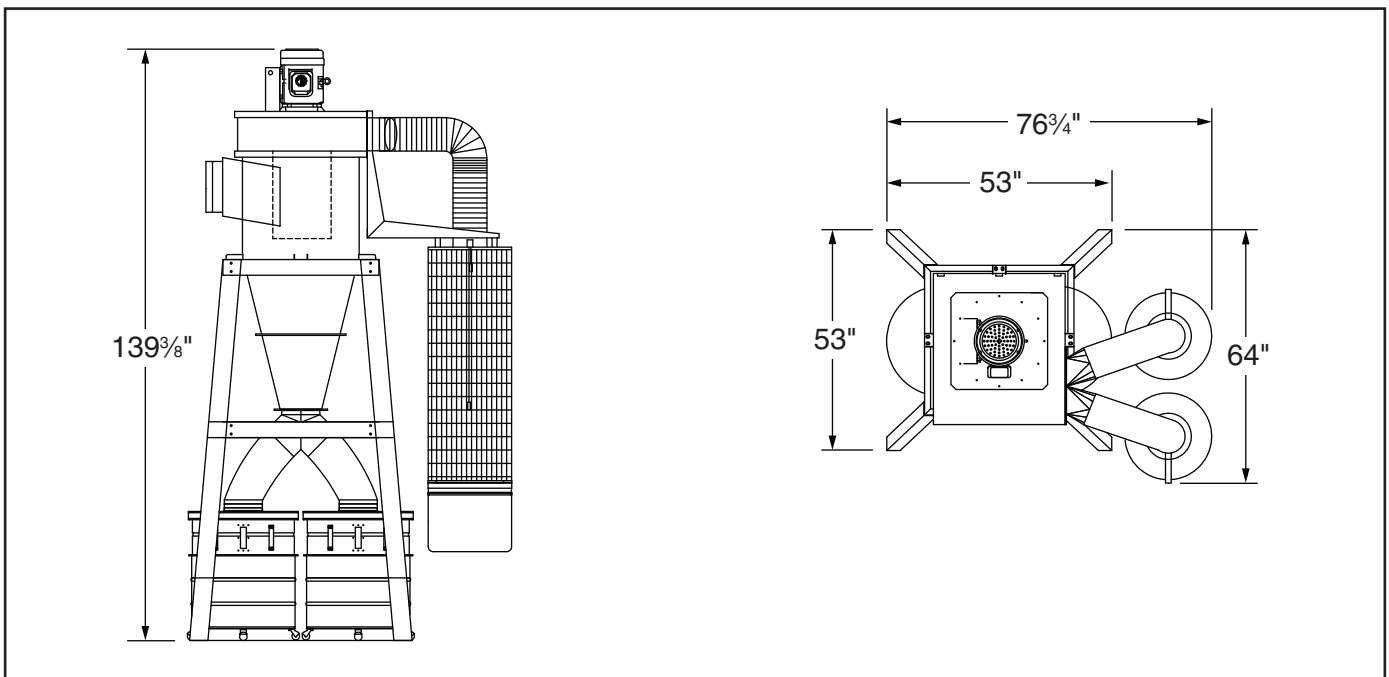

Figure 15. Minimum working clearances.



Mounting to Shop Floor

Since your dust collector will be hardwired to the power source, we strongly recommend securing your machine to the floor. Consult with your electrician to ensure compliance with applicable codes. Because floor materials may vary, floor mounting hardware is not included.

Bolting to Concrete Floors

Lag shield anchors with lag bolts and anchor studs (Figure 16) are two popular methods for anchoring an object to a concrete floor. We suggest you research the many options for mounting your machine and choose the one that best fits your specific application.

NOTICE

Anchor studs (see Figure 16) are stronger and more permanent alternatives to lag shield anchors; however, they will stick out of the floor, presenting a tripping hazard if you decide to move your machine.

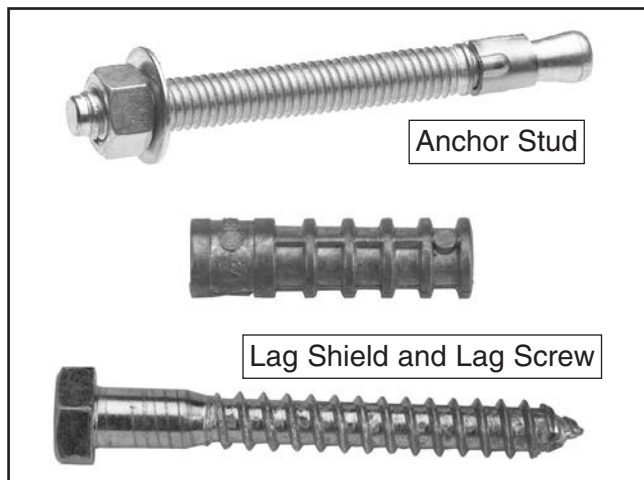

Figure 16. Typical fasteners for mounting to concrete floors.

Assembly

To assemble the dust collector:

1. Use (8) $\frac{3}{8}$ "-16 x $\frac{3}{4}$ " hex bolts, (16) $\frac{3}{8}$ " flat washers, and (8) $\frac{3}{8}$ "-16 lock nuts to connect 2 upper stand legs, 1 upper stand brace, and 1 lower stand brace —*only finger tighten the fasteners* (see Figure 17).

Note: To make the installation of the fasteners easier, use scrap wood to raise the metal components off the floor.

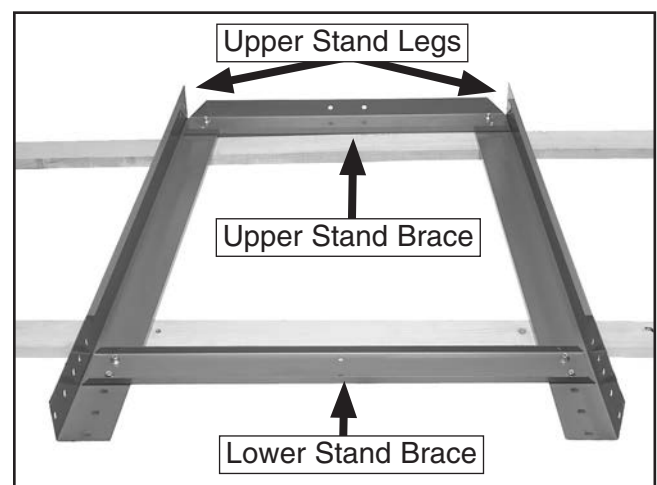

Figure 17. One side of upper stand assembled.

2. Repeat **Step 1** to make the other side of the upper stand.

Note: The $\frac{5}{16}$ " fender washers with a larger outside diameter will be used to attach the canister filters in later steps—do not use them for any other assembly.



3. Use (16) $\frac{3}{8}$ "-16 x $\frac{3}{4}$ " hex bolts, (32) $\frac{3}{8}$ " flat washer, and (16) $\frac{3}{8}$ "-16 lock nuts to connect the two sides of the upper stand with two upper stand braces and two lower stand braces—*only finger tighten the fasteners* (see **Figure 18**).



Figure 18. Upper stand assembled.

4. Place the level across a corner of the lower stand braces and move the upper stand around until that corner is level, then fully tighten all of the fasteners for that corner (see **Figure 19**).

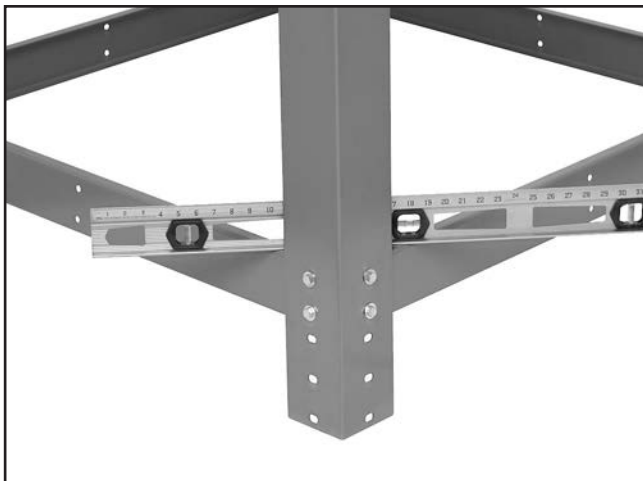

Figure 19. Level positioned on the upper stand.

5. Repeat **Step 4** for the rest of the corners, then set the upper stand assembly aside.

!WARNING

When using power lifting equipment during the assembly, make sure the equipment is safe, fully operational, and adequately rated for the weight being lifted. The operator of the equipment must be experienced and able to use safe methods during these processes. Failure to heed these warnings could result in serious personal injury or death.

6. Place the intake cylinder on the floor and apply the 3 x 6 x 1800mm gasket to the intake cylinder top rim, between the mounting holes and the inside edge (see **Figure 20**).

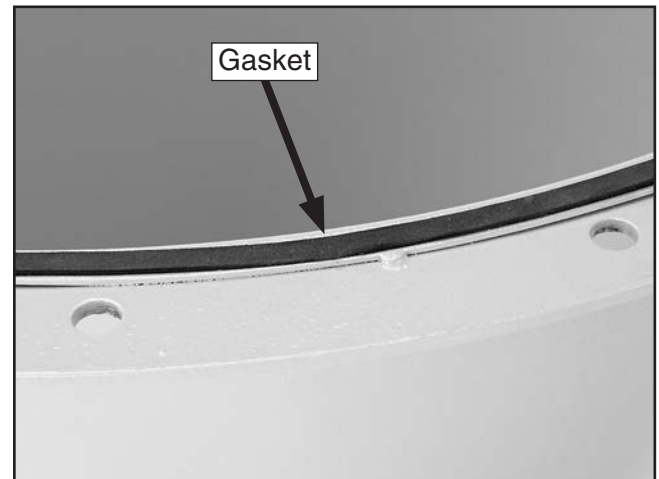

Figure 20. Gasket applied to the intake cylinder rim.

7. With assistance and the power lifting equipment, keep the intake cylinder on the floor and lower the blower housing over the top of the intake cylinder.



- Use the (6) $\frac{5}{16}$ "-18 x $\frac{3}{4}$ " hex bolts and (6) $\frac{5}{16}$ " flat washers to secure the intake cylinder to the bottom of the blower housing (see **Figure 21**).

Note: Because this part of the dust collector is not accessible after assembly, consider using Medium Strength Blue Thread Locker (Grizzly Model T21854) on the bolts that secure the intake cylinder to the motor/blower housing assembly to ensure that the fasteners won't come loose with vibration.



Figure 21. Intake cylinder mounted to blower housing.

- Position the large cyclone funnel so the small end rests on the floor.
- Apply the 3 x 6 x 2500mm gasket to the top mating surface of the large cyclone funnel.

Note: When aligning the holes in the next step, be aware that the large cyclone funnel top and the intake barrel mating surfaces have four places around the rims where there are three mounting holes close together.

- With assistance, place the intake barrel over the large cyclone funnel and align the mounting holes as illustrated in **Figure 22**.

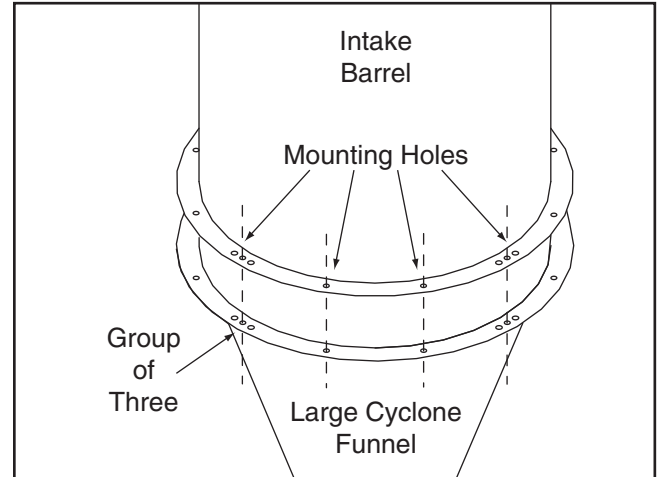

Figure 22. Intake barrel and large cyclone funnel mounting holes aligned.

NOTICE

When connecting parts that have a gasket applied to the mounting surface, always tighten the fasteners in an opposing star pattern to ensure the gasket does not become crimped and compromise the seal.

- Connect the intake barrel and large cyclone funnel with (12) $\frac{5}{16}$ "-18 x $1\frac{1}{4}$ " hex bolts, (24) $\frac{5}{16}$ " flat washers, and (12) $\frac{5}{16}$ "-18 hex nuts in the mounting holes—excluding the left and right hole of the groups of three (see **Figure 23**).

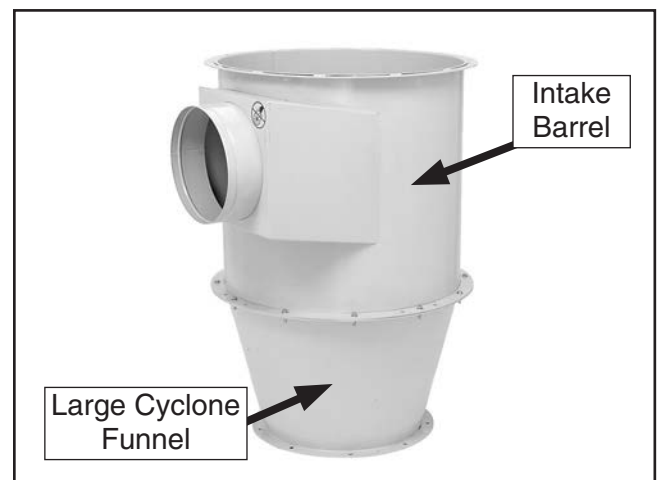

Figure 23. Intake barrel and large cyclone funnel.



13. Install the four cyclone mounting brackets with (8) $\frac{3}{8}$ "-16 x $1\frac{1}{4}$ " hex bolts, (16) $\frac{3}{8}$ " flat washers, and (8) $\frac{3}{8}$ "-16 lock nuts (see **Figures 22 & 24**).



Figure 24. Cyclone mounting bracket mounted to collector assembly.

14. Apply the 3 x 6 x 2500mm gasket to the top mating surface of the intake barrel assembly.
15. Keeping the intake barrel assembly on the floor, lower the blower housing assembly over and approximately one inch away from the intake barrel assembly.
16. Using two punches or Phillips screwdrivers as alignment guides (see **Figure 25**), lower the blower housing assembly onto the intake barrel assembly.

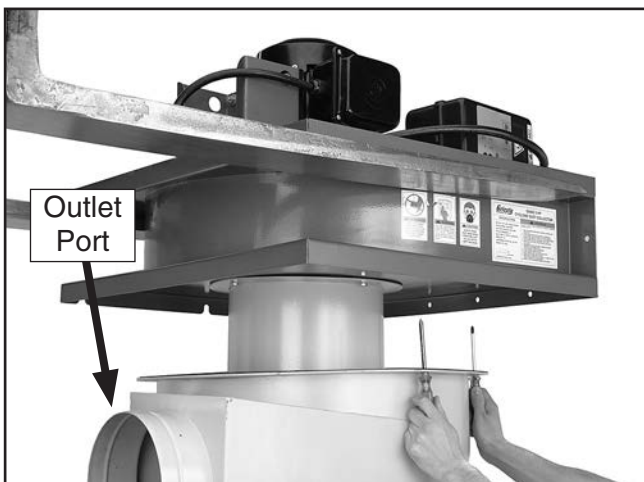

Figure 25. Aligning the mounting holes.

Note: Orient the two assemblies so that the large, round intake port of the intake barrel is NOT directly underneath the rectangular outlet port of the blower housing. The outlet port will connect to the canister filters and will not allow room for attachment of the intake ducting to the intake port.

17. Attach the two assemblies with the (12) $\frac{5}{16}$ "-18 x $\frac{3}{4}$ " hex bolts and (12) $\frac{5}{16}$ " flat washers (see **Figure 26**).



Figure 26. Securing intake barrel assembly to blower housing assembly.

Tip: When installing the two bolts above the intake port of the intake barrel, use duct tape on the bottom of your wrench. This will hold the bolts in the wrench while inserting them in place (see **Figure 27**).

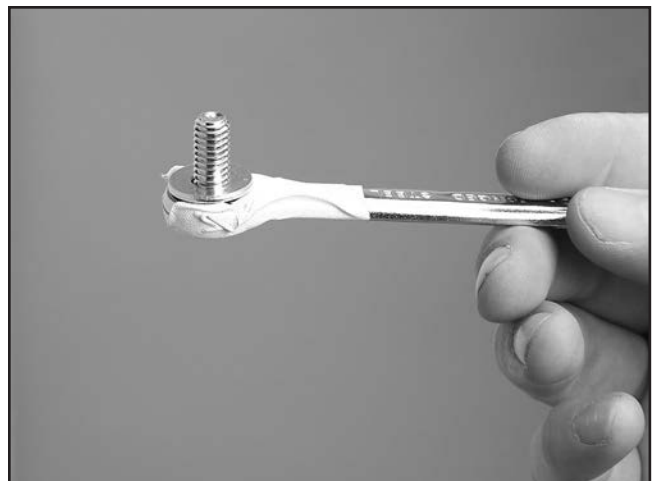

Figure 27. Using tape on a wrench in a tight spot.



18. Apply the 3 x 6 x 300mm foam tape to the mating surface of the cyclone vacuum port, then attach it to the cyclone funnel with (4) $\frac{5}{16}$ "-18 x $\frac{3}{4}$ " hex bolts and (4) $\frac{5}{16}$ " flat washers (see **Figure 28**).

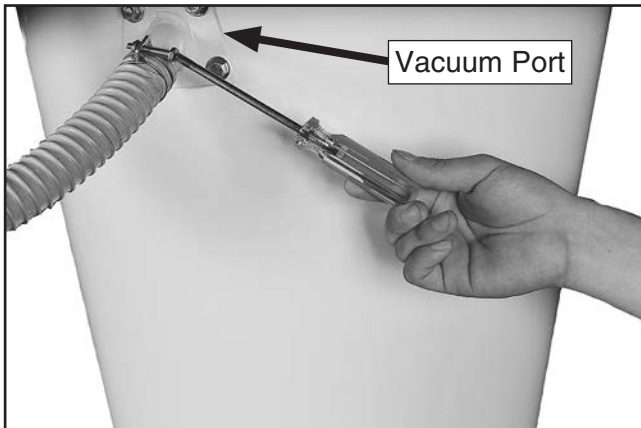

Figure 28. Cyclone vacuum tube and hose attachment.

19. Lower the blower/intake assembly into the upper stand assembly so that the cyclone mounting brackets align with the mounting holes of the upper stand braces (see **Figure 29**).

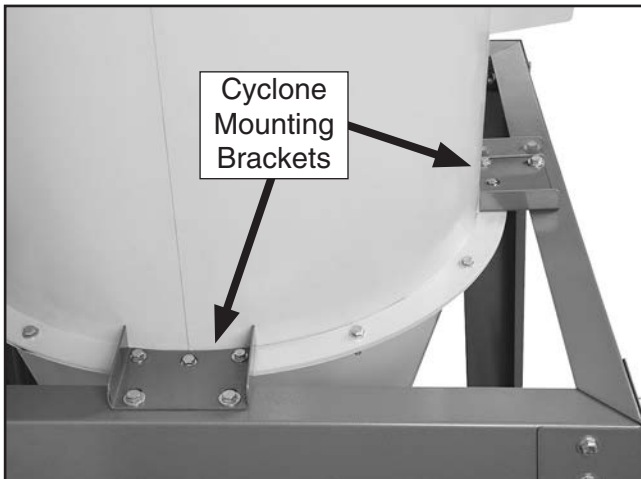

Figure 29. Mounting blower/intake assembly to upper stand.

20. Secure the mounting brackets to the upper stand with (8) $\frac{3}{8}$ "-16 x $\frac{3}{4}$ " hex bolts, (16) $\frac{3}{8}$ " flat washers, and (8) $\frac{3}{8}$ "-16 lock nuts.
21. With assistance and the power lifting equipment, raise the entire assembly high enough to install the lower stand legs.

22. Slide the four lower stand legs onto the bottoms of the upper stand legs—do NOT install the fasteners yet.

23. Slowly lower the weight of the assembly onto the lower stand legs.

Note: To keep the assembly stable while completing the next steps, keep the power lifting equipment engaged but not lifting.

24. To allow the mounting holes of the lower stand legs to align properly, slightly loosen the 16 fasteners that connect the lower stand braces to the upper stand legs (see **Figure 30**).

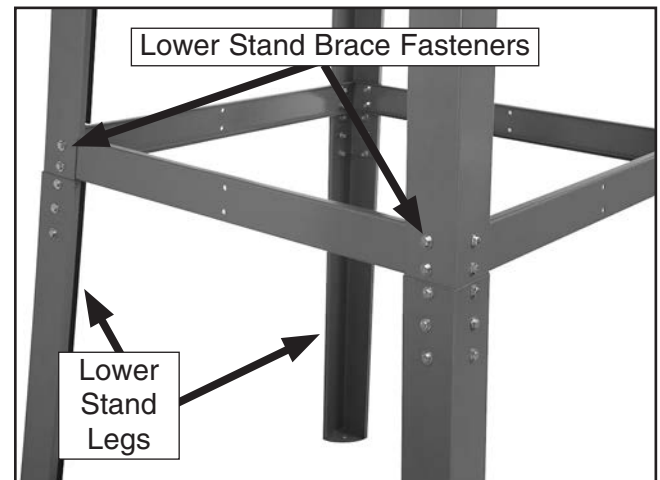

Figure 30. Lower stand legs attached to the upper stand assembly.

25. Secure the lower stand legs to the upper stand assembly with (24) $\frac{3}{8}$ "-16 x $\frac{3}{4}$ " hex bolts, (48) $\frac{3}{8}$ " flat washers, and (24) $\frac{3}{8}$ "-16 lock nuts.

26. Re-tighten the 16 fasteners connecting the lower stand braces to the assembly.

27. Remove the power lifting equipment from the assembly.

Note: The only other use for the power lifting equipment is moving the dust collection system into its permanent position when the assembly is complete.



28. Apply the 3 x 6 x 1100mm gasket to the square side of the outlet port.
29. Attach (1) 3 x 15 x 700mm gasket to the outer circular rims of each outlet port.
30. Mount the outlet port to the blower housing with (4) $\frac{5}{16}$ "-18 x 1" hex bolts, (8) $\frac{5}{16}$ " flat washers, and (4) $\frac{5}{16}$ "-18 hex nuts (see **Figure 31**).

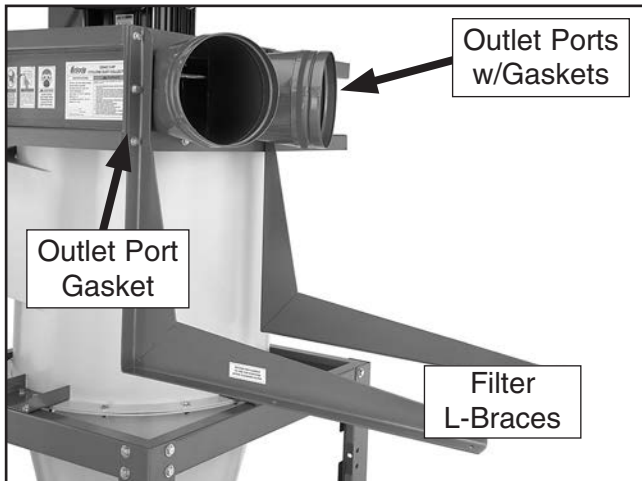

Figure 31. Filter L-braces mounted to blower housing.

31. Attach the filter L-braces to either side of the outlet port on the blower housing with (6) $\frac{5}{16}$ "-18 x 1" hex bolts, (12) $\frac{5}{16}$ " flat washers, and (6) $\frac{5}{16}$ "-18 hex nuts.
32. Secure the short filter brace support to the back of the filter L-braces with (2) $\frac{3}{8}$ "-16 x $\frac{3}{4}$ " hex bolts, (4) $\frac{3}{8}$ " flat washers, and (2) $\frac{3}{8}$ "-16 hex nuts (see **Figure 32**).

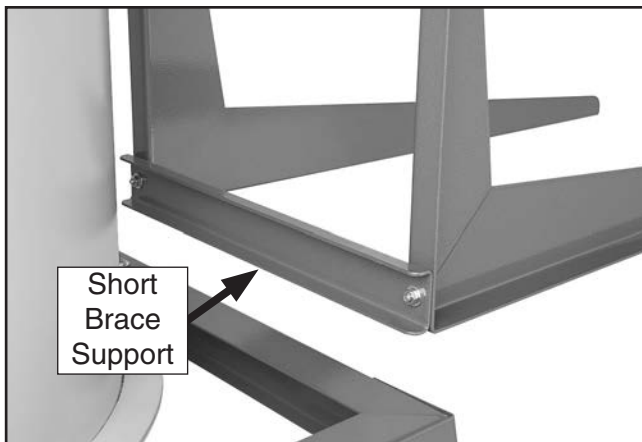

Figure 32. Short filter brace support attached.

33. Attach the two long brace supports to the filter braces with (4) $\frac{3}{8}$ "-16 x $\frac{3}{4}$ " hex bolts, (8) $\frac{3}{8}$ " flat washers, and (4) $\frac{3}{8}$ "-16 hex nuts, as shown in **Figure 33**.



Figure 33. Long brace supports attached.

34. With assistance, position the rubber mounting gaskets between the filter canisters and the long brace supports, and secure the canisters with (8) $\frac{5}{16}$ "-18 x $\frac{3}{4}$ " hex bolts and (8) $\frac{5}{16}$ " fender washers (see **Figure 34**).

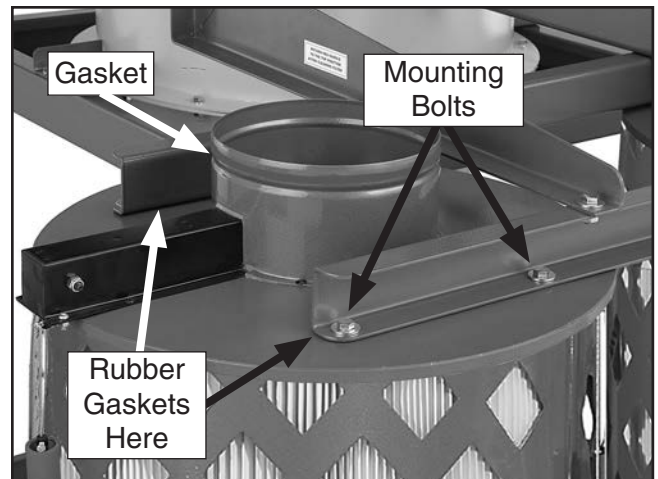

Figure 34. Canister filters mounted to the long support braces.



35. Attach the 3 x 15 x 700mm gaskets to the upper rim of the canister filter assembly and both rims of the noise muffler.
36. Assemble the 8" x 31½" flexible ducts, the noise mufflers, and the 8" x 4¾" flexible ducts with the 8" duct clamps (see **Figure 35**).

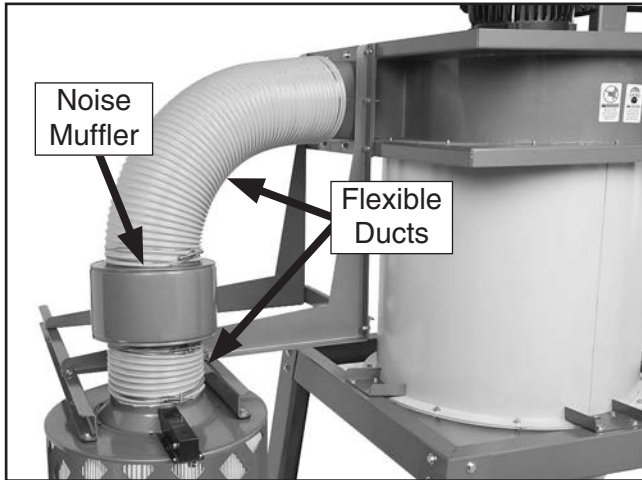

Figure 35. Ducting and noise muffler connected between blower housing and filter canister.

37. Use the 8" duct clamps to connect the duct assemblies between the outlet port of the blower housing and the canister filters.
38. Fit the smaller plastic collection bags over the bottom of the filters and clamp them in place with the metal bag clamps, as shown in **Figure 36**.



Figure 36. Canister filter collection bag installed.

39. Apply the 3 x 6 x 2200mm gasket to the larger, top end of the small cyclone funnel, then place the cyclone funnel upside down on the floor.

Note: Use a clean covering on the floor to protect the gasket.

40. Apply the 3 x 6 x 735mm gasket to the top of the funnel port and place this upside down on top of the cyclone funnel.
41. Attach the small cyclone funnel and funnel port with (6) ⅝"-18 x 1¼" hex bolts, (12) ⅝" flat washers, and (6) ⅝"-18 hex nuts.
42. With assistance, attach this assembly to the bottom of the large cyclone funnel with (9) ⅝"-18 x 1¼" hex bolts, (18) ⅝" flat washers, and (9) ⅝"-18 hex nuts (see **Figure 37**).

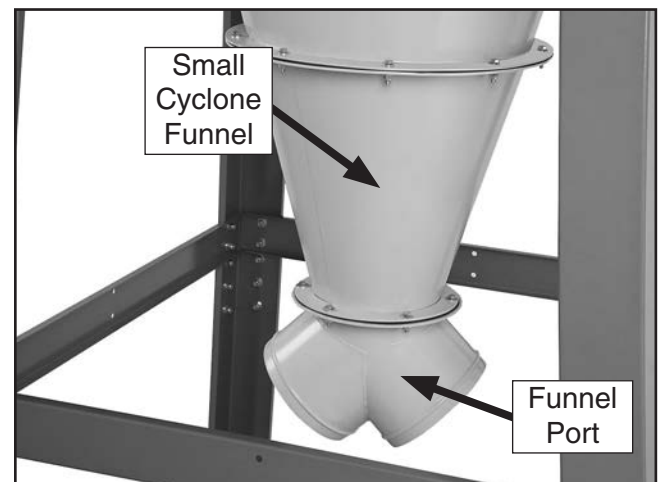

Figure 37. Small cyclone funnel and funnel port attached.



43. For each lower collection drum cylinders, attach the casters to the bottom using (4) $\frac{3}{8}$ "-16 hex nuts, (4) $\frac{3}{8}$ " flat washers, and (4) $\frac{3}{8}$ " lock washers (see **Figure 38**).



Figure 38. Dust collection drum casters installed.

44. Connect each upper and lower collection drum cylinder with a collection drum clamp and use (1) $\frac{5}{16}$ "-18 x 3" hex bolt and (1) $\frac{5}{16}$ "-18 hex nut to tighten the clamp (see **Figure 39**).

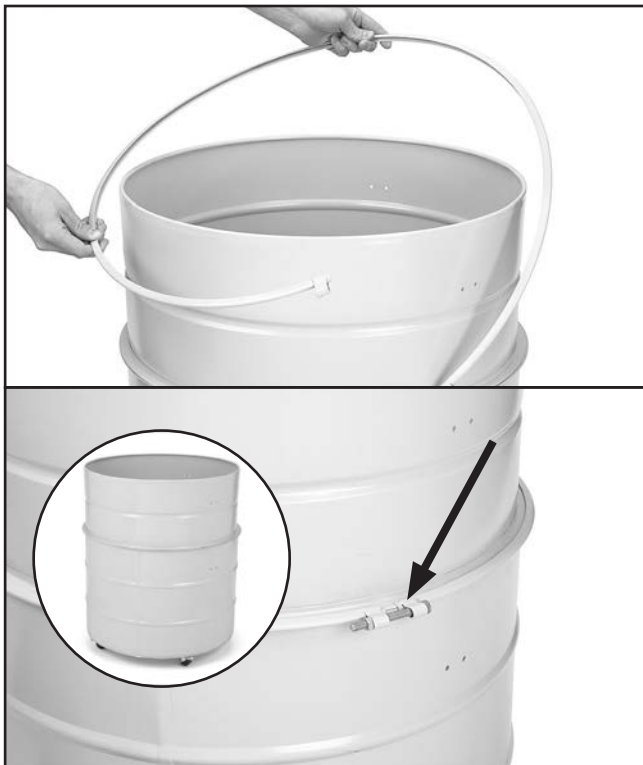

Figure 39. Installing drum clamp around dust collection cylinders.

45. Install the rubber seal over the top lip of the collection drum rim. Pay special attention to the direction of the seal, as shown in the **Figure 40**.

Tip: To keep the seal in place, you can use an adhesive applied to the rubber seal at approximately 1" intervals.

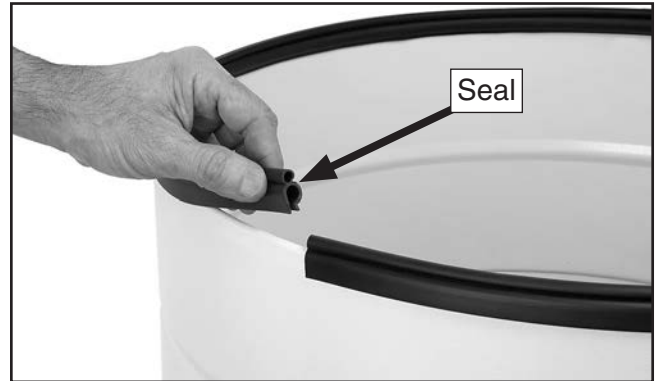

Figure 40. Installing drum seal.

46. Install the drum lid latches on the upper part of each collection drum assembly with (12) #10-24 x $\frac{3}{8}$ " Phillips head screws and (12) #10-24 hex nuts (see **Figure 41**).



Figure 41. Collection drum lid latch installed.

47. To prevent a vacuum leak in the collection drums, use (12) #10-24 x $\frac{3}{8}$ " Phillips head screws and (12) #10-24 hex nuts to plug the holes in the lower half of the collection drums.



48. Place the collection drum vacuum rings on the bottom of the collection drums (see **Figure 42**).

Note: During operation, this ring and the vacuum connection to the cyclone funnel will prevent the collection bag from collapsing.

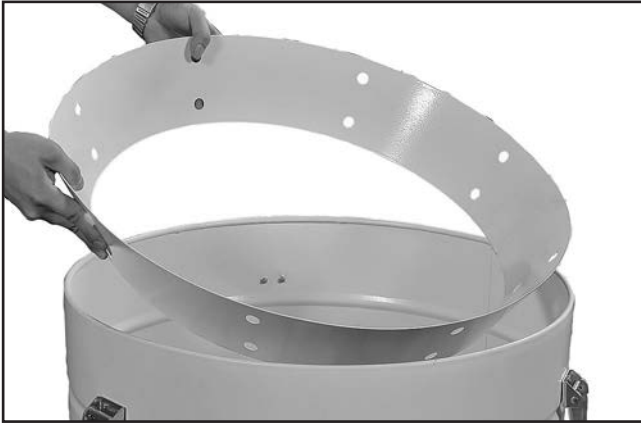

Figure 42. Inserting collection drum vacuum ring.

49. Install the larger plastic collection bag into the drum, place the lid on it and hook the latch over the lid, as shown in **Figure 43**, then clamp it in place.



Figure 43. Latch hooked over the lid for clamping.

50. Connect the dust collection drum assemblies to the funnel port with the 9" flexible ducts and 9" duct clamps (see **Figure 44**).

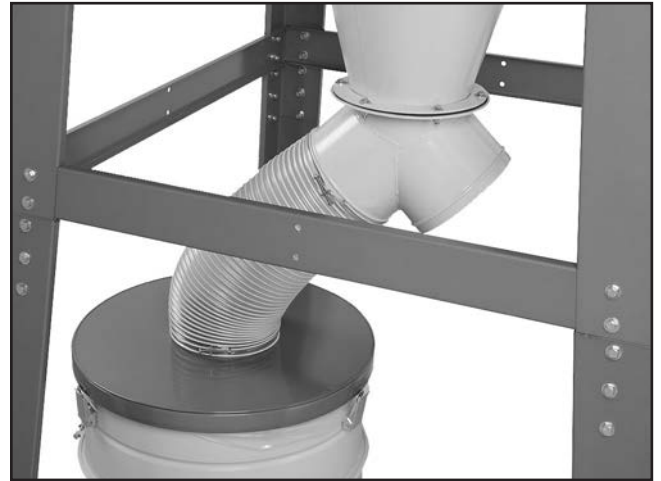

Figure 44. Dust collection drum assemblies connected to funnel port.

51. Use the 2" hose clamps to attach one end of the 2" x 39" vacuum hose to the cyclone vacuum port and the other end to the vacuum manifold (see **Figure 45**).

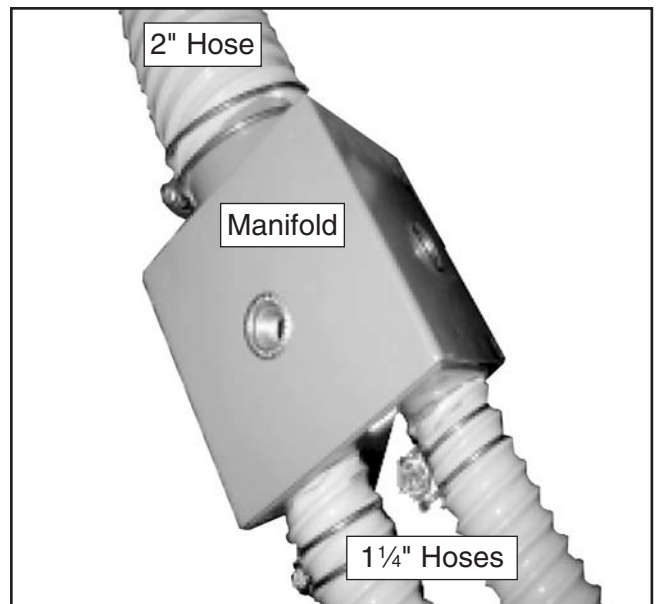

Figure 45. Vacuum hoses attached to the vacuum manifold.



52. Connect the vacuum hoses between the vacuum manifold and the collection drum vacuum ports with (4) 1¼" hose clamps (see **Figure 45–46**).



Figure 46. Connecting the vacuum hose.

53. Secure the vacuum hose inside the upper and lower stand legs with the (2) U-shaped clips (see **Figure 47**).



Figure 47. Securing the vacuum hose to the stand legs.

54. **Model G0637 only:** Mount the control box onto the lower stand brace with (3) ⅜"-16 x ¾" hex bolts, (6) ⅜" flat washers, and (3) ⅜"-16 hex nuts (see **Figure 48**).

Note: The remote control uses IR (infrared) to communicate with the control box, and must have direct line-of-sight to the control box. Locate the control box with this in mind.



Figure 48. Model G0637 control box mounted.

55. **Model G0638 only:** Mount the control bracket onto the lower stand brace with (2) ⅜"-16 x ¾" hex bolts, (4) ⅜" flat washers, and (2) ⅜"-16 hex nuts (see **Figure 49**).



Figure 49. Model G0638 control box bracket mounted.



56. Open the control box and identify the four mounting holes in the back of the cabinet.
57. Attach the control box to the bracket already mounted on the stand brace with (4) M6-1 x 15 Phillips head screws, (4) 6mm flat washers, and (4) M6-1 hex nuts (see **Figure 50**).



Figure 50. Model G0638 control box mounted.

NOTICE

If the control box is locked, use the included key to unlock it for access to complete set up. Always lock the box and keep the key in a safe and secure location to prevent unauthorized access.

Power Connection

Due to the complexity required for planning, bending, and installing the conduit necessary for a code-compliant hardwire setup, an electrician or other qualified person **MUST** perform this type of installation. Hardwire setups typically require power supply wires to be enclosed inside of a solid or flexible conduit, which is securely mounted at both ends with the appropriate conduit fittings. All work must adhere to the required electrical codes.

The hardwire setup for this machine must include a locking disconnect switch (see **Figure 51**) between the power source and the machine. This switch serves as the means to completely disconnect the machine from power to prevent electrocution accidental startup during adjustments, maintenance, or service to the machine.

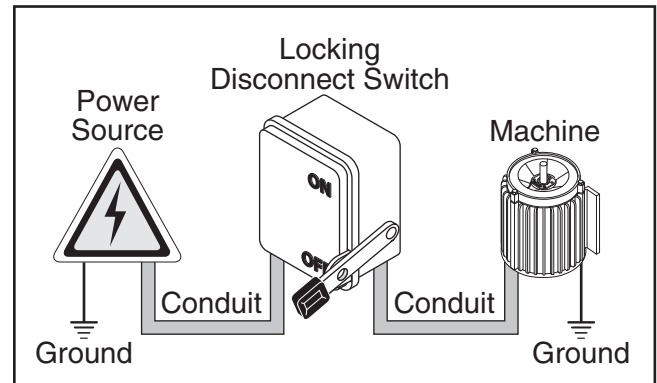

Figure 51. Typical hardwire setup with a locking disconnect switch.



G0637 Power Connection

The incoming power wires must be connected to the three terminals on the master power switch marked 1L/1, 3L/2, and 5L/3, and the incoming ground wire must be connected the ground terminal shown in **Figure 52**. All wires must have adequate slack and be clear of sharp objects.

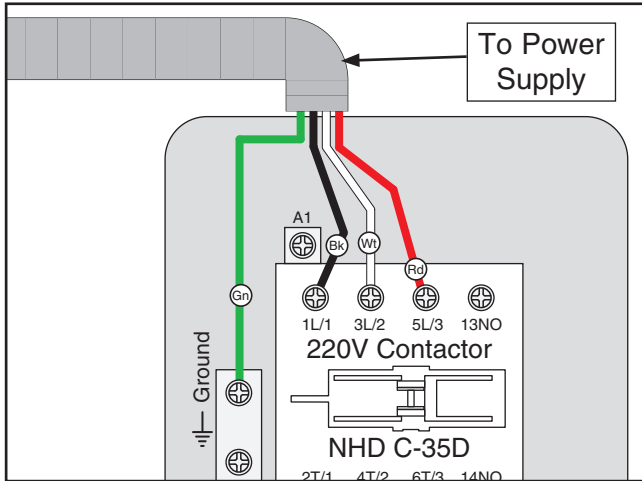

Figure 52. G0637 mag switch to power supply connection.

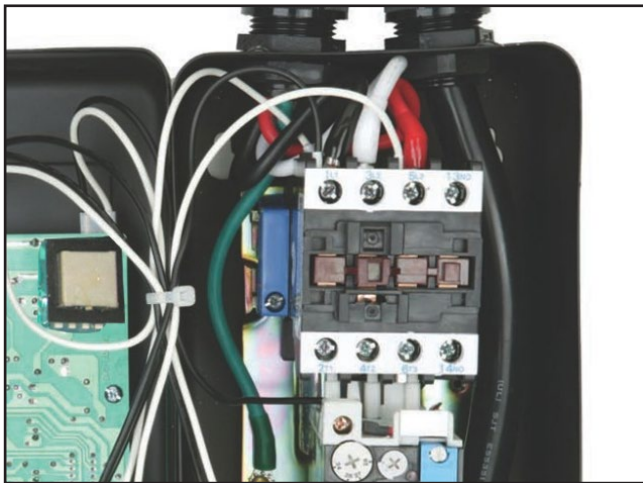

Figure 53. G0637 mag switch wiring.

G0638 Power Connection

The incoming power wires must be connected to the three terminals on the overload relay marked 1L/1, 3L/2, and 5L/3, and the incoming ground wire must be connected the ground terminal shown in **Figure 54**. All wires must have adequate slack and be clear of sharp objects.

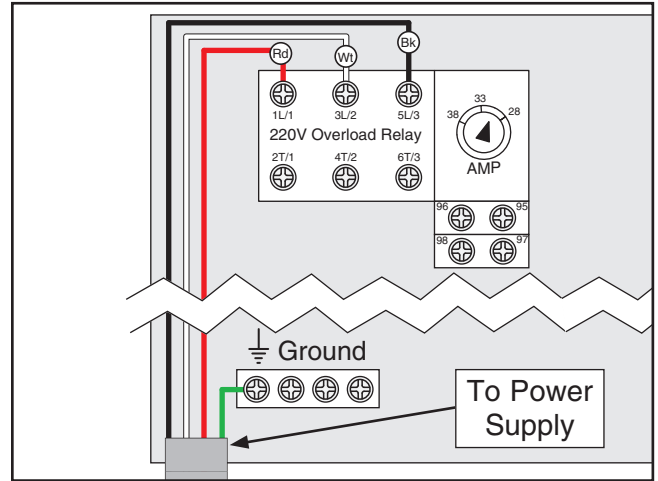

Figure 54. G0638 overload relay to power supply connection.

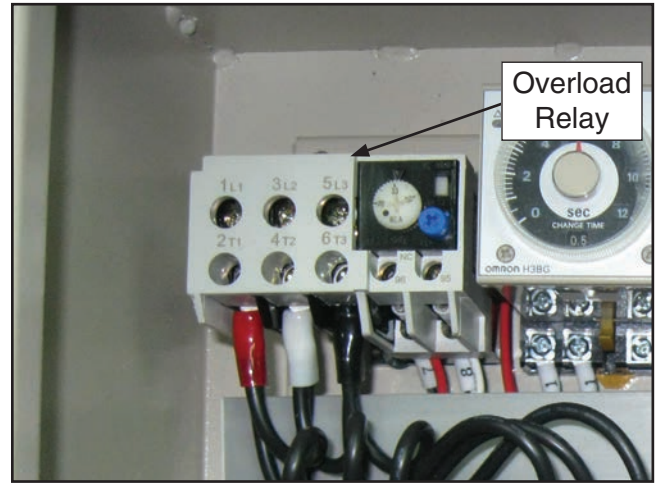

Figure 55. G0638 overload relay.



Test Run

When the assembly is complete, test run your dust collection system to make sure it operates properly.

If, during the test run, you cannot easily locate the source of an unusual noise or vibration, stop using the machine immediately, then review the **Troubleshooting** on **Page 50**.

If you still cannot remedy a problem, contact our Tech Support at (570) 546-9663 for assistance.

To test run your dust collection system:

1. Make sure you have read the safety instructions at the beginning of the manual and that the machine is setup properly.
2. Make sure all tools and objects used during setup are cleared away from the machine.
3. Review **Power Supply** on **Page 12** and connect the machine to the power source.
4. Flip the main power switch at the lower left hand corner of the control box (see **Figures 56**) to (I) from (O).

Note: For the Model G0638, make sure the **EMERGENCY STOP** button is popped out by twisting the knurled knob clockwise.

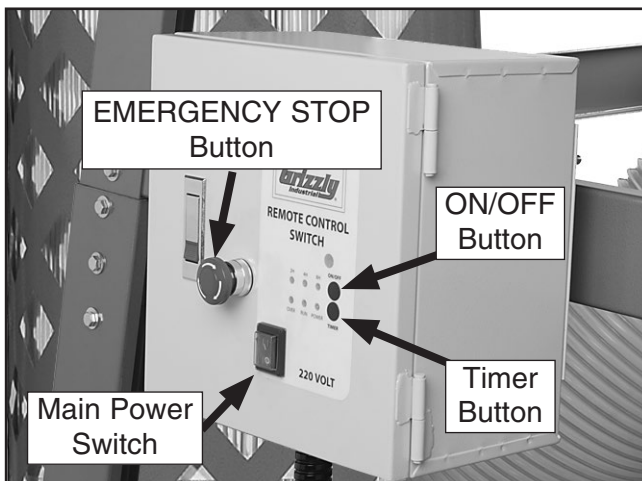

Figure 56. Control box (Model G0638 shown).

5. Press the ON/OFF button to turn the machine **ON**. Make sure your hand stays poised over the switch in case you need to quickly turn the machine **OFF**.

6. Listen to and watch for abnormal noises or actions. The machine should run smoothly with little or no vibration or rubbing noises.

—If you suspect any problems, immediately turn the machine **OFF** and disconnect the machine from power. Refer to **Troubleshooting** on **Page 50** to identify and fix any problems.

—If you cannot solve the problem with the use of the **Troubleshooting** guide, contact our Tech Support at (570) 546-9663 for assistance.

7. Press the TIMER button on the control box and cycle through each of the times to make sure the indicators light.

8. Press the TIMER button on the remote control and cycle through the times in the same manner as **Step 7**.

9. Toggle the ON/OFF button on both the control box and the remote control to make sure they are working properly.

Note: For proper operation, the impeller inside the blower housing must be rotating counterclockwise. Since the motor and impeller are directly connected, you will verify in the next step that the motor is rotating in the correct direction.

Keep in mind that if the motor is rotating in the incorrect direction, the dust collector will still operate but with drastically reduced performance.

!WARNING

If any part of your body contacts the spinning impeller, severe cutting or amputation injuries could occur. Always keep well away from the impeller and never use any tools near the impeller when the machine is connected to power.



10. Safely use a ladder so that you can observe the motor fan through the top motor cover. Stay clear of the motor, then use the remote control to turn the motor **ON** and **OFF** while you note the fan rotation direction.

—If the motor fan is rotating *counterclockwise* while looking down on it, the rotation direction is correct.

—If the motor fan is rotating *clockwise*, the rotation direction is incorrect and the motor is receiving power out-of-phase. You will need to perform the **Correcting Phase Polarity** procedure on **Page 16** so that the impeller will rotate in the correct direction.

11. For the G0638 only:

- a. Turn the machine **OFF**.
- b. Press the EMERGENCY STOP button in.
- c. Turn the machine **ON**—nothing should happen.
- d. Turn the machine **OFF**.
- e. Pop the EMERGENCY STOP button out by twisting the knurled knob clockwise.
- f. Pressing the ON/OFF button should now turn the dust collector **ON**.



SECTION 4: DESIGNING THE SYSTEM

General



The Model G0637/G0638 is designed to be a central dust collector system. Install the dust collector in an out of the way location such as a corner or separate room. The large suction capacity of the Model G0637/G0638 allows great flexibility in planning and designing of your dust collection duct layout. Grizzly offers a complete line of dust collection accessories for setting up a stationary system. Additionally, Grizzly offers a complete guide book titled *Dust Collection Basics*.

Whatever system design you choose, always make sure there are no open flames (including pilot lights) in the same room as the dust collector; otherwise you risk an explosion if dust is dispersed into the air.

Duct Material

You have many choices regarding main line and branch line duct material. For best results, use metal duct for the main line and branch lines, then use short lengths of flexible hose to connect each machine to the branch lines.

Plastic duct is also a popular material for home shops. However, be aware that there is a fire or explosion hazard if plastic duct material is used for dust collection without being grounded against static electrical charge build-up. This topic will be discussed later in this section. Another problem with using plastic is that it is less efficient per foot than metal.

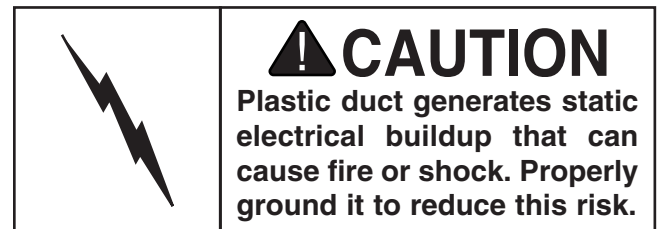

Plastic Duct

The popularity of plastic duct is due to the fact that it is an economical and readily available product. It is also simple to assemble and easily sealed against air loss. The primary disadvantage of plastic duct for dust collection is the inherent danger of static electrical build-up.



Figure 57. Examples of plastic ducting components.



Metal Duct

Advantages of metal duct is its conductivity and that it does not contribute to static electrical charge build-up. However, static charges are still produced when dust particles strike other dust particles as they move through the duct. Since metal duct is a conductor, it can be grounded quite easily to dissipate any static electrical charges.

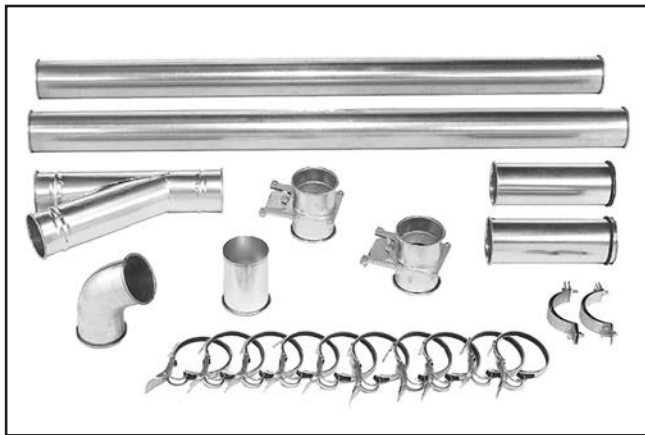

Figure 58. Examples of metal pipe and components.

There are a number of options when it comes to metal duct, but metal duct that is specially manufactured for dust collection is the best choice. When selecting your metal duct, choose high quality metal duct with smooth welded internal seams that will minimize airflow resistance. This type of duct usually connects to other ducts or elbows with a simple, self-sealing clamp, is very quick and easy to assemble, and can be readily dismantled and re-installed. This is especially important if you ever need to change things around in your shop or add more tools.

Avoid inferior metal duct that requires you to cut it to length and snap it together. This type of duct is time consuming to install because it requires you to seal all the seams with silicone and screw the components on the ends with sheet metal screws. Another disadvantage is the rough internal seams and crimped ends that unavoidably increase static pressure loss.

Flexible Duct

Flexible hose is generally used for short runs, small shops and at rigid duct-to-tool connections. There are many different types of flex hose on the market today. These are manufactured from materials such as polyethylene, PVC, cloth hose dipped in rubber and even metal, including steel and aluminum.

The superior choice here is metal flex hose that is designed to be flexible, yet be as smooth as possible to reduce static pressure loss.

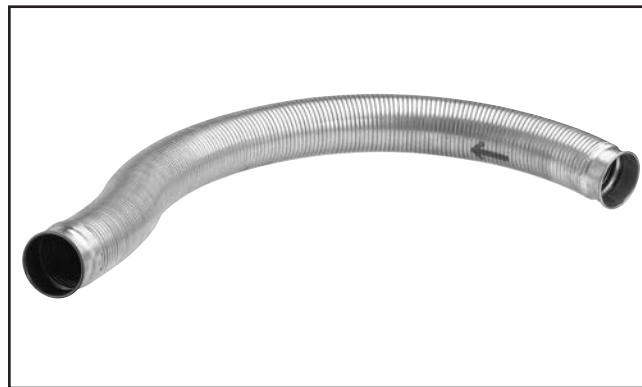

Figure 59. Example of flexible metal duct.

There are also many kinds of pure plastic flexible hose, such as non-perforated drainage type hose and dryer vent hose. Drainage type hose, while being economical, does not quite have the flexibility required for dust collection. The inside of the duct is also deeply corrugated and can increase the static pressure loss by as much as 50% over smooth wall duct. Dryer vent hose, while being completely flexible, is non-resistant to abrasion and has a tendency to collapse in a negative pressure system. We DO NOT recommend using dryer vent hose in your dust collection system.

If using flex-hose, you should choose one of the many types that are designed specifically for the movement of solid particles, i.e. dust, grains, and plastics. However, the cost of specifically designed flexible duct can vary greatly. Grizzly offers polyethylene hose, which is well suited for the removal of particulate matter, especially sawdust, since it is durable and completely flexible. Polyethylene is also very economical and available in a wide variety of diameters and lengths for most applications.



System Design

Decide Who Will Design

For most small-to-medium sized shops, you can design and build the dust collection system yourself without hiring engineers or consultants. We have included some basic information here to get you started on a basic design.

If you have a large shop or plan to design a complicated system, we recommend doing additional research beyond this manual or seeking the help of an expert.

Sketch Your Shop Layout

When designing a successful dust collection system, planning is the most important step. In this step, sketch a basic layout of your shop, including space requirements of different machines.

Before you get out your pencil and paper, we recommend you visit our FREE *Workshop Planner*, at <http://www.grizzly.com/workshopplanner>.

Our *Workshop Planner* will allow you to quickly and easily design and print a basic shop layout. Don't worry, non-Grizzly brand machines can be substituted with Grizzly machines for layout purposes. **Note:** After you're finished, make sure to save your layout for later modification.

Your sketch only needs the basic details of the shop layout, similar to the figure below, including all your current/planned machines and your planned placement of the dust collector.

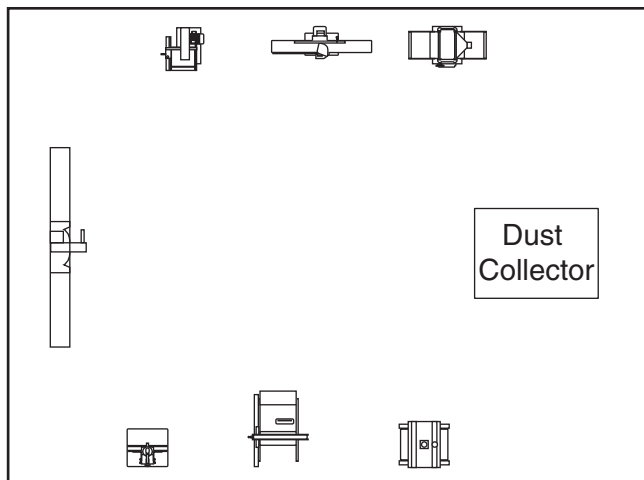

Figure 60. Basic sketch of shop layout.

Sketch a Basic Duct Layout

For the next step, sketch how you will connect your machines to the dust collector. Consider these general guidelines for an efficient system:

1. Machines that produce the most saw dust should be placed nearest to the dust collector (i.e. planers and sanders).
2. Ideally, you should design the duct system to have the shortest possible main line and secondary branch ducts. See the figures below for ideas of efficient versus inefficient duct layouts.

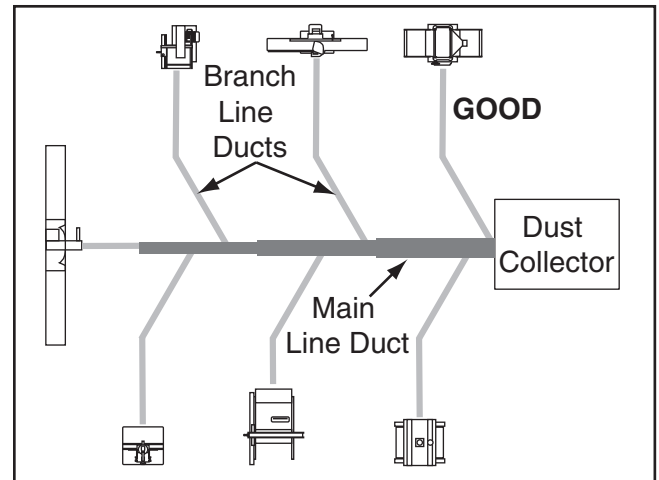

Figure 61. Efficient duct layout.

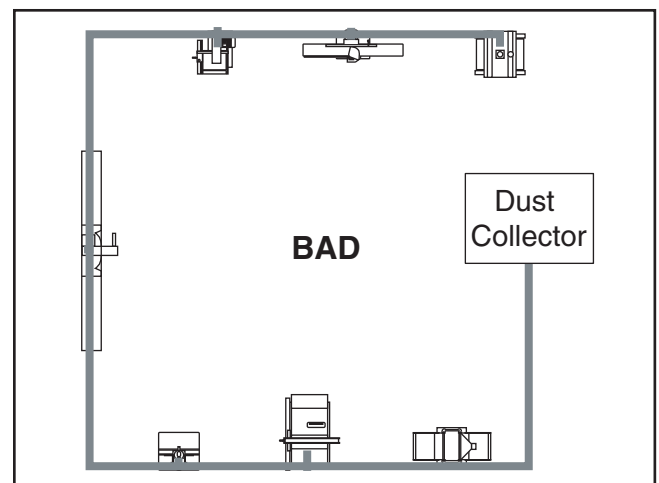

Figure 62. Inefficient duct layout.



3. Directional changes should be kept to a minimum. The more directional change fittings you use directly increases the overall resistance to airflow.
4. Gradual directional changes are more efficient than sudden directional changes (i.e. use the largest corner radius possible when changing hose or pipe direction).
5. Each individual branch line should have a blast gate immediately after the branch to control suction from one machine to another.
6. The simpler the system, the more efficient and less costly it will be.

Determine Required CFMs

Since each machine produces a different amount of sawdust, the requirements for the minimum amount of CFM to move that sawdust is unique to the machine (for example, a planer produces more sawdust than a table saw). Knowing this required CFM is important to gauging which size of duct to use.

Refer to the figure below for a close estimation of the airflow each machine requires. Keep in mind that machines that generate the most sawdust should be placed closest to the dust collector. If the machine has multiple dust ports, the total CFM required is the sum of all ports.

Machine Dust Port Size	Approximate Required CFM
2"	98
2.5"	150
3"	220
4"	395
5"	614
6"	884
7"	1203
8"	1570
9"	1990
10"	2456

Figure 63. Approximate required airflow for machines, based on dust port size.

If the machine does not have a built-in dust port, use the following table to determine which size of dust port to install.

Machine	Average Dust Port Size
Table Saw.....	4"
Miter/Radial-Arm Saw.....	2"
Jointer (6" and smaller)	4"
Jointer (8"-12")	5"
Thickness Planer (13" and smaller).....	4"
Thickness Planer (14"-20")	6"
Shaper.....	4"
Router (mounted to table).....	2"
Bandsaw.....	4"
Lathe.....	4"
Disc Sander (12" and smaller).....	2"
Disc Sander (13-18").....	4"
Belt Sander (6" and smaller)	2"
Belt Sander (7"-9")	3"
Edge Sander (6" x 80" and smaller).....	4"
Edge Sander (6" x 80" and larger)	5"
Drum Sander (24" and smaller).....	2 x 4"
Drum Sander (24" and larger)	4 x 4"
Widebelt Sander (18" and smaller).....	5"
Widebelt Sander (24"-37" single head) ...	2 x 6"
Widebelt Sander (24"-51" double head) ..	5 x 4"

Figure 64. Dust port size and quantity per average machine.

Write the required CFM for each machine on your sketch, as shown in the figure below.

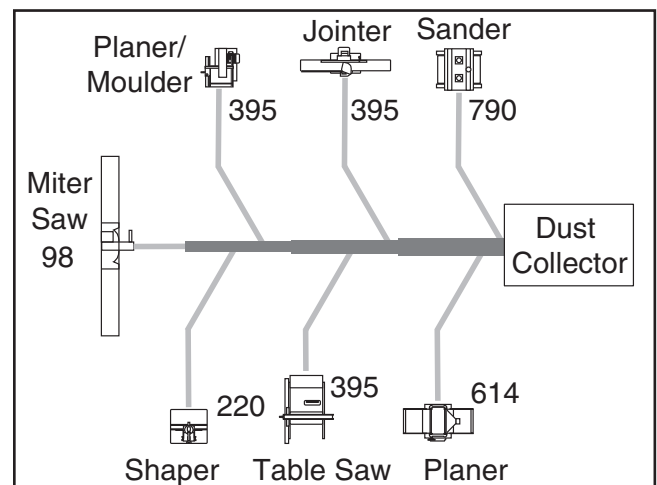

Figure 65. CFM requirements labeled for each machine.



Determining Main Line Duct Size

The general rule of thumb for a main line duct is that the velocity of the airflow must not fall below 3500 FPM.

For small/medium sized shops, using the inlet size of the dust collector as the main line duct size will usually keep the air velocity above 3500 FPM and, depending on your system, will allow you to keep multiple branches open at one time.

Mark your drawing, as shown in the figure below, but using the inlet size for your dust collector as the main line.

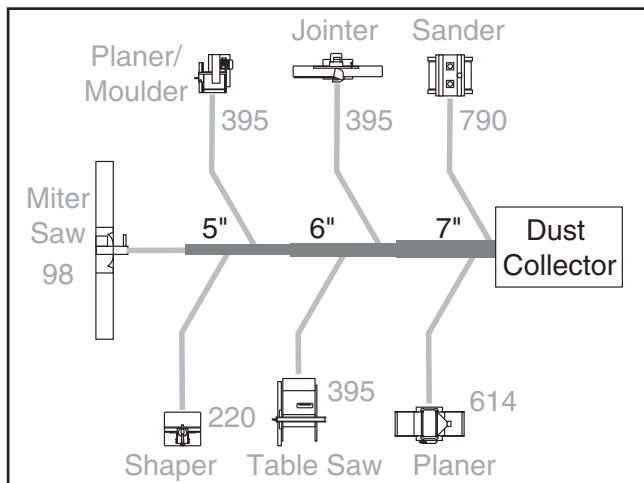

Figure 66. Main line size labeled on sketch.

Determining Branch Line Duct Size

The general rule of thumb for a branch line duct is that the velocity of the airflow must not fall below 4000 FPM.

For small/medium sized shops, using the dust port size from the machine as the branch line duct size will achieve the correct velocity in most applications. However, if the dust port on the machine is smaller than 4", make the branch line 4" and neck the line down right before the dust port.

Note: Systems with powerful dust collectors work better if multiple blast gates are left open. This also allows you to run two machines at once. Experiment with different combinations of blast gates open/closed to find the best results for your system.

Write your determined branch line sizes on your drawing, as shown in the following figure.

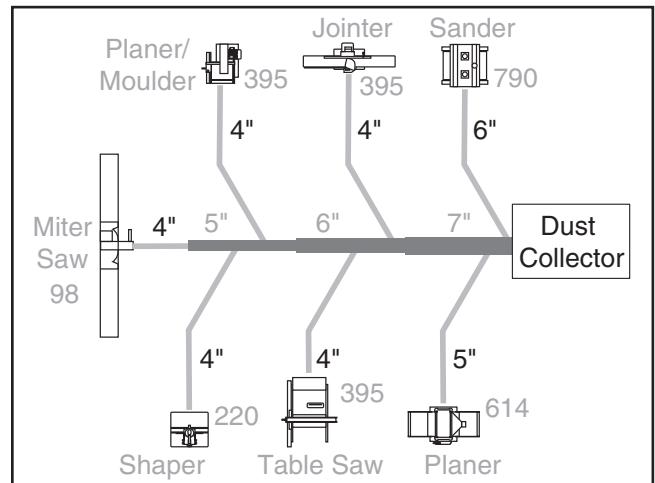

Figure 67. Branch line duct sizes labeled.

If two machines will connect to the same branch line and both will operate at the same time, then add the required CFM for each machine together and find the closest total CFM in the table below to determine the correct branch size.

If both machines will never run at the same time, reference the machine with the biggest dust port in the table below and add blast gates after the Y-branch to open/close the line to each machine.

Total CFM	Branch Line Size
400	4"
500	4"
600	5"
700	5"
800	6"
900	6"
1000	6"

Figure 68. Sizing chart for multiple machines on the same branch line.



Planning Drop Downs

Plan the drop downs for each machine, using blast gates wherever possible to control airflow.

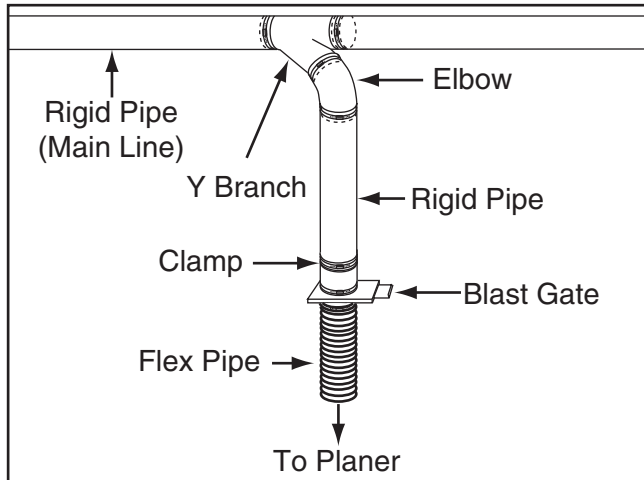

Figure 69. Drop down setup.

Calculating Duct Resistance

Adding duct work, elbows, branches and any other components to a duct line increases airflow resistance (static pressure loss). This resistance can be minimized by using rigid (smooth) pipe and gradual curves, as opposed to flexible pipe and 90° elbows.

To help you think about this resistance, imagine riding a bicycle in a tunnel that is an exact replica of your duct work. If the inside of the tunnel is very bumpy (flexible pipe) and has a lot of sharp turns (90° elbows), it will take a lot more effort to travel from one end to the other.

The purpose of calculating the resistance is to determine if it is low enough from the machine to the dust collector to meet the given CFM requirement for the machine. Use the following tables to calculate the resistance of duct work.

Duct Dia.	Approximate Static Pressure Loss Per Foot of Rigid Pipe		Approximate Static Pressure Loss Per Foot of Flex Pipe	
	Main Lines at 3500 FPM	Branch Lines at 4000 FPM	Main Lines at 3500 FPM	Branch Lines at 4000 FPM
2"	0.091	0.122	0.35	0.453
2.5"	0.08	0.107	0.306	0.397
3"	0.071	0.094	0.271	0.352
4"	0.057	0.075	0.215	0.28
5"	0.046	0.059	0.172	0.225
6"	0.037	0.047	0.136	0.18
7"	0.029	0.036	0.106	0.141
8"	0.023	0.027	0.08	0.108
9"	0.017	0.019	0.057	0.079

Fitting Dia.	90° Elbow	45° Elbow	45° Wye(Y)	90° Wye(Y)
3"	0.47	0.235	0.282	0.188
4"	0.45	0.225	0.375	0.225
5"	0.531	0.266	0.354	0.236
6"	0.564	0.282	0.329	0.235
7"	0.468	0.234	0.324	0.216
8"	0.405	0.203	0.297	0.189

Figure 70. Static pressure loss charts.

In most small/medium shops it is only necessary to calculate the line with the longest duct length or the most fittings (operating under the assumption that if the line with the highest resistance works, the others will be fine).

To calculate the static pressure of any given line in the system, follow these steps:

1. Make a list of each size duct in the line, including the length, and multiply those numbers by the static pressure value given in the previous table.
2. List each type of elbow or branch and multiply the quantity (if more than one) by the static pressure loss given in the previous table.



3. Add the additional factors from the following table to your list.

Additional Factors	Static Pressure
Seasoned (well used) Dust Collection Filter	1"
Entry Loss at Large Machine Hood	2"

Figure 71. Additional factors affecting static pressure.

4. Total your list as shown in the example below to come up with your overall static pressure loss number for that line.

Note: Always account for a seasoned filter, so you don't end up with a system that only works right when the filter is clean.

Main Line		
6" Rigid Pipe (0.037) at 20'	0.740
Branch Line		
4" Rigid Pipe (0.075) at 10'	0.750
4" Flex Pipe (0.28) at 5'	1.400
Elbows/Branches		
6" 45° Y-Branch	0.329
4" 45° Elbow	0.225
Additional Factors		
Seasoned Filter	<u>1.000</u>
Total Static Pressure Loss	4.444

Figure 72. Totaling static pressure numbers.

Note: When calculating static pressure loss to determine if multiple lines can be left open at the same time, only include the main line numbers once.

5. Compare the total static pressure loss for that line to the closest CFM given in **Figure 74 or 75** for your dust collector on **Page 42**.

Example: A typical **Data Sheet Performance Curve** is illustrated in **Figure 73**. Find 4.4 on the Static Pressure axis (the amount of total static pressure loss calculated in **Figure 72**), then refer to the closest value on the CFM axis—approximately 1120 CFM.

The 1120 CFM for the static pressure loss of the line connected to the router is well above the 220 CFM requirement of that machine.

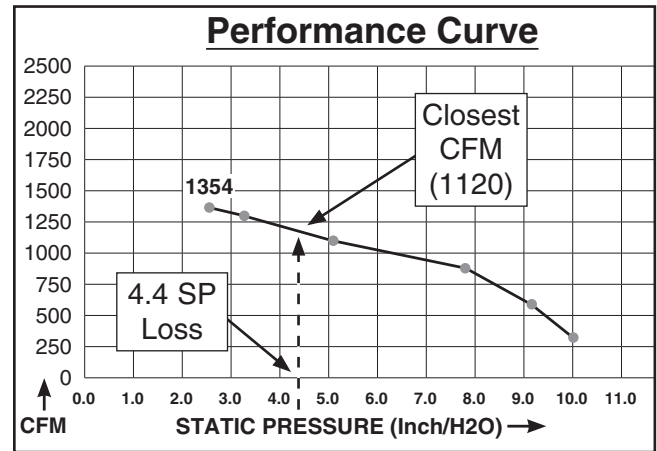

Figure 73. CFM for static pressure loss of line connected to a dust collector & router.

—If the CFM for your static pressure loss is above the requirement of the machine connected to the end of that branch line, then dust collection will most likely be successful. Congratulations! You've just designed your own dust system. Refer to the **Accessories** section on **Page 44** to start buying the components necessary to make your system a reality.

—If the CFM for your static pressure loss is below the requirement of the machine, then that line will not effectively collect the dust. You must then modify some of the factors in that line to reduce the static pressure loss. Some of the ways to do this include 1) installing larger duct, 2) reducing amount of flexible duct used, 3) increasing machine dust port size, 4) moving machine closer to dust collector to eliminate duct length, and 5) reducing 90° elbows or replacing them with 45° elbows.



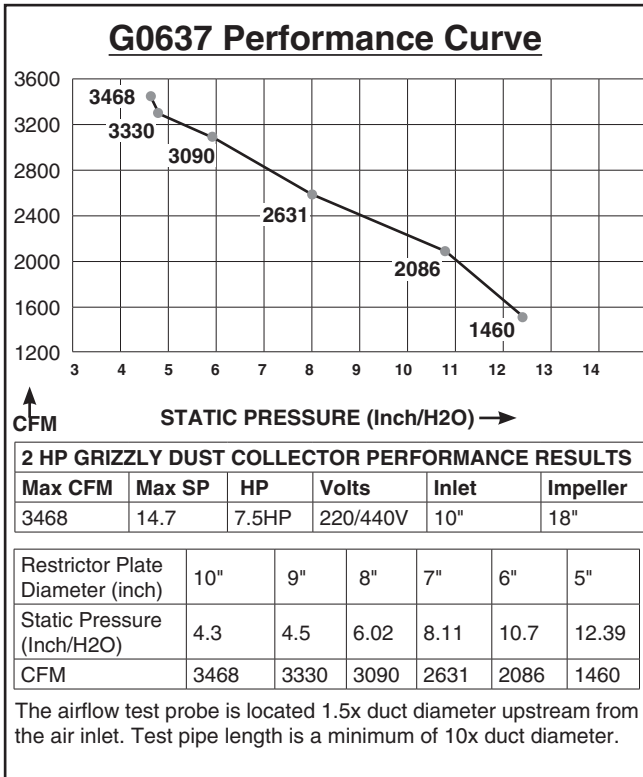

Figure 74. G0637 performance curve chart and data.

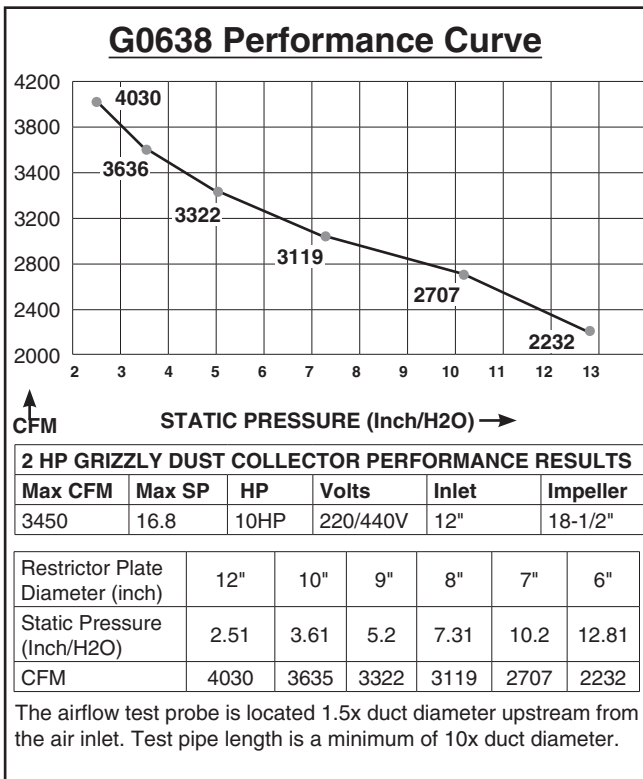

Figure 75. G0638 performance curve chart and data.

Example Materials List

After the system is designed, create a materials list of all the items you will need to build your dust collection system. This will make it easy when it comes time to purchase the materials.

Below is an example of some items that might be needed. Refer to **Accessories** for dust collection components available through grizzly.com.

Description	Model	Quantity
6" Rigid Pipe at 20'	G7364	4
4" Rigid Pipe at 10'	G6162	2
4" Flex Hose at 5'	H7215	6
6" 45° Y-Branch	G7353	6
4" 45° Elbow	G6167	6

Figure 76. Example of dust collection system material list.



System Grounding

Since plastic hose is abundant, relatively inexpensive, easily assembled and air tight, it is a very popular material for conveying dust from woodworking machines to the dust collector. We recommend using flexible hose (flex-hose) to connect the woodworking machine to the dust collector. However, plastic flex-hose and plastic duct are an insulator, and dust particles moving against the walls of the plastic duct create a static electrical build up. This charge will build until it discharges to a ground. If a grounding medium is not available to prevent static electrical build up, the electrical charge will arc to the nearest grounded source. This electrical discharge may cause an explosion and subsequent fire inside the system.

To protect against static electrical build up inside a non-conducting duct, a bare copper wire should be placed inside the duct along its length and grounded to the dust collector. You must also confirm that the dust collector is continuously grounded through the electrical circuit to the electric service panel.

If you connect the dust collector to more than one machine by way of a non-conducting branching duct system and blast gates, the system must still be grounded as mentioned above. We recommend inserting a continuous bare copper ground wire inside the entire duct system and attaching the wire to each grounded woodworking machine and dust collector.

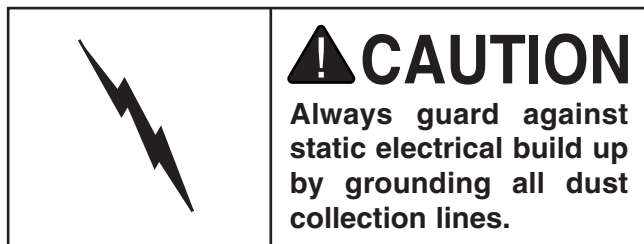

Be sure that you extend the bare copper wire down all branches of the system. Do not forget to connect the wires to each other with wire nuts when two branches meet at a “Y” or “T” connection.

Ensure that the entire system is grounded. If using plastic blast gates to direct air flow, the grounding wire must be jumped (see the figure below) around the blast gate without interruption to the grounding system.

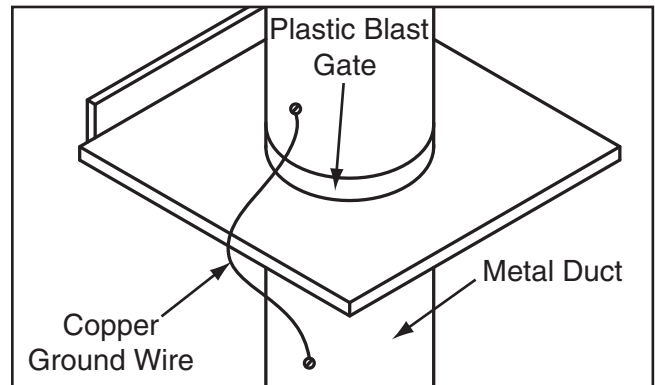

Figure 77. Ground jumper wire when using plastic blast gates and metal duct.

We also recommend wrapping the outside of all plastic ducts with bare copper wire to ground the outside of the system against static electrical build up. Wire connections at Y’s and T’s should be made with wire nuts.

Attach the bare ground wire to each stationary woodworking machine and attach to the dust collector frame with a ground screw as shown in the figure below. Ensure that each machine is continuously grounded to the grounding terminal in your electric service panel.

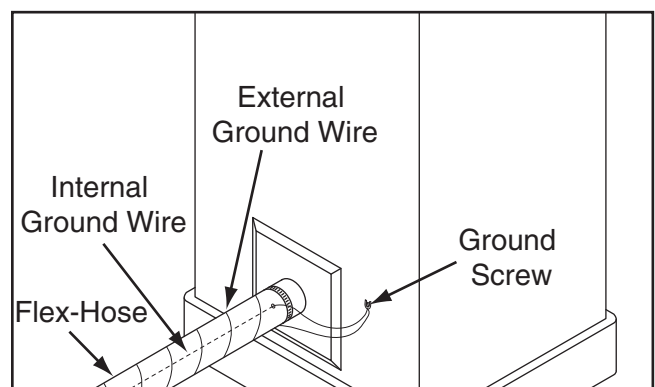

Figure 78. Flex-hose grounded to machine.



SECTION 5: ACCESSORIES

H5293—4" Metal Duct Starter Kit

H5295—5" Metal Duct Starter Kit

H5297—6" Metal Duct Starter Kit

Save over 20% with this great starter kit. Includes: (2) machine adapters, (10) pipe clamps, (3) 5' straight pipes, (1) branch, (3) pipe hangers, (1) end cap, (3) adjustable nipples, (1) 90° elbow, and (1) 60° elbow.

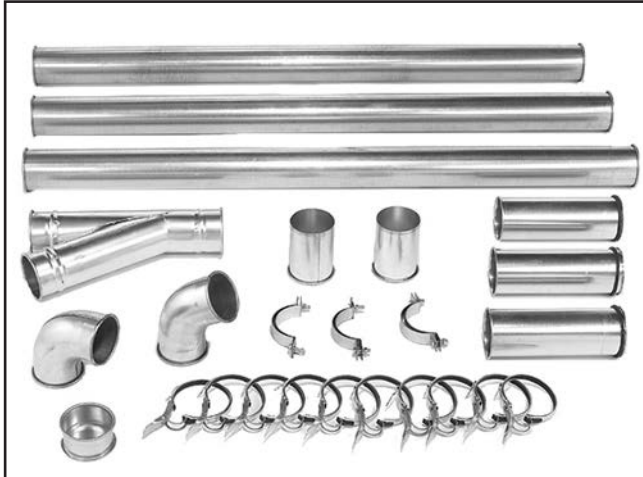

Figure 79. Metal Duct Starter Kit.

H5294—4" Metal Duct Machine Addition Kit

H5296—5" Metal Duct Machine Addition Kit

H5298—6" Metal Duct Machine Addition Kit

Save over 20% with this great machine addition kit. Includes: (2) blast gates, (1) machine adapter, (10) pipe clamps, (2) pipe hangers, (2) 5' straight pipes, (2) adjustable nipples, (1) branch, and (1) 60° elbow.

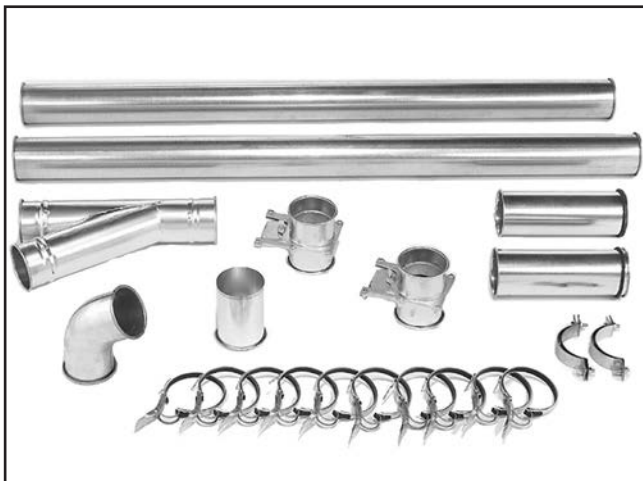

Figure 80. Metal Duct Machine Addition Kit.

G6162—4" x 5' Straight Metal Pipe

G7346—5" x 5' Straight Metal Pipe

G7364—6" x 5' Straight Metal Pipe

H5227—7" x 5' Straight Metal Pipe

H5237—8" x 5' Straight Metal Pipe

H5252—9" x 5' Straight Metal Pipe

These laser welded straight pipes ensure a super smooth internal seam. Ends easily clamp together for a sealed fit without screws or silicone.



Figure 81. Straight Metal Pipe.

H7216—5" x 5' Rigid Metal Flex Hose

H7217—6" x 5' Rigid Metal Flex Hose

H7218—7" x 5' Rigid Metal Flex Hose

H7219—8" x 5' Rigid Metal Flex Hose

H7220—9" x 5' Rigid Metal Flex Hose

This flex hose provides just enough flexibility to make difficult connections while still keeping the inside wall as smooth as possible to minimize static pressure loss.

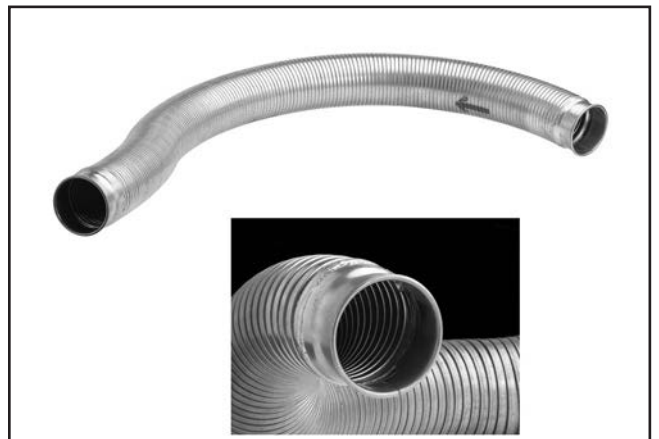

Figure 82. Rigid Metal Flex Hose.



Metal Elbows

These industrial metal elbows are available from 4"–8" with 90°, 60°, 45°, or 30° curves. Also, available with a 90° long radius curve. Call (800) 523-4777 or visit www.grizzly.com for more information and pricing.

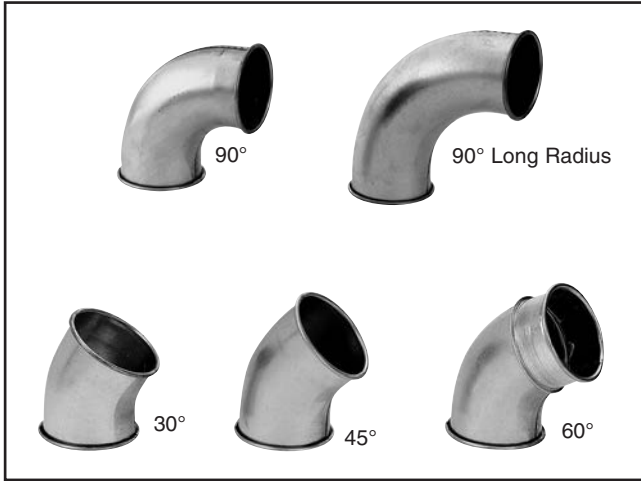

Figure 83. Metal elbow examples.

- G6177—4" Metal Blast Gate
- G7340—5" Metal Blast Gate
- G7358—6" Metal Blast Gate
- H5234—7" Metal Blast Gate
- H5249—8" Metal Blast Gate
- H5259—9" Metal Blast Gate



Figure 84. Metal Blast Gate.

Call 1-800-523-4777 To Order

Metal Branches

We carry many different branches, all designed to minimize airflow resistance.



Figure 85. Metal Branches.

Reducers & Adapters

We carry a multitude of reducers and elbows to cover most applications from 4" through 9".



Figure 86. Metal Reducers & Adapters.

- G6252—4" Floor Sweep
- G7341—5" Floor Sweep
- G7342—6" Floor Sweep

Great for cleaning up around the shop, these metal floor sweeps close tight when not in use.



Figure 87. Industrial Floor Sweep.



SECTION 6: OPERATIONS

Operation Safety

! WARNING

Damage to your eyes, lungs, and ears could result from using this machine without proper protective gear. Always wear safety glasses, a respirator, and hearing protection when operating this machine.

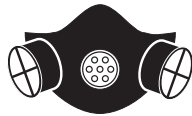

! WARNING

Do NOT put hands or small objects near inlet openings during operation. Objects sucked into the inlet will meet with the impeller blade. Failure to heed this warning could result in property damage or personal injury.

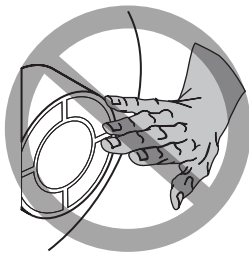

! CAUTION

DO NOT use the dust collector for any other purpose besides collecting dust from connected woodworking machines. A dust collector should NEVER be used as a shop vacuum and IS NOT a substitute for an air filter system. For safest use, wear a respirator and use an air cleaner in addition to the dust collector.

NOTICE

If you have never used this type of machine or equipment before, WE STRONGLY RECOMMEND that you read books, trade magazines, or get formal training before beginning any projects. Regardless of the content in this section, Grizzly Industrial will not be held liable for accidents caused by lack of training.

General

Operating your Model G0637/G0638 is simple and straightforward. Blast gates located at each of the machines controls the air flow from the woodworking machine to the dust collector. If a machine is not being used, keep the blast gate closed to maintain higher levels of efficiency throughout the system.

Remote Control

The remote control for the Model G0637/G0638 is IR (infrared) rather than RF (radio frequency) to prevent accidental startups by other common RF items like garage door openers.

Because this remote system is IR, the remote control must be pointing directly at the control box with an unobstructed line-of-sight view.

If you place your dust collector in a different room or outside of your shop, you must mount the switch in the shop and wire it through the wall to the dust collector to make use of the remote control.



SECTION 7: MAINTENANCE

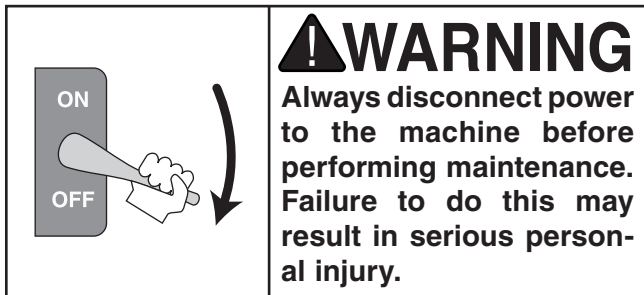

Schedule

For optimum performance from your machine, follow this maintenance schedule and refer to any specific instructions given in this section.

Daily Check:

- Dust collector is completely powered down at the end of use.
- Dust collection drums and bags.
- Loose mounting bolts.
- Pressure leaks.
- Worn or damaged wires.
- Any other condition that would hamper the safe and efficient operation of this machine.

Emptying Drums

Empty the collection drums when they are $\frac{3}{4}$ full or less. If the drums become overfilled, the dust will be sucked into the intake barrel and passed through to the canister filters.

How quickly the drum will fill up is based on the type of work being done at the time:

- Fine dust from a sander or table saw will slowly fill the drums.
- Curly shavings from a planer or jointer will quickly fill the drums.

In the beginning, check your drums regularly to get an idea of how often they need to be emptied.

Cleaning Filters

The Model G0637/G0638 dust collector has a gentle brush system inside the canisters for removing any built-up dust from the filter pleats.

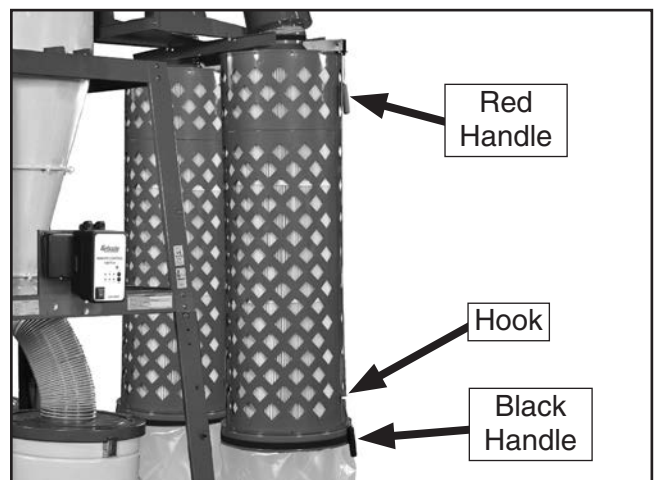
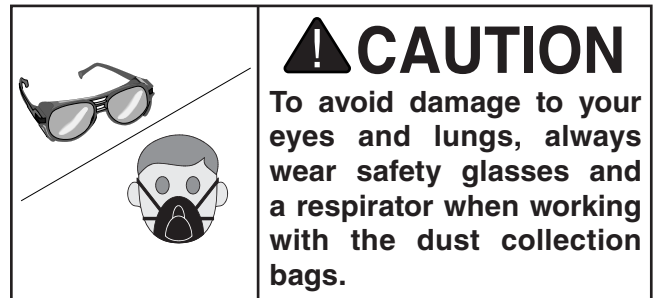

Figure 88. Brush handles for cleaning canister filters.

To clean the filters, pull the red handles down all the way, then pull the black handles down and hook them in place.

Note: Always make sure to leave the red handles in the up position to ensure that the brushes return to their proper position and do not restrict the filter.



Rinsing Filter

For a thorough cleaning, the filter can be removed and rinsed off. However, make sure to clean the filter with the brush system first. Allow the filter to air dry, but never leave the filter in the sun to dry or it could become damaged.

Removing/Replacing Filter

The filter for canister filter assemblies manufactured since November, 2009, can be removed from the assembly so that it can be replaced or rinsed off (see the instructions in the next subsection).

Removing/installing the filter requires removing the canister filter assembly from the dust collector and disassembling it. Follow the instructions below to perform this procedure.

Refer to the parts breakdown diagrams and listings beginning on **Page 60** to order the correct filter from Grizzly at (800) 523-4777.

Tools Needed	Qty
Open-End Wrench 10mm.....	1
Wrench or Socket 12mm.....	2

To replace the canister filter:

1. DISCONNECT MACHINE FROM POWER!
2. Remove the bag clamp and collection bag from the canister assembly.

3. Pull the black handle all the way down and secure the cable into the handle hook at the bottom of the canister assembly, as shown in **Figure 89**, to hold it in place during the following steps.

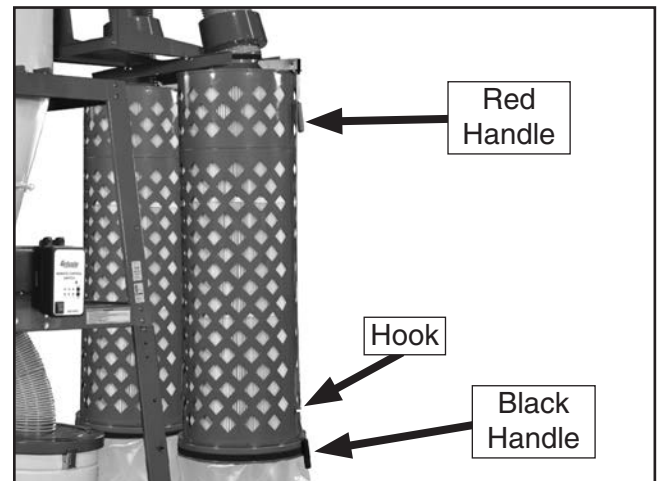

Figure 89. Black handle cable secured in the handle hook.

4. Remove the canister assembly from the dust collector and place it right-side up on a stable, flat surface.
5. Remove the six hex bolts, hex nuts, and flat washers from the rim of the canister base, as shown in **Figure 90**.

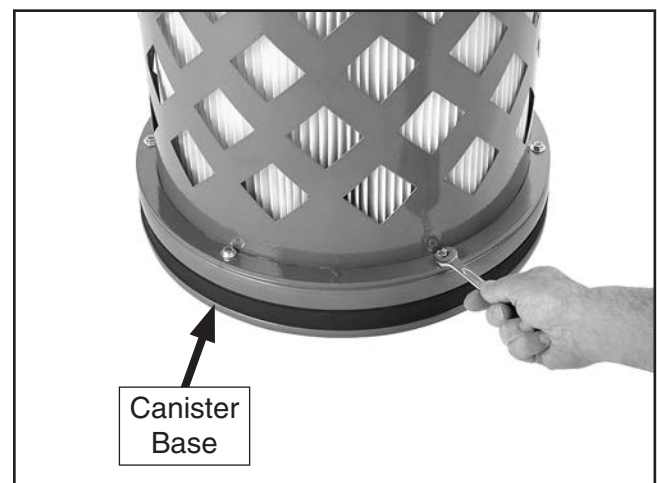

Figure 90. Removing the hex nuts and flat washers from the rim of the canister base.



6. With help from another person to steady the canister assembly, turn it upside down and remove the two M8-1.25 x 20mm hex bolts, hex nuts, and flat washers from the cross support (see **Figure 91**), then remove the canister base from the assembly.

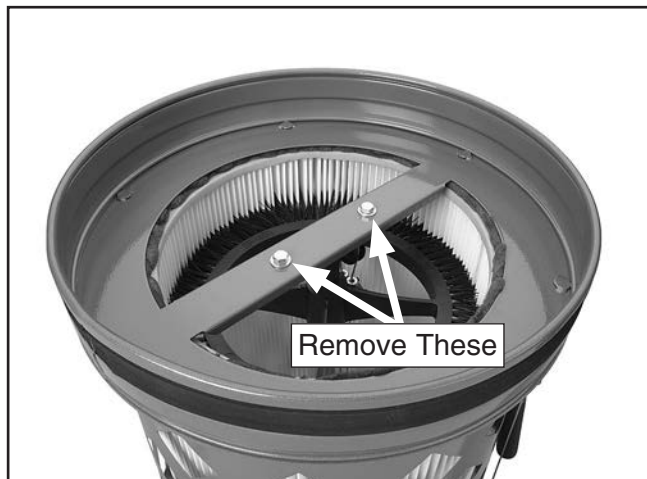

Figure 91. Cross support fasteners.

7. Carefully lift the filter from the canister assembly, as shown in **Figure 92**.



Figure 92. Removing the filter from the canister assembly.

8. Before re-inserting a filter into the assembly, make sure that the filter brush base is aligned with two of the fastener holes around the base of the assembly (see **Figure 93**). This will allow the canister base to align with the fastener holes around the brush base.



Figure 93. Filter brush base aligned with assembly fastener holes.

9. Re-insert a filter into the canister assembly.

Note: *Make sure the bristles of the brush are straight to ensure efficient cleaning of the filter when needed.*

10. Re-attach the canister base in the reverse order that you removed it.
11. Re-attach the canister assembly to the dust collector, then re-install a fresh collection bag with the bag clamp.



SECTION 8: SERVICE

Review the troubleshooting and procedures in this section if a problem develops with your machine. If you need replacement parts or additional help with a procedure, call our Technical Support at (570) 546-9663.

Note: Please gather the serial number and manufacture date of your machine before calling.

Troubleshooting

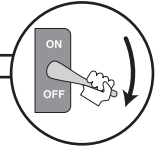

Motor & Electrical

Symptom	Possible Cause	Possible Solution
Machine does not start or a breaker trips.	<ol style="list-style-type: none"> 1. Fuse has blown. 2. Emergency stop push-button is engaged/faulty (G0638 only). 3. Hand-held remote controller is at fault. 4. Receiver is at fault. 5. Motor connection wired incorrectly. 6. Wall fuse/circuit breaker is blown/tripped. 7. Thermal overload relay has tripped. 8. Contactor not getting energized/has burnt contacts. 9. Power supply switched OFF or is at fault. 10. Wiring is open/has high resistance. 11. Motor ON button or ON/OFF switch is at fault. 12. Emergency stop push-panel is stuck/switch is at fault. 13. Transformer is at fault. 14. Computer board is at fault. 15. Inverter/control box is at fault. 16. Motor is at fault. 17. Start delay module is at fault. 	<ol style="list-style-type: none"> 1. Correct short/replace fuse in control box. 2. Rotate clockwise slightly until it pops out/replace it. 3. Replace batteries in hand-held remote controller; stay in line-of-sight view and signal range. 4. Inspect receiver computer board; replace if faulty. 5. Correct motor wiring connections (Pages 56 & 59). 6. Ensure circuit size is suitable for this machine; replace weak breaker. 7. Turn cut-out dial to increase working amps and push the reset pin. Replace if tripped multiple times (weak relay). 8. Test for power on all legs and contactor operation. Replace unit if faulty. 9. Ensure power supply is switched on; ensure power supply has the correct voltage. 10. Check for broken wires or disconnected/corroded connections, and repair/replace as necessary. 11. Replace faulty ON button or ON/OFF switch. 12. Free push-panel from binding; replace faulty switch. 13. Replace transformer. Refer to Pages 14 and 52 for more detailed information. 14. Inspect computer board; replace if faulty. 15. Inspect inverter/control box; replace if faulty. 16. Test/repair/replace. 17. Adjust to correct delay; replace module.
Machine has vibration or noisy operation.	<ol style="list-style-type: none"> 1. Motor or component is loose. 2. Motor mount loose/broken. 3. Machine is incorrectly mounted or sits unevenly. 4. Motor fan is rubbing on fan cover. 5. Motor bearings are at fault. 	<ol style="list-style-type: none"> 1. Inspect/replace stripped or damaged bolts/nuts, and re-tighten with thread locking fluid. 2. Tighten/replace. 3. Tighten/replace anchor studs in floor; relocate/shim machine. 4. Replace dented fan cover; replace loose/damaged fan. 5. Test by rotating shaft; rotational grinding/loose shaft requires bearing replacement.



Dust Collector Operation

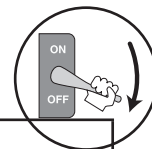

Symptom	Possible Cause	Possible Solution
Loud, repetitious noise, or excessive vibration coming from dust collector.	<ol style="list-style-type: none"> 1. Dust collector is not on a flat surface and wobbles. 2. Impeller is damaged and unbalanced. 3. The motor mounting or housing connections are loose. 4. Impeller is loose on the motor shaft. 5. Motor fan cover is dented, causing the motor fan to hit the cover while spinning. 	<ol style="list-style-type: none"> 1. Stabilize the dust collector. 2. Disconnect dust collector from power, and inspect the impeller for dents, bends, loose fins. Replace impeller if any damage is found. 3. Make sure all fasteners on the dust collector are tight. 4. Replace the motor and impeller as a set if the motor shaft and the impeller hub are damaged. 5. Replace motor fan cover.
Dust collector does not adequately collect dust or chips; poor performance.	<ol style="list-style-type: none"> 1. Dust collection bags are full. 2. Filter is dirty. 3. There is a restriction in the duct line. 4. The dust collector is too far away from the point of suction, or there are too many sharp bends in the ducting. 5. The lumber is wet and dust is not flowing through the ducting smoothly. 6. There is a leak in the ducting, or a series of small leaks, or too many open ports. 7. There are not enough open branch lines at one time, thereby causing a velocity drop in the main line. 8. The ducting and ports are incorrectly sized. 9. The machine dust collection design is inadequate. 10. The dust collector is too small for the dust collection system. 	<ol style="list-style-type: none"> 1. Empty collection bags. 2. Clean filter. 3. Remove dust line from dust collector inlet and unblock the restriction in the duct line. A plumbing snake may be necessary. 4. Relocate the dust collector closer to the point of suction, and rework ducting without sharp bends. Refer to Designing the System, beginning on Page 35. 5. Process lumber with less than 20% moisture content. 6. Rework the ducting to eliminate all leaks. Close dust ports for lines not being used. Refer to Designing the System beginning on Page 35 for more solutions. 7. Open 1 or 2 more blast gates to different branch lines to allow the velocity in the main line to increase. 8. Reinstall correctly sized ducts and fittings. Refer to Designing the System beginning on Page 35 for more solutions. 9. Use a dust collection nozzle on a stand. 10. Install a larger dust collector to power your dust collection system.
Sawdust being blown into the air from the dust collector.	<ol style="list-style-type: none"> 1. Duct clamps or dust collection bags are not properly clamped and secured. 2. Cylinder or funnel seals are loose or damaged. 	<ol style="list-style-type: none"> 1. Re-secure ducts and dust collection bag, making sure duct and bag clamps are tight and completely over the ducts and bags. 2. Retighten all mounting and sealing points, replace damaged gaskets.



SECTION 8: WIRING

These pages are current at the time of printing. However, in the spirit of improvement, we may make changes to the electrical systems of future machines. Compare the manufacture date of your machine to the one stated in this manual, and study this section carefully.

If there are differences between your machine and what is shown in this section, call Technical Support at (570) 546-9663 for assistance BEFORE making any changes to the wiring on your machine. An updated wiring diagram may be available. **Note:** *Please gather the serial number and manufacture date of your machine before calling. This information can be found on the main machine label.*

WARNING

Wiring Safety Instructions

SHOCK HAZARD. Working on wiring that is connected to a power source is extremely dangerous. Touching electrified parts will result in personal injury including but not limited to severe burns, electrocution, or death. Disconnect the power from the machine before servicing electrical components!

MODIFICATIONS. Modifying the wiring beyond what is shown in the diagram may lead to unpredictable results, including serious injury or fire. This includes the installation of unapproved after-market parts.

WIRE CONNECTIONS. All connections must be tight to prevent wires from loosening during machine operation. Double-check all wires disconnected or connected during any wiring task to ensure tight connections.

CIRCUIT REQUIREMENTS. You MUST follow the requirements at the beginning of this manual when connecting your machine to a power source.

WIRE/COMPONENT DAMAGE. Damaged wires or components increase the risk of serious personal injury, fire, or machine damage. If you notice that any wires or components are damaged while performing a wiring task, replace those wires or components.

MOTOR WIRING. The motor wiring shown in these diagrams is current at the time of printing but may not match your machine. If you find this to be the case, use the wiring diagram inside the motor junction box.















CAPACITORS/INVERTERS. Some capacitors and power inverters store an electrical charge for up to 10 minutes after being disconnected from the power source. To reduce the risk of being shocked, wait at least this long before working on capacitors.

EXPERIENCING DIFFICULTIES. If you are experiencing difficulties understanding the information included in this section, contact our Technical Support at (570) 546-9663.

NOTICE

The photos and diagrams included in this section are best viewed in color. You can view these pages in color at www.grizzly.com.

COLOR KEY

BLACK		BLUE		YELLOW		LIGHT BLUE	
WHITE		BROWN		YELLOW GREEN		BLUE WHITE	
GREEN		GRAY		PURPLE		TURQUOISE	
RED		ORANGE		PINK			



G0637 Electrical Components

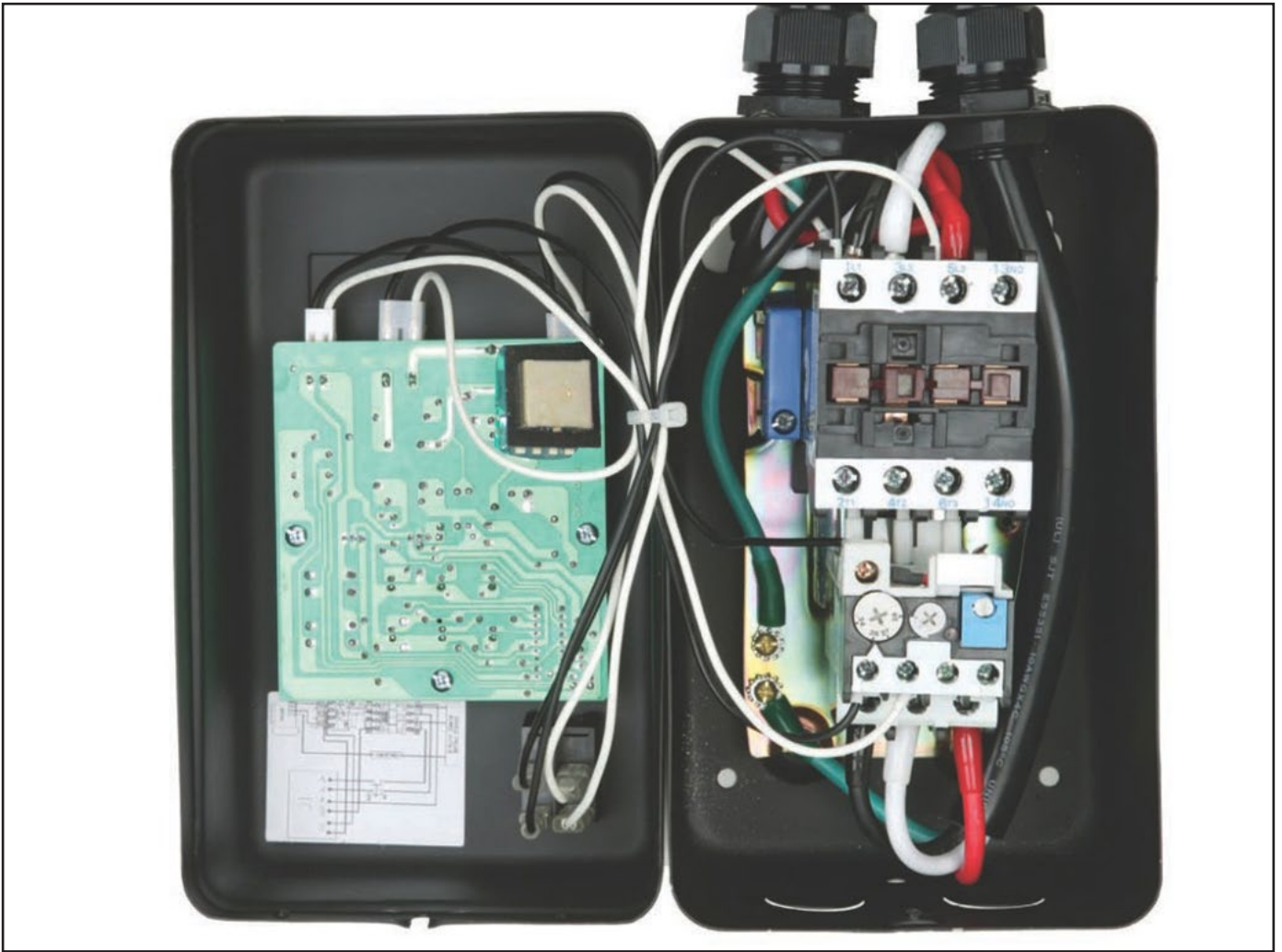

Figure 94. Model G0637 control box.



Figure 95. Model G0637 motor wiring (220V).

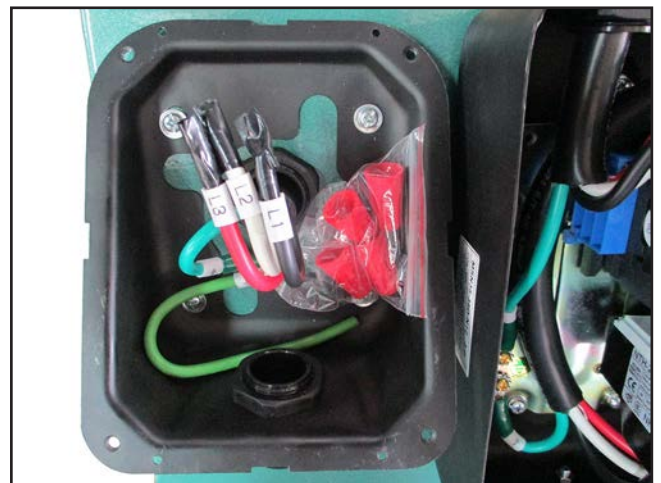

Figure 96. Model G0637 junction box wiring.



G0637 Control Box 220 VAC Wiring Diagram



NOTICE
If connecting machine to a phase converter, the manufactured leg must be connected to terminal 3L/2.

NOTICE
If motor rotates in opposite direction, swap any two power source wires at the incoming terminals.

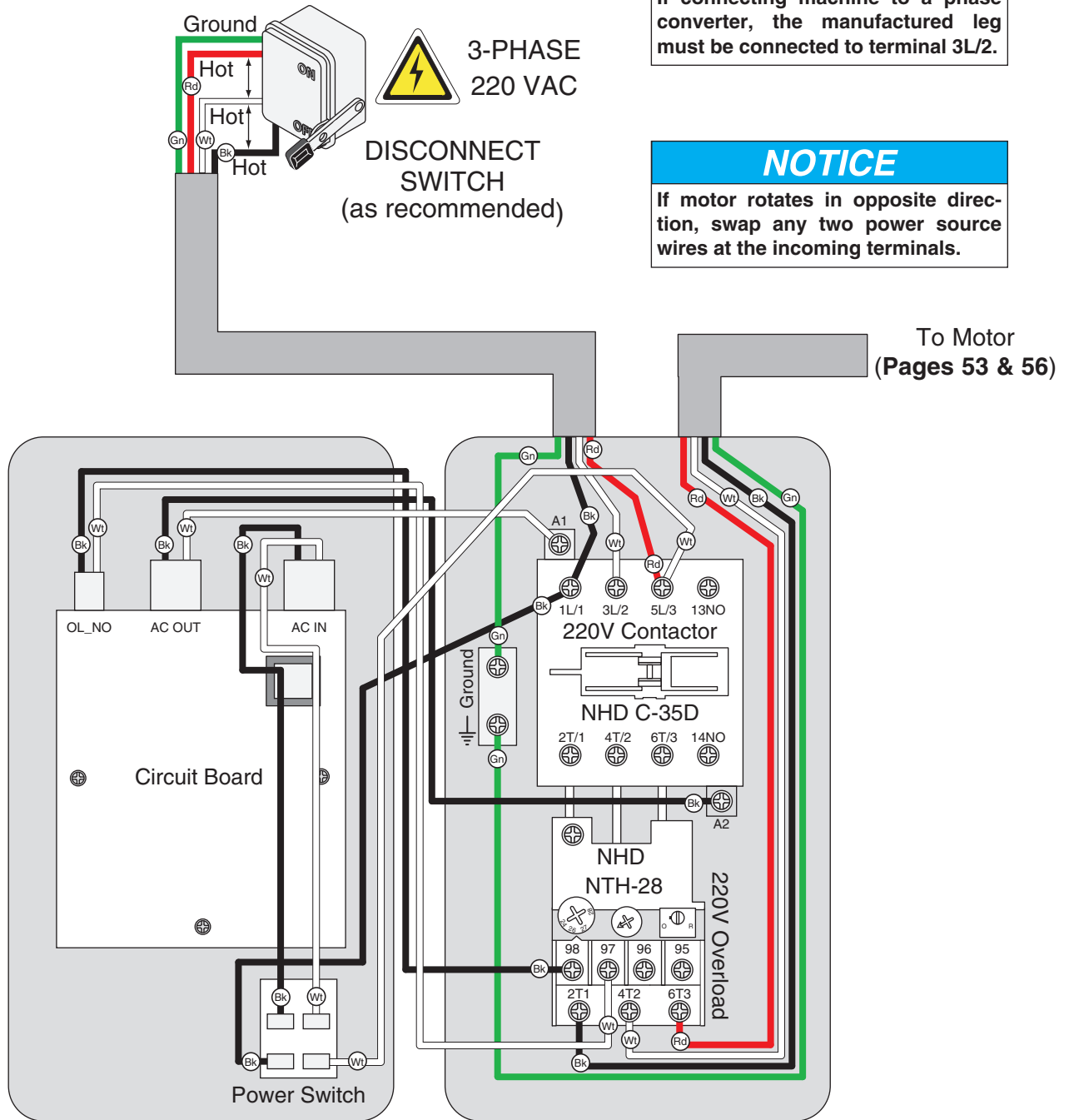

G0637 440V Wiring Diagram

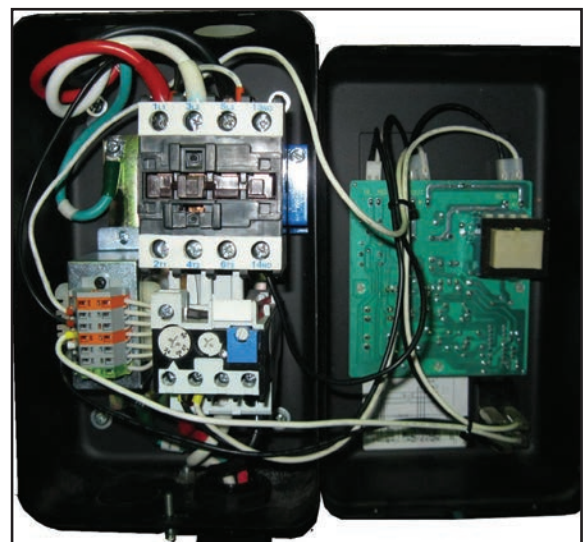
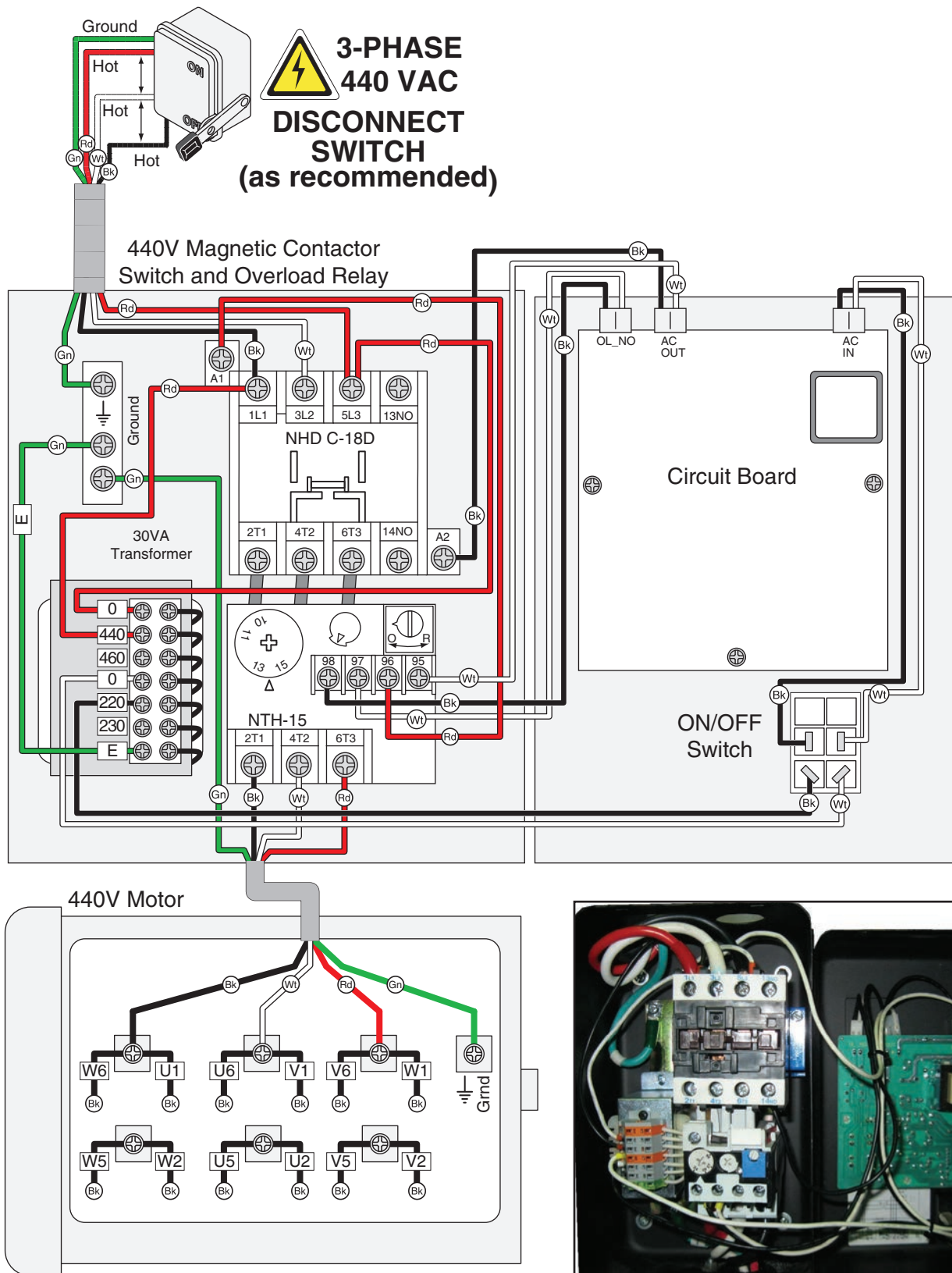
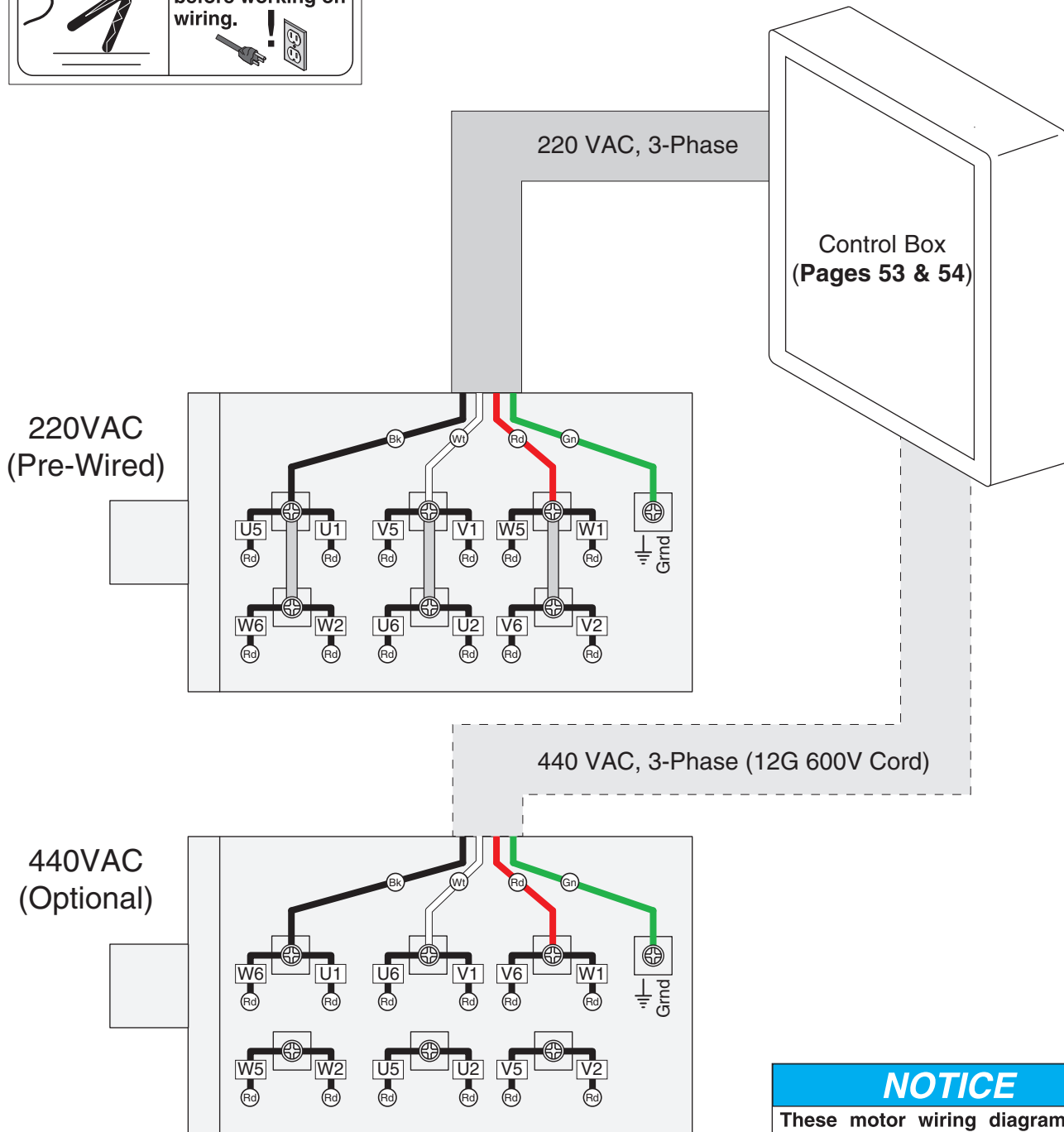

Figure 97. G0637 440V control box wiring.



G0637 Motor Wiring Diagram (220V/440V)



When rewiring to 440V, you must purchase and install the 440V Conversion Kit. Refer to **Page 145** for details.

NOTICE
These motor wiring diagrams are current at the time of printing; however, always use the diagram on the inside of the junction box cover when rewiring your motor!



G0638 Electrical Components

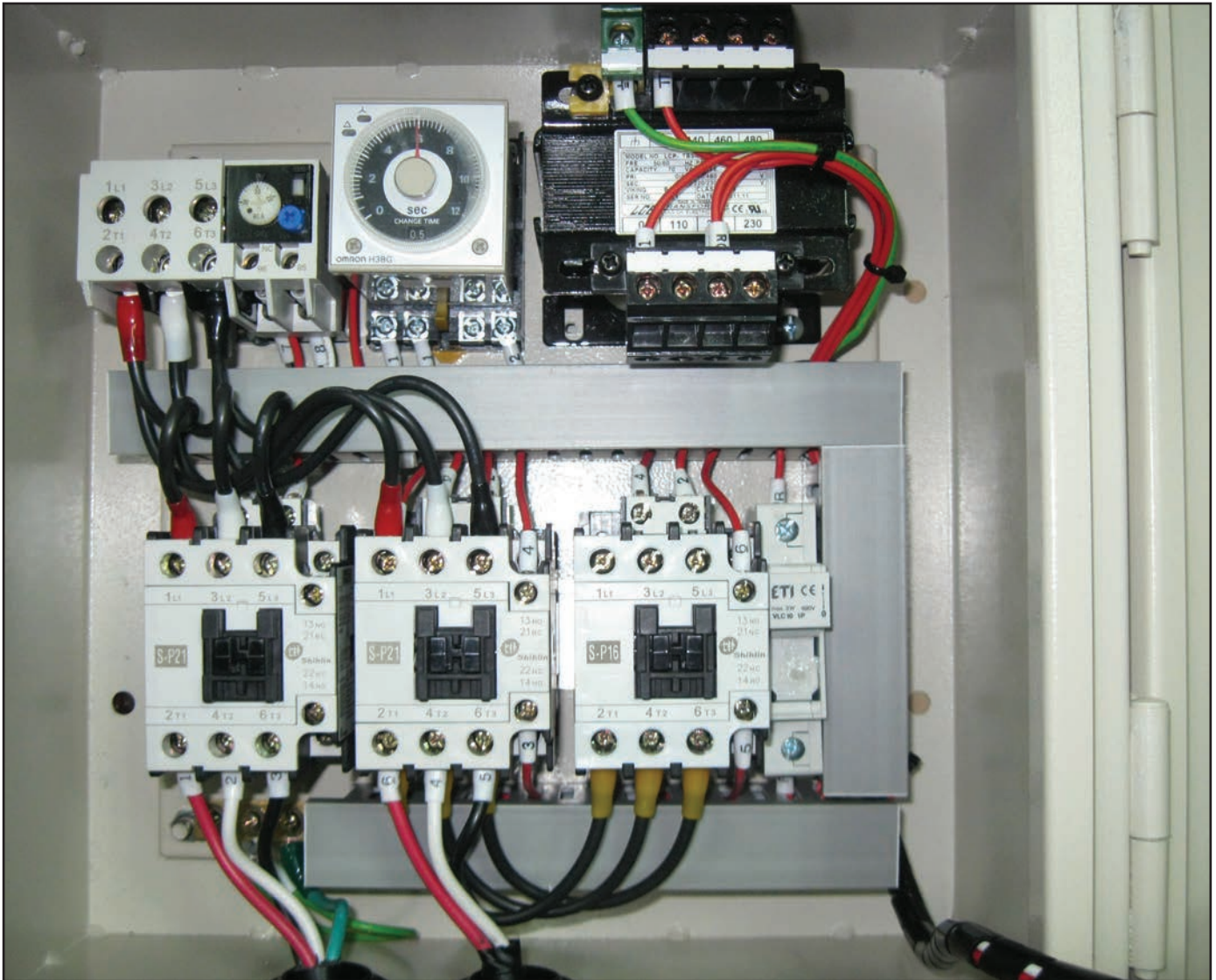

Figure 98. Model G0638 control box.

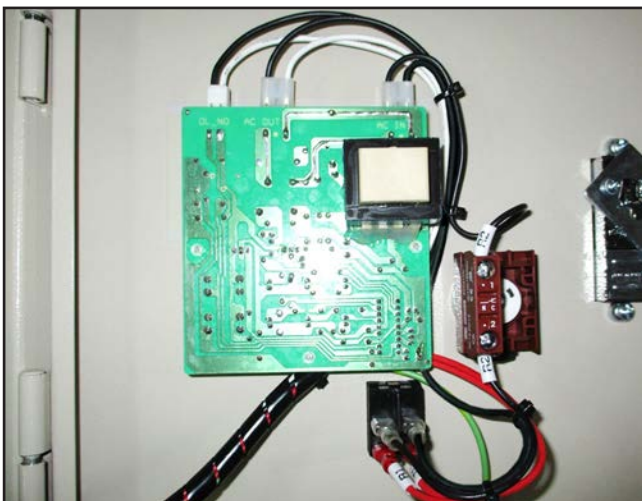

Figure 99. Model G0638 control box cover (shown from back).



Figure 100. Model G0638 motor wiring (220V).



G0638 Control Box 220 VAC Wiring Diagram



NOTICE
If connecting machine to a phase converter, the manufactured leg must be connected to terminal 3L/2.

NOTICE
If motor rotates in opposite direction, swap any two power source wires at the incoming terminals.

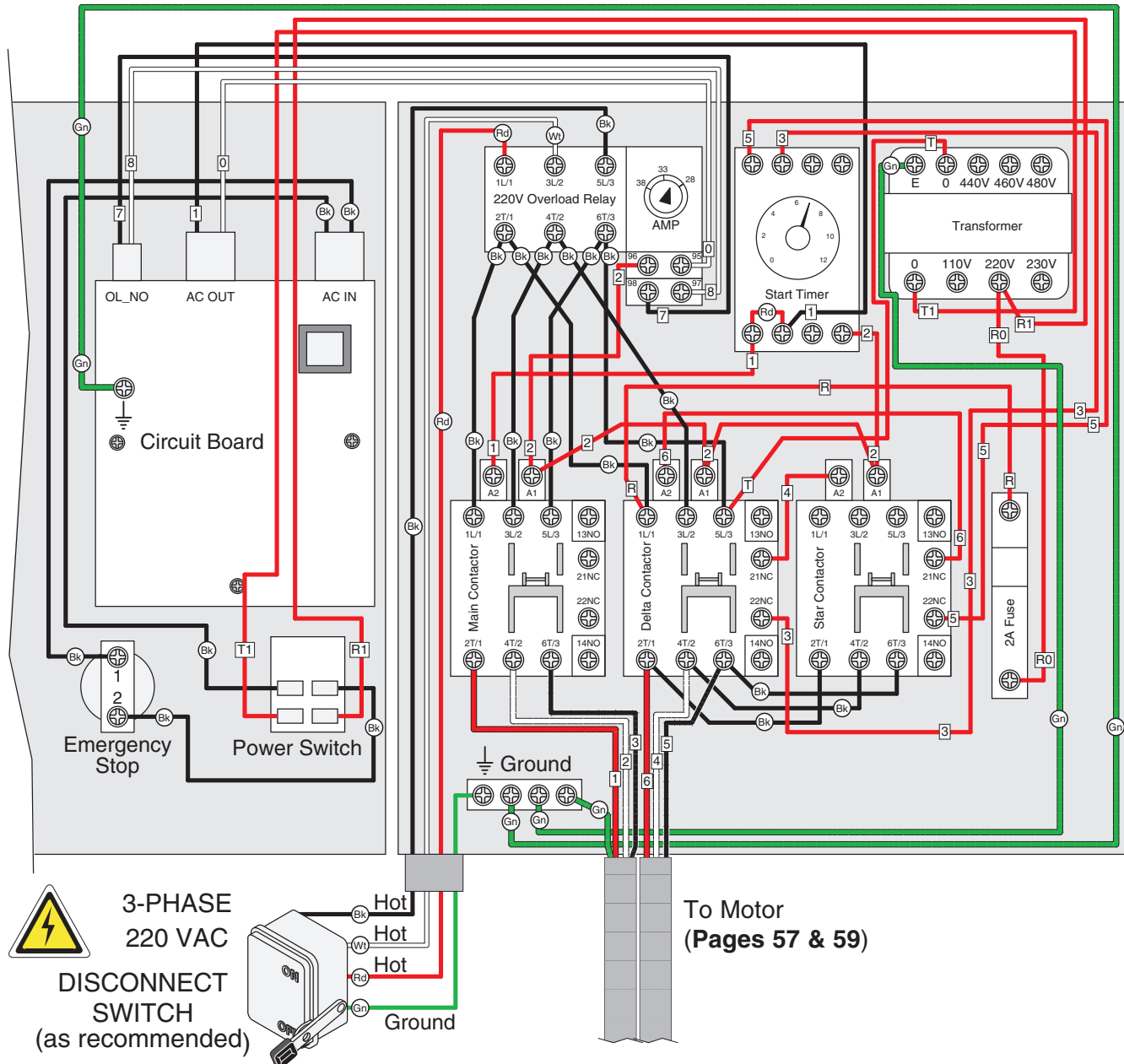

G0638 Motor Wiring Diagram (220V/440V)

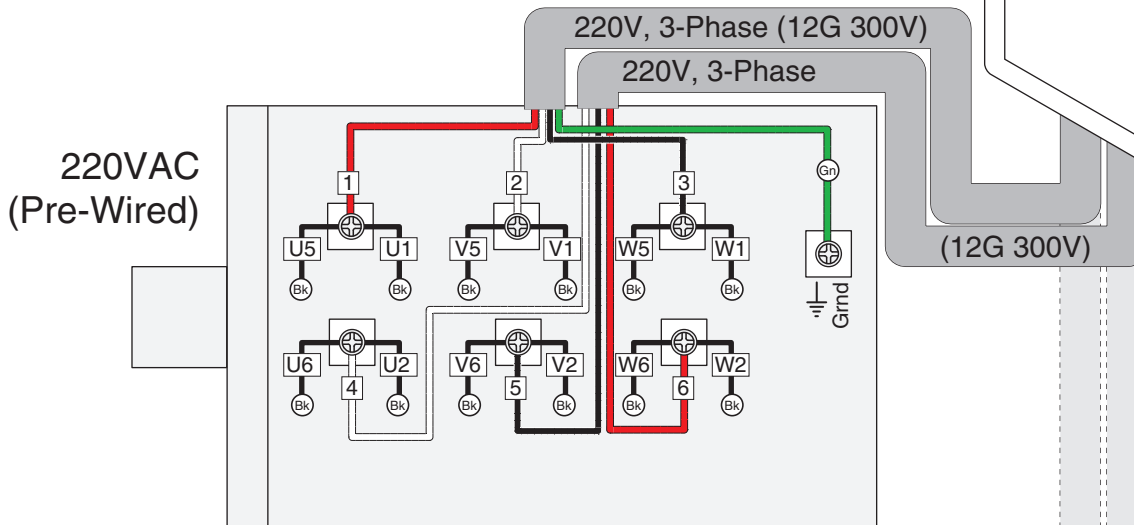
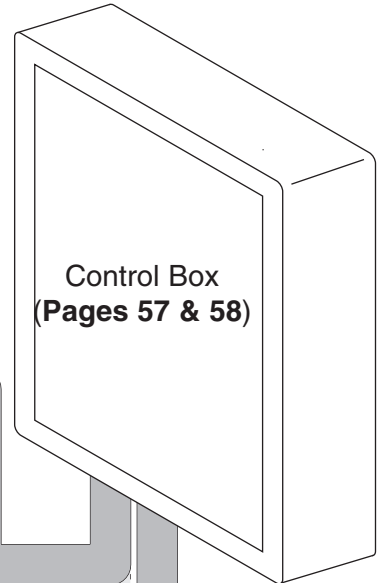

When rewiring to 440V, you must purchase and install the 440V Conversion Kit. Refer to **Page 14** for details.

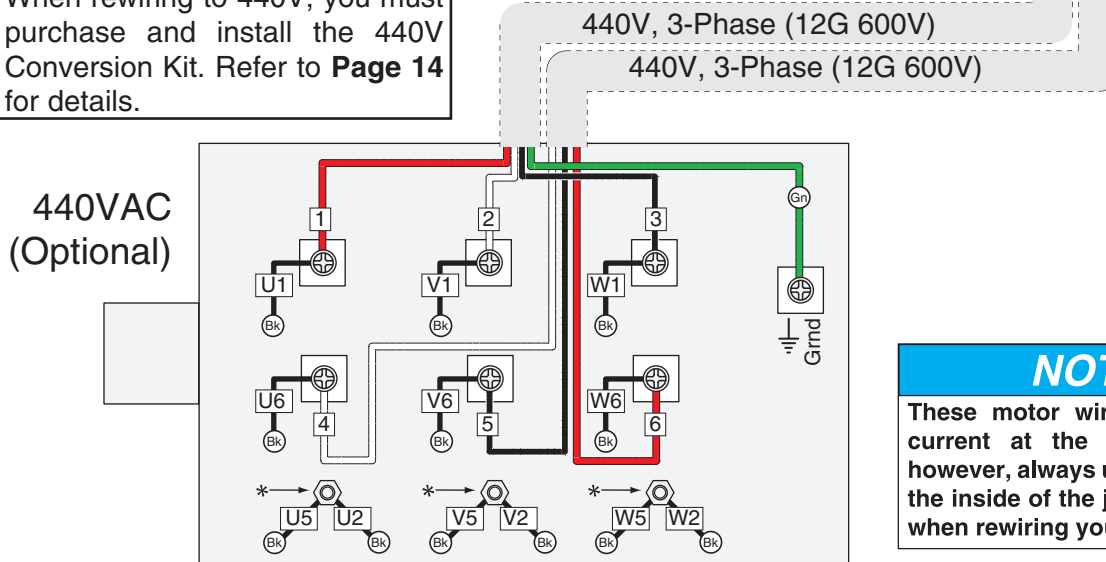

NOTICE

These motor wiring diagrams are current at the time of printing; however, always use the diagram on the inside of the junction box cover when rewiring your motor!

* Safely cover wire connections with electrical tape



SECTION 10: PARTS

Parts Breakdown

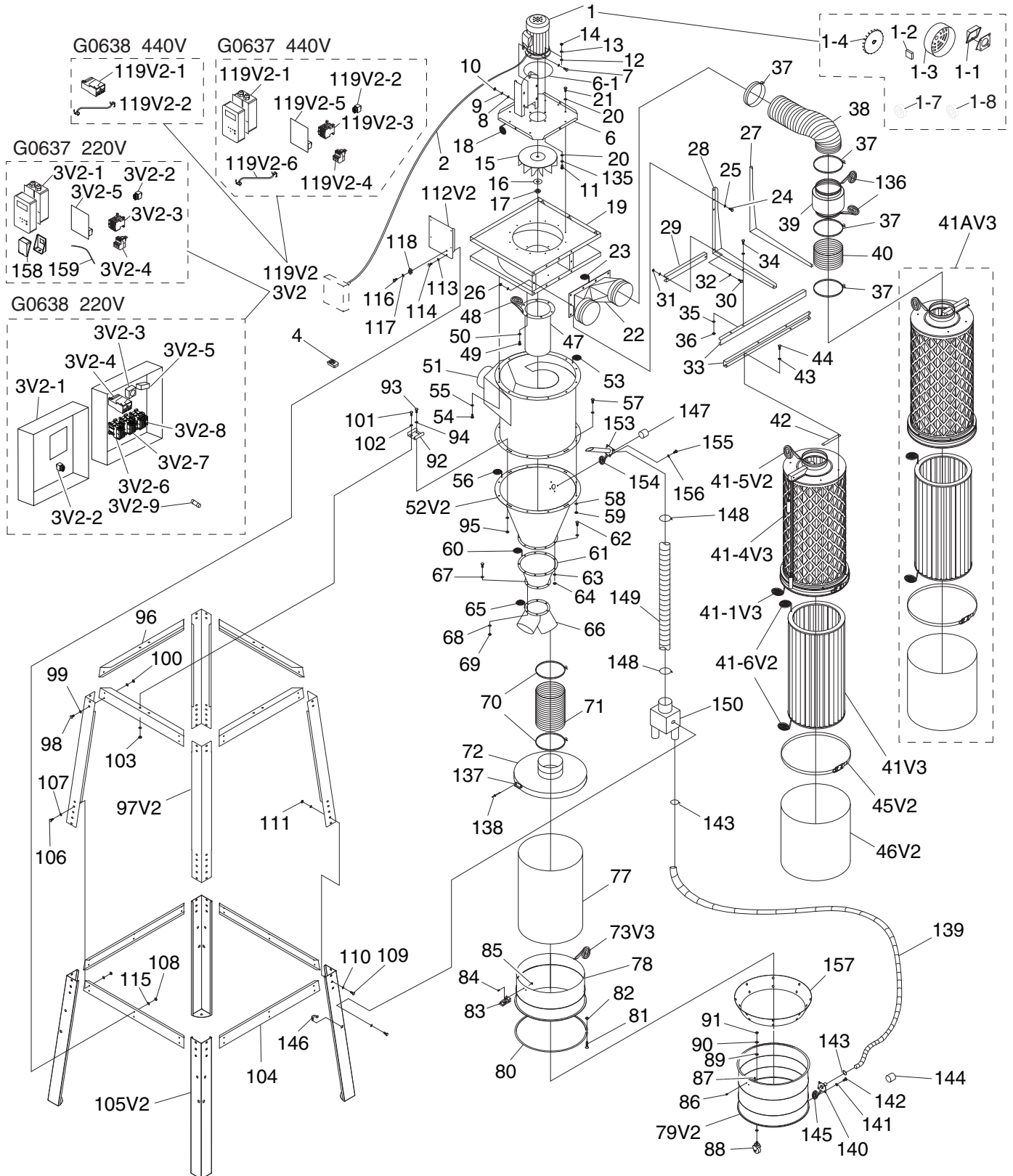

G0637 Only Parts List

REF	PART #	DESCRIPTION
1	P0637001	MOTOR 7-1/2HP 220/440V 3-PH
1-1	P0637001-1	MOTOR JUNCTION BOX
1-2	P0637001-2	MOTOR JUNCTION BLOCK
1-3	P0637001-3	MOTOR FAN COVER
1-4	P0637001-4	MOTOR FAN
1-7	P0637001-7	FRONT MOTOR BEARING
1-8	P0637001-8	REAR MOTOR BEARING
2	P0637002	MOTOR CORD 10G 4W 300V
3V2	P0637003V2	MAG SWITCH ASSY V2.01.12
3V2-1	P0637003V2-1	MAGNETIC SWITCH COVER
3V2-2	P0637003V2-2	POWER SWITCH
3V2-3	P0637003V2-3	CONTACTOR NHD C-35D 220V
3V2-4	P0637003V2-4	OL RELAY NHD NTH-28 24-28A
3V2-5	P0637003V2-5	CIRCUIT BOARD W/TRANSFORMER
6	P0637006	MOTOR BASE
6-1	P0637006-1	MOTOR GASKET
15	P0637015	IMPELLER 18"
16	P0637016	FLAT WASHER 3/4

REF	PART #	DESCRIPTION
17	P0637017	HEX NUT 3/4-16 LH
41AV3	P0637041AV3	CANISTER ASSEMBLY, BEIGE V3.07.12
41V2	P0637041V2	CANISTER FILTER 486 X 1195MM V2.11.09
41-4V3	P0637041-4V3	CANISTER CAGE ASSY, BEIGE V3.07.12
112V2	P0637112V2	CONTROL BOX BRACKET CSA V2.01.12
116	P0637116	PHLP HD SCR 10-24 X 3/8
117	P0637117	FLAT WASHER #10
118	P0637118	HEX NUT 10-24
119V2	P0637119V2	CONVERSION KIT 440V V2.01.12
119V2-1	P0637119V2-1	MAGNETIC SWITCH COVER
119V2-2	P0637119V2-2	POWER SWITCH
119V2-3	P0637119V2-3	CONTACTOR MSN35-18D
119V2-4	P0637119V2-4	OL RELAY NHD NTH-15 10-15A
119V2-5	P0637119V2-5	CIRCUIT BOARD W/TRANSFORMER
119V2-6	P0637119V2-6	MOTOR CORD 12G 4W 600V
119V2-7	P0637119V2-7	SWITCH TRANSFORMER 30VA
158	P0637158	JUNCTION BOX
159	P0637159	GREEN GROUNDING WIRE 10G 6"

G0638 Only Parts List

REF	PART #	DESCRIPTION
1	P0638001	MOTOR 10HP 220/440V 3-PH
1-1	P0638001-1	MOTOR JUNCTION BOX
1-2	P0638001-2	MOTOR JUNCTION BLOCK
1-3	P0638001-3	MOTOR FAN COVER
1-4	P0638001-4	MOTOR FAN
1-7	P0638001-7	FRONT MOTOR BEARING
1-8	P0638001-8	REAR MOTOR BEARING
2	P0638002	MOTOR CORD 12G 4W 300V
3V2	P0638003V2	CONTROL BOX 220V V2.01.12
3V2-1	P0638003V2-1	CONT. BOX W/ CIRC BOARD
3V2-2	P0638003V2-2	POWER SWITCH 220/440V
3V2-3	P0638003V2-3	START TIMER OMRON H3BG 0-12 SEC
3V2-4	P0638003V2-4	OL RELAY SHIHLIN TH-P20 28-38 220V
3V2-5	P0638003V2-5	TRANSFORMER
3V2-6	P0638003V2-6	CONTACTOR SHIHLIN S-P21
3V2-7	P0638003V2-7	CONTACTOR SHIHLIN S-P21

REF	PART #	DESCRIPTION
3V2-9	P0638003V2-9	FUSE 2AMP
6	P0638006	MOTOR BASE
6-1	P0638006-1	MOTOR GASKET
15	P0638015	IMPELLER 18-1/2"
16	PW19	FLAT WASHER 1-1/6
17	PN44	HEX NUT 1-1/16-8
41AV3	P0638041AV3	CANISTER ASSEMBLY, BEIGE V3.07.12
41V3	T24781	CANISTER ASSEMBLY FOR G0638
41-4V2	P0638041-4V2	CANISTER CAGE, GREEN V2.11.09
112V2	P0638112V2	CONT. BOX BRACKET CSA V2.01.12
116	PS11M	PHLP HD SCR M6-1 X 16
117	PW06	FLAT WASHER 1/4
118	PN01M	HEX NUT M6-1
119V2	P0638119V2	CONVERSION KIT 440V V2.01.12
119V2-1	P0638119V2-1	OL RELAY SHIHLIN/TH-P20S 12-18A
119V2-2	P0638119V2-2	MOTOR CORD 12G 4W 600V

G0637/G0638 Common Parts List

REF	PART #	DESCRIPTION
4	P0637004	REMOTE CONTROLLER
7	P0637007	HEX BOLT 3/8-16 X 1-1/2
8	P0637008	FLAT WASHER 3/8
9	P0637009	LOCK WASHER 3/8
10	P0637010	HEX NUT 3/8-16
11	P0637011	HEX BOLT 1/2-13 X 1-1/2
12	P0637012	FLAT WASHER 1/2
13	P0637013	LOCK WASHER 1/2
14	P0637014	HEX NUT 1/2-13
18	P0637018	GASKET 3 X 6 X 1700MM

REF	PART #	DESCRIPTION
19	P0637019	BLOWER
20	P0637020	FLAT WASHER 5/16
21	P0637021	HEX BOLT 5/16-18 X 3/4
22	P0637022	OUTLET PORT
23	P0637023	FOAM TAPE 3 X 15 X 700MM
24	P0637024	HEX BOLT 5/16-18 X 1
25	P0637025	FLAT WASHER 5/16
26	P0637026	HEX NUT 5/16-18
27	P0637027	RIGHT FILTER L-BRACE



G0637/G0638 Common Parts List

REF	PART #	DESCRIPTION
28	P0637028	LEFT FILTER L-BRACE
29	P0637029	SHORT FILTER BRACE SUPPORT
30	P0637030	HEX BOLT 3/8-16 X 3/4
31	P0637031	HEX NUT 3/8-16
32	P0637032	FLAT WASHER 3/8
33	P0637033	LONG FILTER BRACE SUPPORT
34	P0637034	HEX BOLT 3/8-16 X 3/4
35	P0637035	FLAT WASHER 3/8
36	P0637036	HEX NUT 3/8-16
37	P0637037	HOSE CLAMP 8"
38	P0637038	FLEXIBLE DUCT 8 X 31-1/2"
39	P0637039	NOISE MUFFLER 8"
40	P0637040	FLEXIBLE DUCT 8 X 4-3/4"
41-1V2	P0637041-1V2	GASKET 3 X 25 X 1700MM V2.11.09
41-5V2	P0637041-5V2	FOAM TAPE 3 X 25 X 700MM V2.11.09
41-6V2	P0637041-6V2	GASKET 35 X 38 X 1570MM V2.11.09
42	P0637042	RUBBER BRACE GASKET
43	P0637043	FLAT WASHER 5/16
44	P0637044	HEX BOLT 5/16-18 X 3/4
45V2	P0637045V2	FILTER BAG CLAMP 545MM V2.11.09
46V2	P0637046V2	COLLECTION BAG 570 X 600MM V2.11.09
47	P0637047	INTAKE CYLINDER
48	P0637048	GASKET 3 X 6 X 1800MM
49	P0637049	HEX BOLT 5/16-18 X 3/4
50	P0637050	FLAT WASHER 5/16
51	P0637051	INTAKE BARREL
52V2	P0637052V2	LARGE CYCLONE FUNNEL V2.08.10
53	P0637053	GASKET 3 X 6 X 2500MM
54	P0637054	HEX BOLT 5/16-18 X 3/4
55	P0637055	FLAT WASHER 5/16
56	P0637056	GASKET 3 X 6 X 2500MM
57	P0637057	HEX BOLT 5/16-18 X 1-1/4
58	P0637058	FLAT WASHER 5/16
59	P0637059	HEX NUT 5/16-18
60	P0637060	GASKET 3 X 6 X 2200MM
61	P0637061	SMALL CYCLONE FUNNEL
62	P0637062	HEX BOLT 5/16-18 X 1-1/4
63	P0637063	FLAT WASHER 5/16
64	P0637064	HEX NUT 5/16-18
65	P0637065	GASKET 3 X 6 X 735MM
66	P0637066	FUNNEL PORT
67	P0637067	HEX BOLT 5/16-18 X 1-1/4
68	P0637068	FLAT WASHER 5/16
69	P0637069	HEX NUT 5/16-18
70	P0637070	HOSE CLAMP 9"
71	P0637071	FLEXIBLE DUCT 9 X 25-1/2"
72	P0637072	COLLECTION DRUM LID
73V3	P0637073V3	DRUM SEAL TYPE-R 2.1M V3.01.12
77	P0637077	DRUM COLLECTION BAG 640 X 1200MM
78	P0637078	UPPER DRUM 25GAL
79V2	P0637079V2	COLLECTION DRUM 35GAL V2.08.10
80	P0637080	DRUM CLAMP
81	P0637081	HEX BOLT 5/16-18 X 3
82	P0637082	HEX NUT 5/16-18
83	P0637083	COLLECTION DRUM LID LATCH

REF	PART #	DESCRIPTION
84	P0637084	PHLP HD SCR 10-24 X 3/8
85	P0637085	HEX NUT 10-24
86	P0637086	PHLP HD SCR 10-24 X 3/8
87	P0637087	HEX NUT 10-24
88	P0637088	CASTER 2"
89	P0637089	FLAT WASHER 3/8
90	P0637090	LOCK WASHER 3/8
91	P0637091	HEX NUT 3/8-16
92	P0637092	CYCLONE MOUNTING BRACKET
93	P0637093	HEX BOLT 3/8-16 X 1-1/4
94	P0637094	FLAT WASHER 3/8
95	P0637095	LOCK NUT 3/8-16
96	P0637096	UPPER STAND BRACE
97V2	P0637097V2	UPPER STAND LEG V2.08.10
98	P0637098	HEX BOLT 3/8-16 X 3/4
99	P0637099	FLAT WASHER 3/8
100	P0637100	LOCK NUT 3/8-16
101	P0637101	HEX BOLT 3/8-16 X 3/4
102	P0637102	FLAT WASHER 3/8
103	P0637103	LOCK NUT 3/8-16
104	P0637104	LOWER STAND BRACE
105V2	P0637105V2	LOWER STAND LEG V2.08.10
106	P0637106	HEX BOLT 3/8-16 X 3/4
107	P0637107	FLAT WASHER 3/8
108	P0637108	LOCK NUT 3/8-16
109	P0637109	HEX BOLT 3/8-16 X 3/4
110	P0637110	FLAT WASHER 3/8
111	P0637111	LOCK NUT 3/8-16
113	P0637113	HEX BOLT 3/8-16 X 3/4
114	P0637114	FLAT WASHER 3/8
115	P0637115	HEX NUT 3/8-16
135	P0637135	EXT TOOTH WASHER 1/2
136	P0637136	FOAM TAPE 3 X 15 X 700MM
137	P0637137	DRUM LID HOOK
138	P0637138	HOOK RIVET
139	P0637139	VACUUM HOSE 1-1/4" X 79"
140	P0637140	COLLECTION DRUM VACUUM PORT
141	P0637141	FLAT WASHER 5/16
142	P0637142	HEX BOLT 5/16-18 X 3/4
143	P0637143	HOSE CLAMP 1-1/4"
144	P0637144	PORT PLUG 1-1/4"
145	P0637145	FOAM TAPE 3 X 6 X 300MM
146	P0637146	VACUUM HOSE CLIP 2-1/2"
147	P0637147	PORT PLUG 2"
148	P0637148	HOSE CLAMP 2"
149	P0637149	VACUUM HOSE 2" X 39"
150	P0637150	VACUUM MANIFOLD
153	P0637153	CYCLONE VACUUM PORT
154	P0637154	FOAM TAPE 3 X 6 X 300MM
155	P0637155	HEX BOLT 5/16-18 X 3/4
156	P0637156	FLAT WASHER 5/16
157	P0637157	COLLECTION DRUM VACUUM RING
158	P0637158	JUNCTION BOX
159	P0637159	GREEN GROUNDING WIRE 10G 6"



Machine Labels

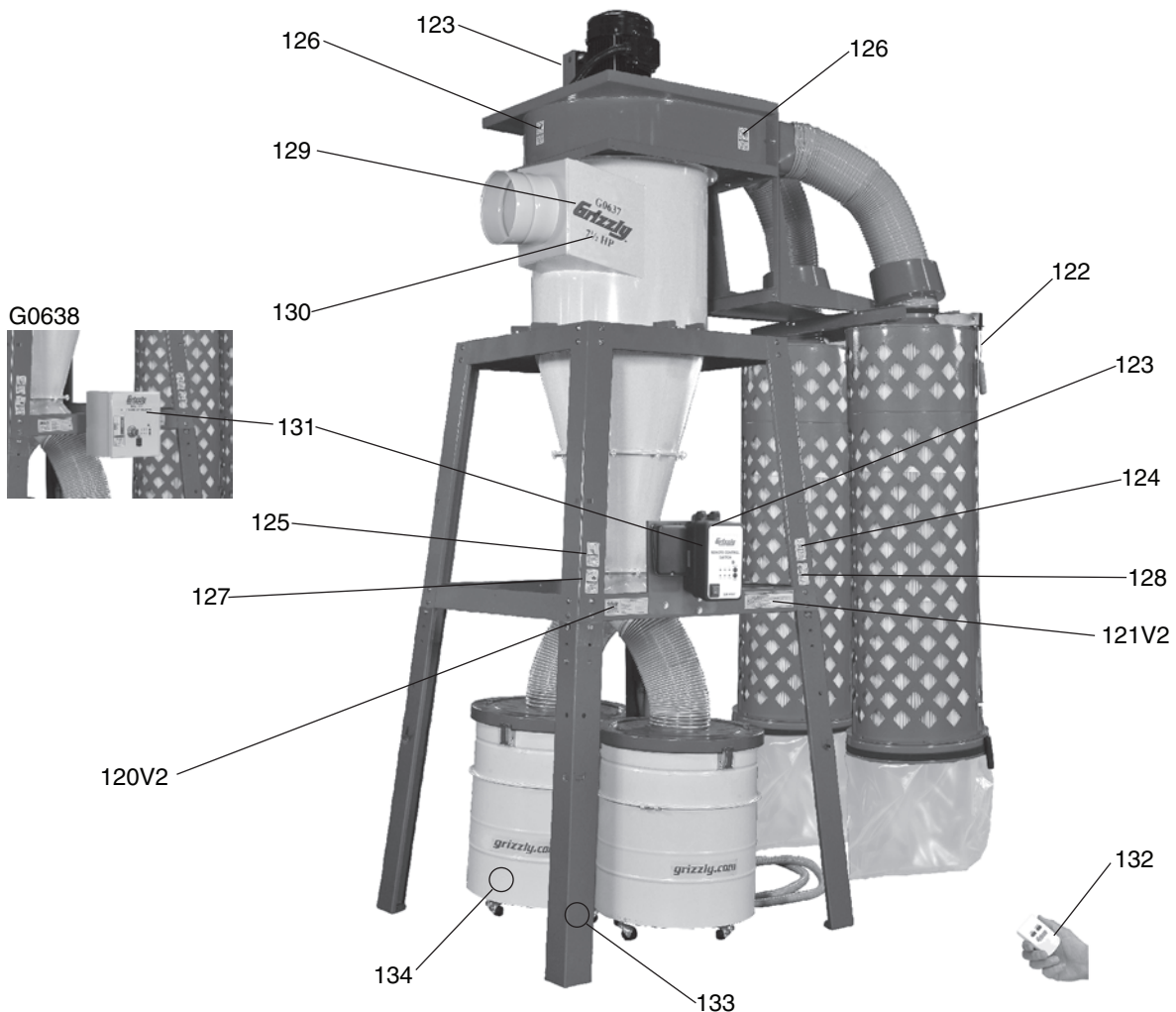

REF	PART #	DESCRIPTION
120V2	P0637120V2	MACHINE ID LABEL CSA V2.01.12
121V2	P0637121V2	GENERAL WARNING LABEL CSA V2.01.12
122	P0637122	RED HANDLE NOTICE LABEL
123	P0637123	ELECTRICITY LABEL
124	P0637124	DISCONNECT POWER LABEL
125	P0637125	READ MANUAL LABEL
126	P0637126	HANDS/OUTLET LABEL
127	P0637127	GLASSES/RESPIRATOR DC LABEL

REF	PART #	DESCRIPTION
128	P0637128	EAR PROTECTION LABEL
129	P0637129	MODEL NUMBER LABEL
130	P0637130	HORSEPOWER LABEL
131	P0637131	CONTROL PANEL LABEL
132	P0637132	REMOTE CONTROL LABEL
133	P0637133	TOUCH-UP PAINT, GRIZZLY GREEN
134	P0637134	TOUCH-UP PAINT, GRIZZLY PUTTY

WARNING

Safety labels help reduce the risk of serious injury caused by machine hazards. If any label comes off or becomes unreadable, the owner of this machine **MUST** replace it in the original location before resuming operations. For replacements, contact (800) 523-4777 or www.grizzly.com.





WARRANTY CARD

Name _____
 Street _____
 City _____ State _____ Zip _____
 Phone # _____ Email _____
 Model # _____ Order # _____ Serial # _____

The following information is given on a voluntary basis. It will be used for marketing purposes to help us develop better products and services. **Of course, all information is strictly confidential.**

1. How did you learn about us?

Advertisement Friend Catalog
 Card Deck Website Other:

2. Which of the following magazines do you subscribe to?

<input type="checkbox"/> Cabinetmaker & FDM	<input type="checkbox"/> Popular Science	<input type="checkbox"/> Wooden Boat
<input type="checkbox"/> Family Handyman	<input type="checkbox"/> Popular Woodworking	<input type="checkbox"/> Woodshop News
<input type="checkbox"/> Hand Loader	<input type="checkbox"/> Precision Shooter	<input type="checkbox"/> Woodsmith
<input type="checkbox"/> Handy	<input type="checkbox"/> Projects in Metal	<input type="checkbox"/> Woodwork
<input type="checkbox"/> Home Shop Machinist	<input type="checkbox"/> RC Modeler	<input type="checkbox"/> Woodworker West
<input type="checkbox"/> Journal of Light Cont.	<input type="checkbox"/> Rifle	<input type="checkbox"/> Woodworker's Journal
<input type="checkbox"/> Live Steam	<input type="checkbox"/> Shop Notes	<input type="checkbox"/> Other:
<input type="checkbox"/> Model Airplane News	<input type="checkbox"/> Shotgun News	
<input type="checkbox"/> Old House Journal	<input type="checkbox"/> Today's Homeowner	
<input type="checkbox"/> Popular Mechanics	<input type="checkbox"/> Wood	

3. What is your annual household income?

\$20,000-\$29,000 \$30,000-\$39,000 \$40,000-\$49,000
 \$50,000-\$59,000 \$60,000-\$69,000 \$70,000+

4. What is your age group?

20-29 30-39 40-49
 50-59 60-69 70+

5. How long have you been a woodworker/metalworker?

0-2 Years 2-8 Years 8-20 Years 20+ Years

6. How many of your machines or tools are Grizzly?

0-2 3-5 6-9 10+

7. Do you think your machine represents a good value? Yes No

8. Would you recommend Grizzly Industrial to a friend? Yes No

9. Would you allow us to use your name as a reference for Grizzly customers in your area?

Note: We never use names more than 3 times. Yes No

10. Comments: _____

CUT ALONG DOTTED LINE

FOLD ALONG DOTTED LINE



Place
Stamp
Here



GRIZZLY INDUSTRIAL, INC.
P.O. BOX 2069
BELLINGHAM, WA 98227-2069



FOLD ALONG DOTTED LINE

Send a Grizzly Catalog to a friend:

Name _____
Street _____
City _____ State _____ Zip _____

TAPE ALONG EDGES--PLEASE DO NOT STAPLE

WARRANTY AND RETURNS

Grizzly Industrial, Inc. warrants every product it sells for a period of **1 year** to the original purchaser from the date of purchase. This warranty does not apply to defects due directly or indirectly to misuse, abuse, negligence, accidents, repairs or alterations or lack of maintenance. This is Grizzly's sole written warranty and any and all warranties that may be implied by law, including any merchantability or fitness, for any particular purpose, are hereby limited to the duration of this written warranty. We do not warrant or represent that the merchandise complies with the provisions of any law or acts unless the manufacturer so warrants. In no event shall Grizzly's liability under this warranty exceed the purchase price paid for the product and any legal actions brought against Grizzly shall be tried in the State of Washington, County of Whatcom.

We shall in no event be liable for death, injuries to persons or property or for incidental, contingent, special, or consequential damages arising from the use of our products.

To take advantage of this warranty, contact us by mail or phone and give us all the details. We will then issue you a "Return Number," which must be clearly posted on the outside as well as the inside of the carton. We will not accept any item back without this number. Proof of purchase must accompany the merchandise.

The manufacturers reserve the right to change specifications at any time because they constantly strive to achieve better quality equipment. We make every effort to ensure that our products meet high quality and durability standards and we hope you never need to use this warranty.

Please feel free to write or call us if you have any questions about the machine or the manual.

Thank you again for your business and continued support. We hope to serve you again soon.

grizzly.com[®]

TOOL WEBSITE

Buy Direct and Save with Grizzly[®] – Trusted, Proven and a Great Value!
~Since 1983~

*Visit Our Website Today For
Current Specials!*

**ORDER
24 HOURS A DAY!
1-800-523-4777**

