

Grizzly **Industrial, Inc.**®

MODEL G0512 **6" X 80" EDGE SANDER** **w/WRAP-AROUND TABLE** **OWNER'S MANUAL** *(For models manufactured since 12/22)*



COPYRIGHT © MAY, 2003 BY GRIZZLY INDUSTRIAL, INC., REVISED MAY, 2024 (CS)
**WARNING: NO PORTION OF THIS MANUAL MAY BE REPRODUCED IN ANY SHAPE
OR FORM WITHOUT THE WRITTEN APPROVAL OF GRIZZLY INDUSTRIAL, INC.**
#528603624 PRINTED IN TAIWAN

V2.05.24

*****Keep for Future Reference*****



WARNING!

This manual provides critical safety instructions on the proper setup, operation, maintenance, and service of this machine/tool. Save this document, refer to it often, and use it to instruct other operators.

Failure to read, understand and follow the instructions in this manual may result in fire or serious personal injury—including amputation, electrocution, or death.

The owner of this machine/tool is solely responsible for its safe use. This responsibility includes but is not limited to proper installation in a safe environment, personnel training and usage authorization, proper inspection and maintenance, manual availability and comprehension, application of safety devices, cutting/sanding/grinding tool integrity, and the usage of personal protective equipment.

The manufacturer will not be held liable for injury or property damage from negligence, improper training, machine modifications or misuse.



WARNING!

Some dust created by power sanding, sawing, grinding, drilling, and other construction activities contains chemicals known to the State of California to cause cancer, birth defects or other reproductive harm. Some examples of these chemicals are:

- **Lead from lead-based paints.**
- **Crystalline silica from bricks, cement and other masonry products.**
- **Arsenic and chromium from chemically-treated lumber.**

Your risk from these exposures varies, depending on how often you do this type of work. To reduce your exposure to these chemicals: Work in a well ventilated area, and work with approved safety equipment, such as those dust masks that are specially designed to filter out microscopic particles.

Table of Contents

INTRODUCTION	2	SECTION 5: ACCESSORIES	31
Contact Info	2	SECTION 6: MAINTENANCE	33
Manual Accuracy	2	Schedule	33
Identification.....	3	Cleaning & Protecting	33
Controls & Components.....	4	Cleaning Sanding Belt	33
Machine Data Sheet	6	Lubrication	34
SECTION 1: SAFETY	8	SECTION 7: SERVICE	35
Safety Instructions for Machinery	8	Troubleshooting	35
Additional Safety for Edge Sanders.....	10	Adjusting Belt Tensioner	37
SECTION 2: POWER SUPPLY	11	Resetting Tension Shaft Spring	38
SECTION 3: SETUP	14	Checking/Adjusting Parallel Belt Tracking ...	39
Needed for Setup.....	14	Platen-to-Roller Adjustments	40
Unpacking	14	SECTION 8: WIRING	44
Inventory	15	Wiring Safety Instructions	44
Cleanup.....	16	Wiring Diagram.....	45
Site Considerations.....	17	SECTION 9: PARTS	46
Assembly	18	Main	46
Power Connection	19	Labels & Cosmetics	48
Test Run.....	20	WARRANTY & RETURNS	49
Installing Table	21		
Dust Collection.....	23		
SECTION 4: OPERATIONS	24		
Operation Overview	24		
Workpiece Inspection.....	25		
Sanding Tips	25		
Choosing Sanding Belts	26		
Installing/Changing Sanding Belts	26		
Pre-Tracking Belt	27		
Checking/Adjusting Belt Tracking	28		
Adjusting Table Height.....	29		
Edge & End Sanding	29		
Contour Sanding.....	30		

INTRODUCTION

Contact Info

We stand behind our machines! If you have questions or need help, contact us with the information below. Before contacting, make sure you get the **serial number** and **manufacture date** from the machine ID label. This will help us help you faster.

Grizzly Technical Support
1815 W. Battlefield
Springfield, MO 65807
Phone: (570) 546-9663
Email: techsupport@grizzly.com

We want your feedback on this manual. What did you like about it? Where could it be improved? Please take a few minutes to give us feedback.

Grizzly Documentation Manager
P.O. Box 2069
Bellingham, WA 98227-2069
Email: manuals@grizzly.com

Manual Accuracy

We are proud to provide a high-quality owner's manual with your new machine!

We made every effort to be exact with the instructions, specifications, drawings, and photographs in this manual. Sometimes we make mistakes, but our policy of continuous improvement also means that **sometimes the machine you receive is slightly different than shown in the manual.**

If you find this to be the case, and the difference between the manual and machine leaves you confused or unsure about something, check our website for an updated version. We post current manuals and manual updates for free on our website at www.grizzly.com.

Alternatively, you can call our Technical Support for help. Before calling, make sure you write down the **manufacture date** and **serial number** from the machine ID label (see below). This information is required for us to provide proper tech support, and it helps us determine if updated documentation is available for your machine.

Grizzly Industrial MODEL GXXXX
MACHINE NAME

SPECIFICATIONS	WARNING!
Motor: _____	To reduce risk of serious injury when using this machine:
Specification: _____	1. Read manual before operation.
Specification: _____	2. Wear safety glasses and respirator.
Specification: _____	3. Make sure safety is correctly adjusted/setup and
Weight: _____	4. power is connected to grounded circuit before starting.
Date: _____	5. Make sure the motor has stopped and disconnect
_____	6. power before adjustments, maintenance, or service.
_____	7. DO NOT expose to rain or dampness.
_____	8. DO NOT modify this machine in any way.
_____	9. _____ended.
_____	10. _____ of drugs or alcohol.
_____	11. Maintain machine carefully to prevent accidents.

Manufactured for Grizzly in Taiwan



Identification

Become familiar with the names and locations of the controls and features shown below to better understand the instructions in this manual.

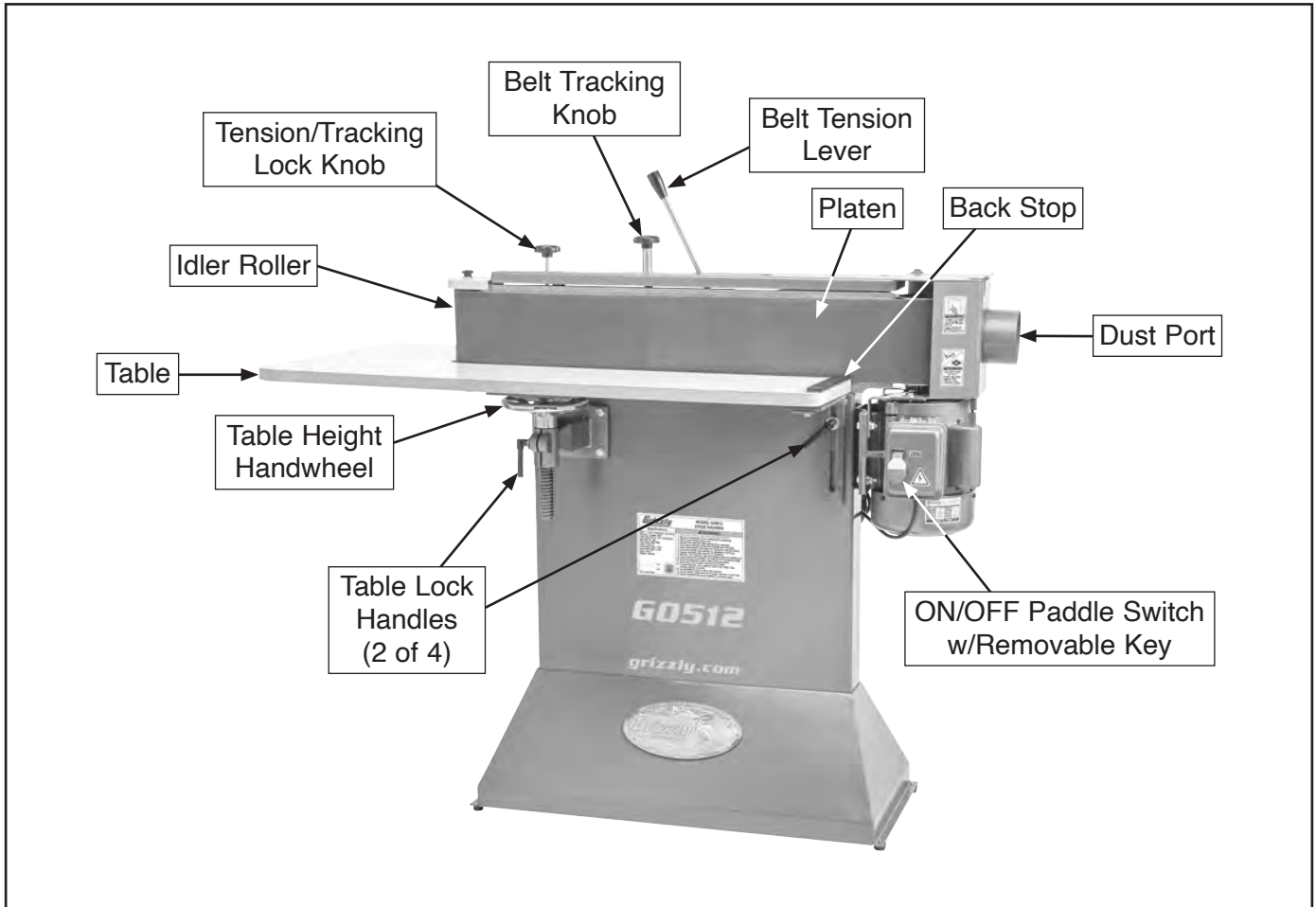

⚠️ WARNING

For Your Own Safety Read Instruction Manual Before Operating Sander

- a) Wear eye protection.
- b) Support workpiece with backstop or worktable.
- c) Maintain $\frac{1}{16}$ " maximum clearance between table and sanding belt.
- d) Avoid kickback by sanding in accordance with directional arrows.



Controls & Components

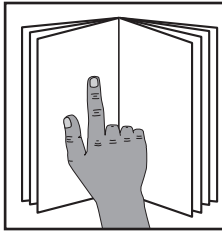

!WARNING

To reduce your risk of serious injury, read this entire manual **BEFORE** using machine.

!WARNING

Like all machinery there is potential danger when operating this machine. Accidents are frequently caused by lack of familiarity or failure to pay attention. Use this machine with respect and caution to decrease the risk of operator injury. If normal safety precautions are overlooked or ignored, serious personal injury may occur.

!CAUTION

No list of safety guidelines can be complete. Every shop environment is different. Always consider safety first, as it applies to your individual working conditions. Use this and other machinery with caution and respect. Failure to do so could result in serious personal injury, damage to equipment, or poor work results.

Refer to the following figures and descriptions to become familiar with the basic controls and components of this machine. Understanding these items and how they work will help you understand the rest of the manual and minimize your risk of injury when operating this machine.

Sanding Surfaces

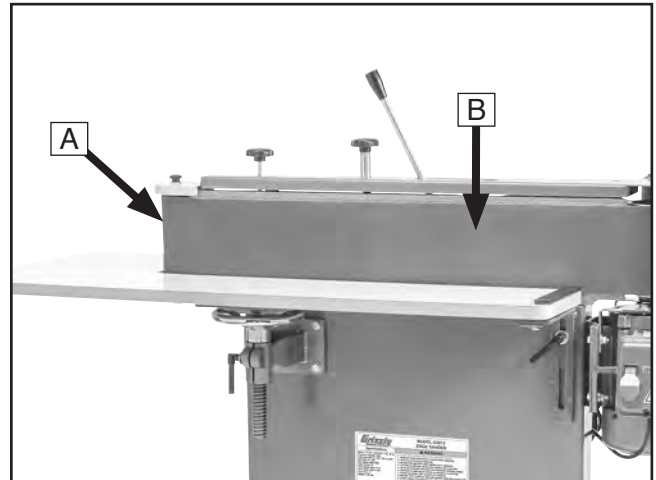

Figure 1. Sanding surfaces.

- A. **Idler Roller:** Provides belt support for curved sanding surface.
- B. **Platen:** Provides belt support for flat sanding surface.

Power Controls

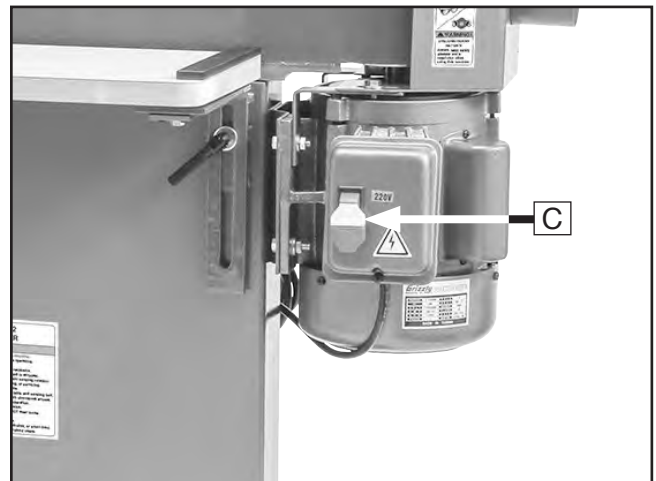

Figure 2. Location of ON/OFF switch.

- C. **ON/OFF Paddle Switch w/Removable Key:** Turns motor **ON** and **OFF**. Remove yellow key to disable switch.



Table Components

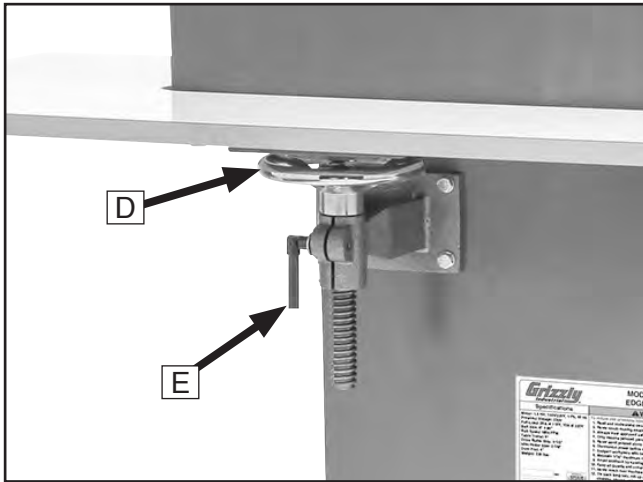

Figure 3. Table height controls.

- D. **Table Height Handwheel:** Adjusts table height.
- E. **Table Lock Handle (1 of 4):** Loosens to adjust table height; tightens to lock table height.

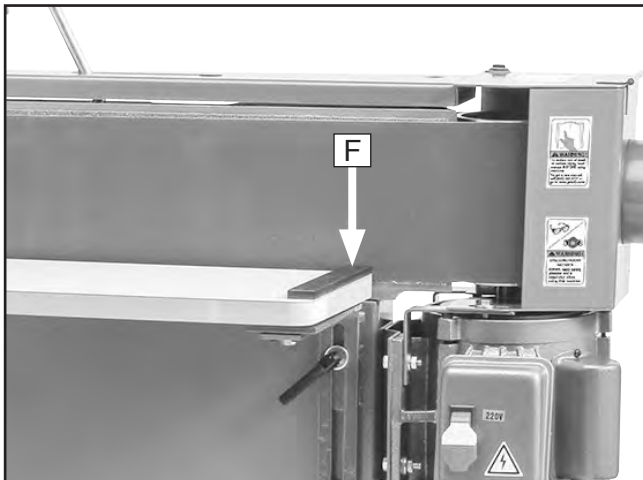

Figure 4. Location of back stop.

- F. **Back Stop:** Supports workpiece so it does not follow belt travel.

Tension & Tracking Controls

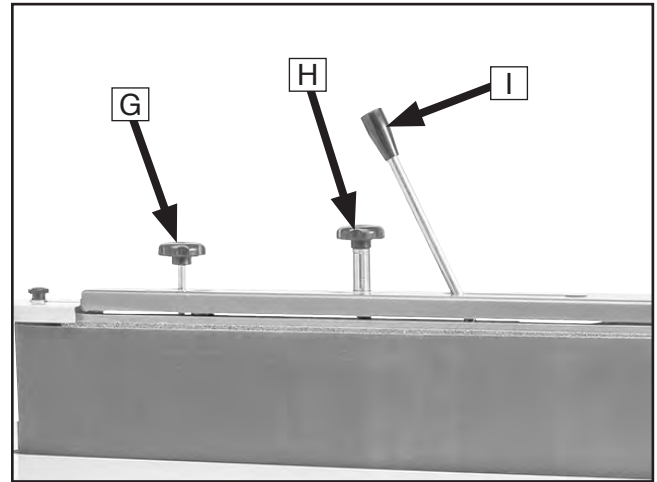

Figure 5. Tension and tracking components.

- G. **Tension/Tracking Lock Knob:** Loosens to allow tension and tracking adjustments; tightens to secure settings.
- H. **Belt Tracking Knob:** Adjusts sanding belt tracking.
- I. **Belt Tension Lever:** Moves away from motor to tension sanding belt; moves toward motor to release sanding belt tension.





MACHINE DATA SHEET

Customer Service #: (570) 546-9663 · To Order Call: (800) 523-4777 · Fax #: (800) 438-5901

MODEL G0512 6" X 80" EDGE SANDER W/ WRAP-AROUND TABLE

Product Dimensions:

Weight..... 235 lbs.
Width (side-to-side) x Depth (front-to-back) x Height..... 52-1/2 x 24 x 48-3/4 in.
Footprint (Length x Width)..... 32 x 14-1/2 in.

Shipping Dimensions:

Carton #1

Type..... Cardboard Box
Content..... Machine
Weight..... 227 lbs.
Length x Width x Height..... 45 x 45 x 20 in.
Must Ship Upright..... Yes

Carton #2

Type..... Cardboard Box
Content..... Table
Weight..... 24 lbs.
Length x Width x Height..... 27 x 46 x 3 in.
Must Ship Upright..... No

Electrical:

Power Requirement..... 110V or 220V, Single-Phase, 60 Hz
Prewired Voltage..... 220V
Full-Load Current Rating..... 20A at 110V, 10A at 220V
Minimum Circuit Size..... 30A at 110V, 15A at 220V
Connection Type..... Cord & Plug
Power Cord Included..... Yes
Power Cord Length..... 72 in.
Power Cord Gauge..... 16 AWG
Plug Included..... No
Recommended Plug Type..... L5-30 for 110V, 6-15 for 220V
Switch Type..... Paddle Safety Switch w/Removable Key

Motors:

Main

Horsepower..... 1.5 HP
Phase..... Single-Phase
Amps..... 20A/10A
Speed..... 1720 RPM
Type..... TEFC Capacitor-Start Induction
Power Transfer..... Direct Drive
Bearings..... Shielded & Permanently Lubricated
Centrifugal Switch/Contacts Type..... External



Main Specifications:

Operation Information

Sanding Belt Speed.....	1800 FPM
Sanding Belt Length.....	80 in.
Sanding Belt Width.....	6 in.

Table Information

Table Length.....	42-1/4 in.
Table Width.....	23-5/8 in.
Table Thickness.....	7/8 in.
Table Travel.....	5 in.
Floor To Table Height.....	33 – 38 in.

Platen Information

Platen Type.....	Graphite Coated
Platen Length.....	31-1/2 in.
Platen Width.....	6-1/4 in.

Construction

Table.....	Composite Wood w/Plastic Laminate
Frame.....	Steel
Base.....	Steel
Drive Roller.....	Aluminum
Idler Roller.....	Rubber
Paint Type/Finish.....	Powder Coated

Other Related Information

Number of Dust Ports.....	1
Dust Port Size.....	4 in.
Belt Release.....	Quick Release
Drive Roller Size.....	4-1/2 in.
Idler Roller Size.....	2-1/8 in.
Mobile Base.....	D2058A, D2246A

Other Specifications:

Country of Origin	Taiwan
Warranty	1 Year
Approximate Assembly & Setup Time	30 Minutes
Serial Number Location	ID Label on Front of Stand
ISO 9001 Factory	Yes

Features:

- Wrap Around Table
- Paddle Switch with Safety Key
- Work Stop
- Quick Belt Release
- Conveniently Located Belt Tracking and Tension Adjustment
- Handwheel Table Height Adjustment
- Powder Coated Finish



SECTION 1: SAFETY

For Your Own Safety, Read Instruction Manual Before Operating This Machine

The purpose of safety symbols is to attract your attention to possible hazardous conditions. This manual uses a series of symbols and signal words intended to convey the level of importance of the safety messages. The progression of symbols is described below. Remember that safety messages by themselves do not eliminate danger and are not a substitute for proper accident prevention measures. Always use common sense and good judgment.



Indicates an imminently hazardous situation which, if not avoided, **WILL** result in death or serious injury.



Indicates a potentially hazardous situation which, if not avoided, **COULD** result in death or serious injury.



Indicates a potentially hazardous situation which, if not avoided, **MAY** result in minor or moderate injury. It may also be used to alert against unsafe practices.

NOTICE

Alerts the user to useful information about proper operation of the machine to avoid machine damage.

Safety Instructions for Machinery

WARNING

OWNER'S MANUAL. Read and understand this owner's manual **BEFORE** using machine.

TRAINED OPERATORS ONLY. Untrained operators have a higher risk of being hurt or killed. Only allow trained/supervised people to use this machine. When machine is not being used, disconnect power, remove switch keys, or lock-out machine to prevent unauthorized use—especially around children. Make your workshop kid proof!

DANGEROUS ENVIRONMENTS. Do not use machinery in areas that are wet, cluttered, or have poor lighting. Operating machinery in these areas greatly increases the risk of accidents and injury.

MENTAL ALERTNESS REQUIRED. Full mental alertness is required for safe operation of machinery. Never operate under the influence of drugs or alcohol, when tired, or when distracted.

ELECTRICAL EQUIPMENT INJURY RISKS.

You can be shocked, burned, or killed by touching live electrical components or improperly grounded machinery. To reduce this risk, only allow qualified service personnel to do electrical installation or repair work, and always disconnect power before accessing or exposing electrical equipment.

DISCONNECT POWER FIRST. Always disconnect machine from power supply **BEFORE** making adjustments, changing tooling, or servicing machine. This prevents an injury risk from unintended startup or contact with live electrical components.

EYE PROTECTION. Always wear ANSI-approved safety glasses or a face shield when operating or observing machinery to reduce the risk of eye injury or blindness from flying particles. Everyday eyeglasses are **NOT** approved safety glasses.



WARNING

WEARING PROPER APPAREL. Do not wear loose clothing, gloves, neckties, or jewelry that can become entangled in moving parts. Always tie back or cover long hair. Wear non-slip footwear to reduce risk of slipping and losing control or accidentally contacting cutting tool or moving parts.

HAZARDOUS DUST. Dust created by machinery operations may cause cancer, birth defects, or long-term respiratory damage. Be aware of dust hazards associated with each workpiece material. Always wear a NIOSH-approved respirator to reduce your risk.

HEARING PROTECTION. Always wear hearing protection when operating or observing loud machinery. Extended exposure to this noise without hearing protection can cause permanent hearing loss.

REMOVE ADJUSTING TOOLS. Tools left on machinery can become dangerous projectiles upon startup. Never leave chuck keys, wrenches, or any other tools on machine. Always verify removal before starting!

USE CORRECT TOOL FOR THE JOB. Only use this tool for its intended purpose—do not force it or an attachment to do a job for which it was not designed. Never make unapproved modifications—modifying tool or using it differently than intended may result in malfunction or mechanical failure that can lead to personal injury or death!

AWKWARD POSITIONS. Keep proper footing and balance at all times when operating machine. Do not overreach! Avoid awkward hand positions that make workpiece control difficult or increase the risk of accidental injury.

CHILDREN & BYSTANDERS. Keep children and bystanders at a safe distance from the work area. Stop using machine if they become a distraction.

GUARDS & COVERS. Guards and covers reduce accidental contact with moving parts or flying debris. Make sure they are properly installed, undamaged, and working correctly **BEFORE** operating machine.

FORCING MACHINERY. Do not force machine. It will do the job safer and better at the rate for which it was designed.

NEVER STAND ON MACHINE. Serious injury may occur if machine is tipped or if the cutting tool is unintentionally contacted.

STABLE MACHINE. Unexpected movement during operation greatly increases risk of injury or loss of control. Before starting, verify machine is stable and mobile base (if used) is locked.

USE RECOMMENDED ACCESSORIES. Consult this owner's manual or the manufacturer for recommended accessories. Using improper accessories will increase the risk of serious injury.

UNATTENDED OPERATION. To reduce the risk of accidental injury, turn machine **OFF** and ensure all moving parts completely stop before walking away. Never leave machine running while unattended.

MAINTAIN WITH CARE. Follow all maintenance instructions and lubrication schedules to keep machine in good working condition. A machine that is improperly maintained could malfunction, leading to serious personal injury or death.

DAMAGED PARTS. Regularly inspect machine for damaged, loose, or mis-adjusted parts—or any condition that could affect safe operation. Immediately repair/replace **BEFORE** operating machine. For your own safety, **DO NOT** operate machine with damaged parts!

MAINTAIN POWER CORDS. When disconnecting cord-connected machines from power, grab and pull the plug—**NOT** the cord. Pulling the cord may damage the wires inside. Do not handle cord/plug with wet hands. Avoid cord damage by keeping it away from heated surfaces, high traffic areas, harsh chemicals, and wet/damp locations.

EXPERIENCING DIFFICULTIES. If at any time you experience difficulties performing the intended operation, stop using the machine! Contact our Technical Support at (570) 546-9663.



Additional Safety for Edge Sanders

WARNING

Serious injury or death can occur if fingers, clothing, jewelry, or hair get entangled in moving components. Impact injuries can occur from kickback if workpiece is improperly fed into moving sandpaper. Serious pinch injuries can occur from touching in-running nip point between table and sanding surface. Long-term respiratory damage can occur from using sander without proper use of a respirator. To reduce the risk of these hazards, operator and bystanders **MUST** completely heed the hazards and warnings below.

AVOIDING ENTANGLEMENT. Becoming entangled in moving parts of this machine can cause pinching and crushing injuries. To avoid these hazards, **DO NOT** wear loose clothing, gloves, or jewelry, and tie back long hair. Keep all guards in place and secure.

IN-RUNNING NIP POINTS. The gap between moving sandpaper and fixed table/support creates a pinch point for fingers or workpieces; the larger this gap is, the greater risk of fingers or workpieces getting caught in it. Minimize this risk by adjusting table no more than $\frac{1}{16}$ " away from sandpaper.

SANDPAPER DIRECTION. Feeding workpiece incorrectly can cause it to be thrown from machine, striking operator or bystanders, or causing your hands to slip into the moving sandpaper. To reduce these risks, only sand against direction of sandpaper travel, ensure workpiece is properly supported, and avoid introducing sharp edges into moving sandpaper on leading side of workpiece.

WORKPIECE SUPPORT & HAND PLACEMENT. Rotating sandpaper can remove a large amount of skin quickly, and kickback can occur with violent force if workpiece is not properly supported during operation. Always sand with workpiece firmly against table or another support device. Never touch moving sandpaper on purpose.

WORKPIECE INTEGRITY. Only sand solid workpieces that can withstand power sanding forces. Make sure shape of workpiece is properly supported on table; avoid sanding workpieces without flat bottom surfaces unless some type of jig is used to maintain support and control when sanding force is applied.

FEEDING WORKPIECE. Forcefully jamming workpiece into sanding surface could cause workpiece to be aggressively grabbed and pull your hands into sanding surface. Firmly grasp workpiece in both hands and ease it into sandpaper using light pressure.

SMALL WORKPIECES. Small workpieces are difficult to control and require close support near sanding surface. Always use a jig or other holding device when sanding small workpieces, and keep hands and fingers at least 2" away from sanding surface.

WORKPIECE INSPECTION. Nails, staples, knots, or other imperfections in workpiece can be dislodged and thrown from sander at high rate of speed into operator or bystanders, or cause damage to sandpaper or sander. Never try to sand stock that has embedded foreign objects or questionable imperfections.

SANDPAPER CONDITION. Worn or damaged sandpaper not only produces poor sanding results, but could fly apart, aggressively grab workpiece, and throw debris at the operator. Always inspect sandpaper before operation and replace if worn or damaged.

SANDING DUST & DUST COLLECTION. Sanding creates large amounts of dust and flying particles that can lead to eye injury or respiratory illness. Reduce risk by wearing approved eye and respiratory protection when using sander. Never operate without adequate dust-collection system in place and running. Proper dust collection reduces dust in work area, decreasing risk of long-term respiratory damage, but it is not a substitute for using a respirator.



SECTION 2: POWER SUPPLY

Availability

Before installing the machine, consider the availability and proximity of the required power supply circuit. If an existing circuit does not meet the requirements for this machine, a new circuit must be installed. To minimize the risk of electrocution, fire, or equipment damage, installation work and electrical wiring must be done by an electrician or qualified service personnel in accordance with all applicable codes and standards.

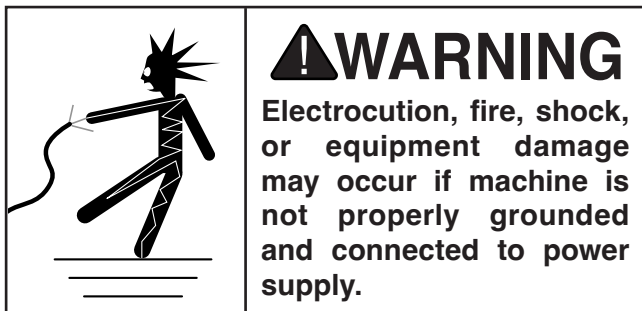

Full-Load Current Rating

The full-load current rating is the amperage a machine draws at 100% of the rated output power. On machines with multiple motors, this is the amperage drawn by the largest motor or sum of all motors and electrical devices that might operate at one time during normal operations.

Full-Load Current Rating at 220V 10 Amps

Full-Load Current Rating at 110V 20 Amps

The full-load current is not the maximum amount of amps that the machine will draw. If the machine is overloaded, it will draw additional amps beyond the full-load rating.

If the machine is overloaded for a sufficient length of time, damage, overheating, or fire may result—especially if connected to an undersized circuit. To reduce the risk of these hazards, avoid overloading the machine during operation and make sure it is connected to a power supply circuit that meets the specified circuit requirements.

Circuit Information

A power supply circuit includes all electrical equipment between the breaker box or fuse panel in the building and the machine. The power supply circuit used for this machine must be sized to safely handle the full-load current drawn from the machine for an extended period of time. (If this machine is connected to a circuit protected by fuses, use a time delay fuse marked D.)



Note: *Circuit requirements in this manual apply to a dedicated circuit—where only one machine will be running on the circuit at a time. If machine will be connected to a shared circuit where multiple machines may be running at the same time, consult an electrician or qualified service personnel to ensure circuit is properly sized for safe operation.*

Circuit Requirements for 220V

This machine is prewired to operate on a power supply circuit that has a verified ground and meets the following requirements:

Nominal Voltage 208V, 220V, 230V, 240V
Cycle 60 Hz
Phase Single-Phase
Power Supply Circuit 15 Amps
Plug/Receptacle NEMA 6-15

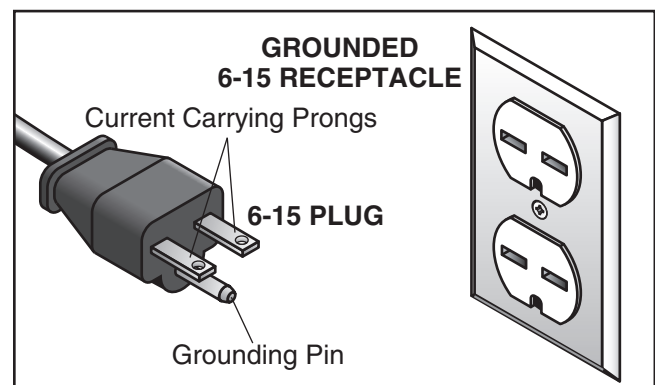

Figure 6. NEMA 6-15 plug and receptacle.



Circuit Requirements for 110V

This machine can be converted to operate on a power supply circuit that has a verified ground and meets the requirements listed below. (Refer to **Voltage Conversion** instructions for details.)

Nominal Voltage 110V, 115V, 120V
Cycle 60 Hz
Phase Single-Phase
Power Supply Circuit 30 Amps
Plug/Receptacle NEMA L5-30

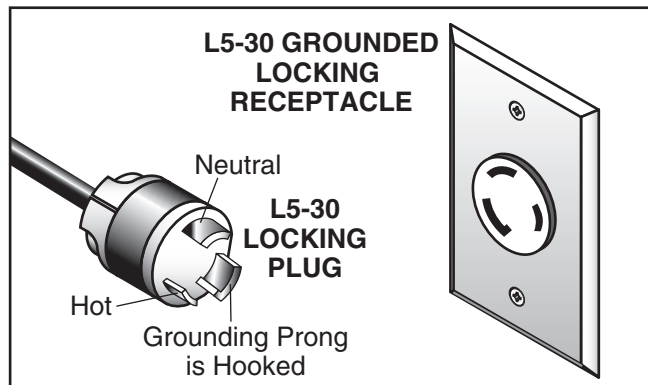

Figure 7. Typical L5-30 plug and receptacle.

Grounding Requirements

This machine **MUST** be grounded. In the event of certain malfunctions or breakdowns, grounding reduces the risk of electric shock by providing a path of least resistance for electric current.

This machine is equipped with a power cord that has an equipment-grounding wire and a grounding plug. Only insert plug into a matching receptacle (outlet) that is properly installed and grounded in accordance with all local codes and ordinances. **DO NOT** modify the provided plug!

Improper connection of the equipment-grounding wire can result in a risk of electric shock. The wire with green insulation (with or without yellow stripes) is the equipment-grounding wire. If repair or replacement of the power cord or plug is necessary, do not connect the equipment-grounding wire to a live (current carrying) terminal.

Check with a qualified electrician or service personnel if you do not understand these grounding requirements, or if you are in doubt about whether the tool is properly grounded. If you ever notice that a cord or plug is damaged or worn, disconnect it from power, and immediately replace it with a new one.

⚠ WARNING

Serious injury could occur if you connect machine to power before completing setup process. **DO NOT** connect to power until instructed later in this manual.

⚠ CAUTION

No adapter should be used with plug. If plug does not fit available receptacle, or if machine must be reconnected for use on a different type of circuit, reconnection must be performed by an electrician or qualified service personnel, and it must comply with all local codes and ordinances.

Extension Cords

We do not recommend using an extension cord with this machine. If you must use an extension cord, only use it if absolutely necessary and only on a temporary basis.

Extension cords cause voltage drop, which can damage electrical components and shorten motor life. Voltage drop increases as the extension cord size gets longer and the gauge size gets smaller (higher gauge numbers indicate smaller sizes).

Any extension cord used with this machine must be in good condition and contain a ground wire and matching plug/receptacle. Additionally, it must meet the following size requirements:

220V Minimum Gauge Size 18 AWG
110V Minimum Gauge Size 10 AWG
Maximum Length (Shorter is Better) 50 ft.



Voltage Conversion

The voltage conversion MUST be performed by a qualified electrician.

To perform the voltage conversion, rewire the motor and install the correct plug. A wiring diagram is provided on **Page 45** for your reference.

If the diagram included on the motor conflicts with the one in this manual, the motor may have changed since the manual was printed. Use the diagram provided on the motor.

Items Needed	Qty
Phillips Head Screwdriver #2	1
Wire Cutters/Stripper.....	1
Electrical Tape.....	As Needed
NEMA L5-30 Plug	1

To convert machine to 110V operation:

1. DISCONNECT MACHINE FROM POWER!
2. Remove screw shown in **Figure 8** to remove motor junction box cover.

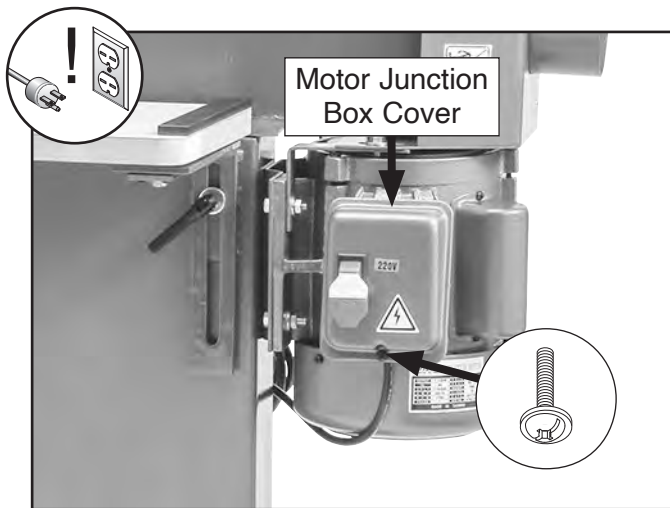

Figure 8. Location of motor junction box cover and screw.

3. Loosen (3) wire nuts indicated in **Figure 9**.

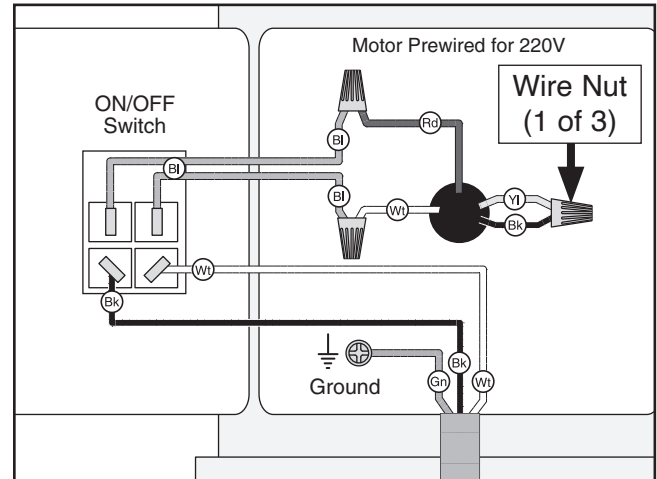

Figure 9. Motor prewired for 220V.

4. Use wire nuts to connect wires as indicated in **Figure 10**. Twist wire nuts onto their respective wires and wrap them with electrical tape so they will not come loose during operation.

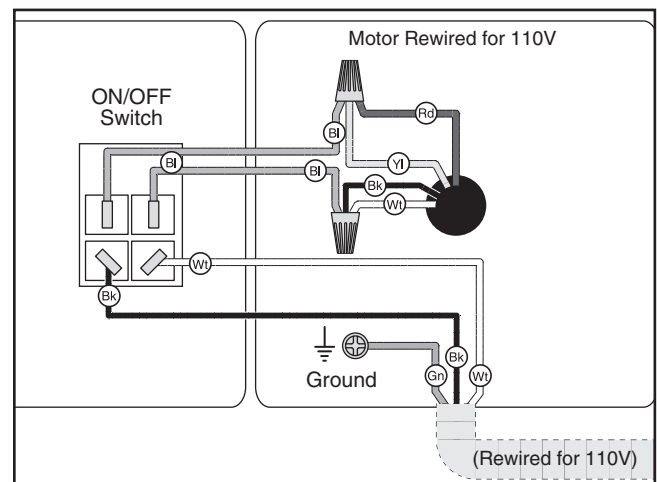
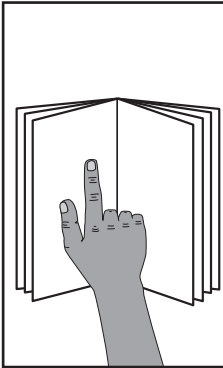

Figure 10. Motor rewired for 110V.

5. Install motor junction box cover with screw removed in **Step 2**.
6. Install L5-30 plug on power cord, according to plug manufacturer's instructions.
 - If plug manufacturer's instructions are not available, NEMA standard L5-30 plug wiring provided on **Page 45**.



SECTION 3: SETUP



⚠️ WARNING

This machine presents serious injury hazards to untrained users. Read through this entire manual to become familiar with the controls and operations before starting the machine!

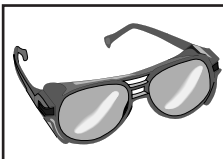

⚠️ WARNING

Wear safety glasses during the entire setup process!



⚠️ WARNING

HEAVY LIFT!

Straining or crushing injury may occur from improperly lifting machine or some of its parts. To reduce this risk, get help from other people and use a forklift (or other lifting equipment) rated for weight of this machine.

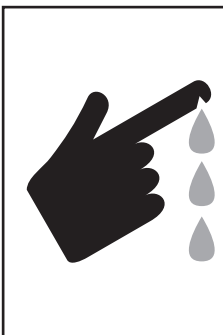

⚠️ CAUTION

Some metal parts may have sharp edges on them after they are formed. Please examine edges of all metal parts before handling them. Failure to do so could result in injury.

Needed for Setup

The following items are needed, but not included, for the setup/assembly of this machine.

Description	Qty
• Disposable Rags	As Needed
• Cleaner/Degreaser	As Needed
• Safety Glasses (for each person).....	1 Pr.
• Disposable Gloves	As Needed
• Another Person	1
• Phillips Head Screwdriver #2	1
• Wrench 12mm	1
• Wrench or Socket 14mm	1
• NEMA 6-15 Plug (for 220V Operation)	1
• Protective Gloves	1 Pr.
• Hex Wrench 1.5mm or 1/16"	1
• Clamps	4
• Level 12"	1
• Square	1
• Power Drill	1
• Drill Bit 1/8"	1
• Dust Hose 4"	1
• Hose Clamps 4"	2
• Dust Collection System	1

Unpacking

This machine was carefully packaged for safe transport. When unpacking, separate all enclosed items from packaging materials and inspect them for shipping damage. ***If items are damaged, please call us immediately at (570) 546-9663.***

IMPORTANT: Save all packaging materials until you are completely satisfied with the machine and have resolved any issues between Grizzly or the shipping agent. ***You MUST have the original packaging to file a freight claim. It is also extremely helpful if you need to return your machine later.***



Inventory

The following is a list of items shipped with your machine. Before beginning setup, lay these items out and inventory them.

If any non-proprietary parts are missing (e.g. a nut or a washer), we will gladly replace them; or for the sake of expediency, replacements can be obtained at your local hardware store.

NOTICE

If you cannot find an item on this list, carefully check around/inside the machine and packaging materials. Often, these items get lost in packaging materials while unpacking or they are pre-installed at the factory.

Loose Inventory (Figure 11)	Qty
A. Table.....	1
B. Idler L-Bracket.....	1
C. Motor L-Bracket.....	1
D. Adjustment L-Bracket.....	1
E. Sanding Belt 6" x 80".....	1
F. Leadscrew Bracket Assembly.....	1
G. Back Stop.....	1
H. Dust Port.....	1
I. Roller Guard.....	1

Fasteners (Figure 12)	Qty
J. Machine Feet.....	4
K. Table Lock Handles.....	3
L. Tap Screws #8 x 3/4".....	19
M. Phillips Head Screws 10-24 x 5/8".....	4
N. Flat Washers 3/8".....	6

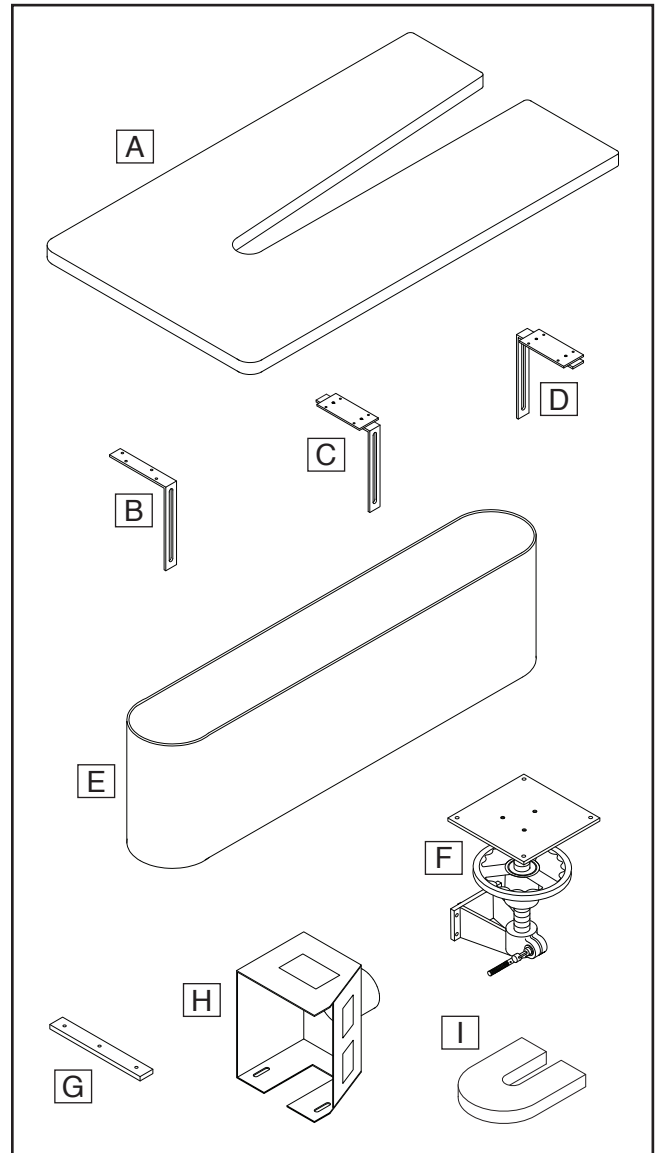

Figure 11. Loose inventory.

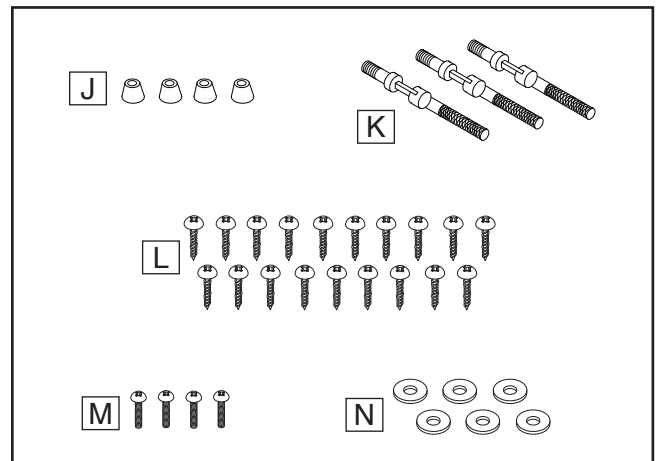

Figure 12. Fasteners.



Cleanup

The unpainted surfaces of your machine are coated with a heavy-duty rust preventative that prevents corrosion during shipment and storage. This rust preventative works extremely well, but it will take a little time to clean.

Be patient and do a thorough job cleaning your machine. The time you spend doing this now will give you a better appreciation for the proper care of your machine's unpainted surfaces.

There are many ways to remove this rust preventative, but the following steps work well in a wide variety of situations. Always follow the manufacturer's instructions with any cleaning product you use and make sure you work in a well-ventilated area to minimize exposure to toxic fumes.

Before cleaning, gather the following:

- Disposable rags
- Cleaner/degreaser (WD-40 works well)
- Safety glasses & disposable gloves
- Plastic paint scraper (optional)

Basic steps for removing rust preventative:

1. Put on safety glasses.
2. Coat the rust preventative with a liberal amount of cleaner/degreaser, then let it soak for 5–10 minutes.
3. Wipe off the surfaces. If your cleaner/degreaser is effective, the rust preventative will wipe off easily. If you have a plastic paint scraper, scrape off as much as you can first, then wipe off the rest with the rag.
4. Repeat **Steps 2–3** as necessary until clean, then coat all unpainted surfaces with a quality metal protectant to prevent rust.

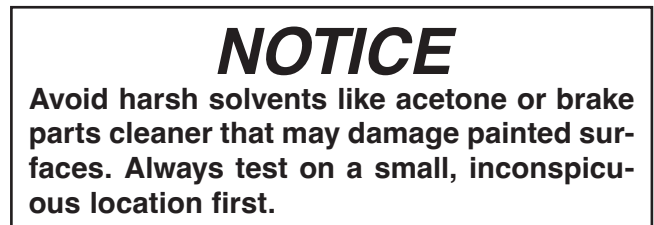
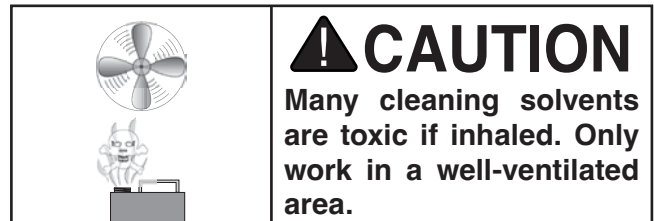
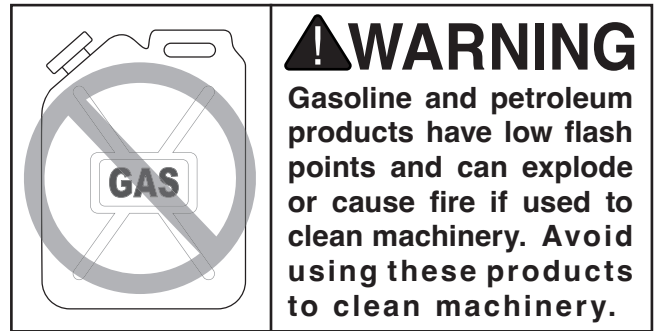

T23692—Orange Power Degreaser

A great product for removing the waxy shipping grease from the *non-painted* parts of the machine during clean up.



Figure 13. T23692 Orange Power Degreaser.



Site Considerations

Weight Load

Refer to the **Machine Data Sheet** for the weight of your machine. Make sure that the surface upon which the machine is placed will bear the weight of the machine, additional equipment that may be installed on the machine, and the heaviest workpiece that will be used. Additionally, consider the weight of the operator and any dynamic loading that may occur when operating the machine.

Space Allocation

Consider the largest size of workpiece that will be processed through this machine and provide enough space around the machine for adequate operator material handling or the installation of auxiliary equipment. With permanent installations, leave enough space around the machine to open or remove doors/covers as required by the maintenance and service described in this manual. **See below for required space allocation.**

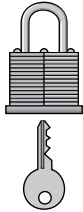
	<p>CAUTION</p> <p>Children or untrained people may be seriously injured by this machine. Only install in an access restricted location.</p>
-------------------------------------------------------------------------------------	----------------------------------------------------------------------------------------------------------------------------------------------------

Physical Environment

The physical environment where the machine is operated is important for safe operation and longevity of machine components. For best results, operate this machine in a dry environment that is free from excessive moisture, hazardous chemicals, airborne abrasives, or extreme conditions. Extreme conditions for this type of machinery are generally those where the ambient temperature range exceeds 41°–104°F; the relative humidity range exceeds 20%–95% (non-condensing); or the environment is subject to vibration, shocks, or bumps.

Electrical Installation

Place this machine near an existing power source. Make sure all power cords are protected from traffic, material handling, moisture, chemicals, or other hazards. Make sure to leave enough space around machine to disconnect power supply or apply a lockout/tagout device, if required.

Lighting

Lighting around the machine must be adequate enough that operations can be performed safely. Shadows, glare, or strobe effects that may distract or impede the operator must be eliminated.

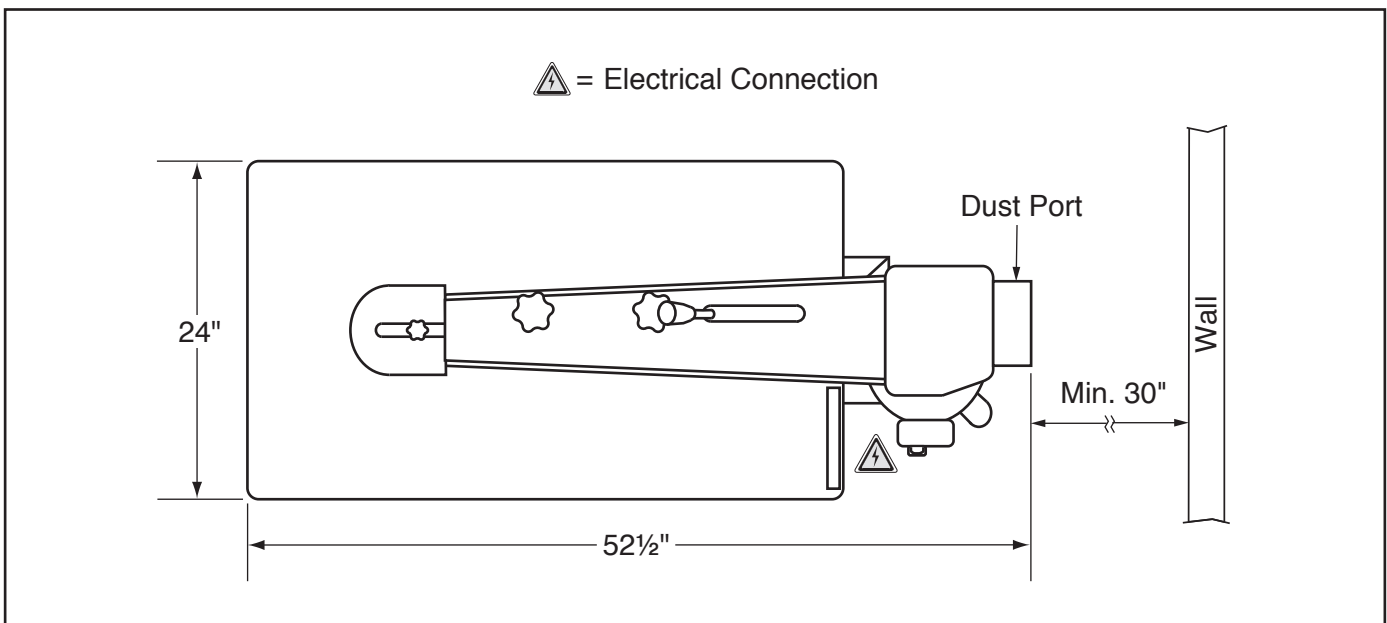
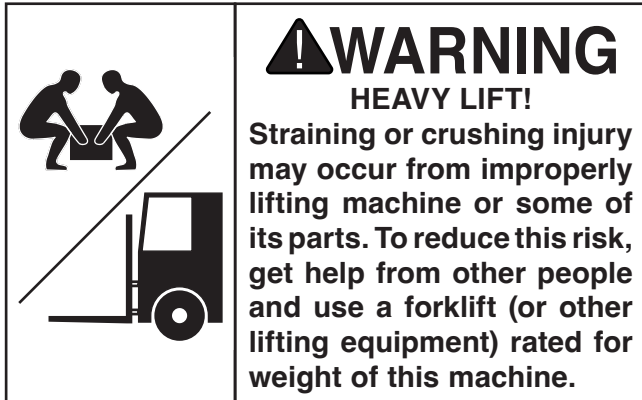

Figure 14. Minimum working clearances.



Assembly

The machine must be fully assembled before it can be operated. Before beginning the assembly process, refer to **Needed for Setup** and gather all listed items. To ensure the assembly process goes smoothly, first clean any parts that are covered or coated in heavy-duty rust preventative (if applicable).



To assemble machine:

1. With help of an assistant, carefully lay machine on its side.
2. Install (4) machine feet on bottom of base with (4) 10-24 x 5/8" Phillips head screws (see **Figure 15**), then stand machine upright.

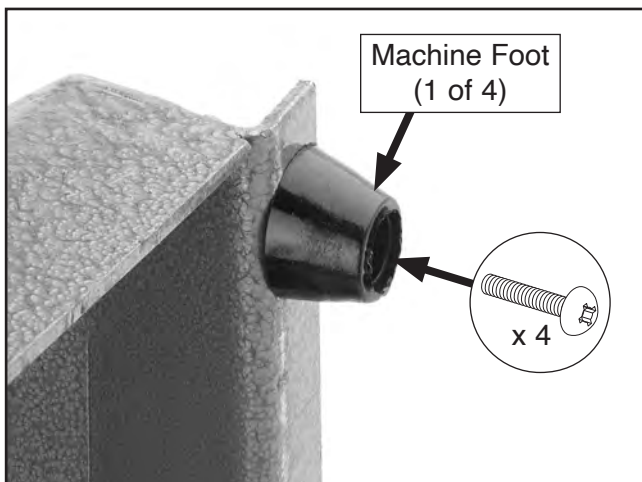

Figure 15. Machine foot installed on base.

3. Loosen tension/tracking lock knob, then move belt tension lever toward motor to release position (see **Figure 16**).

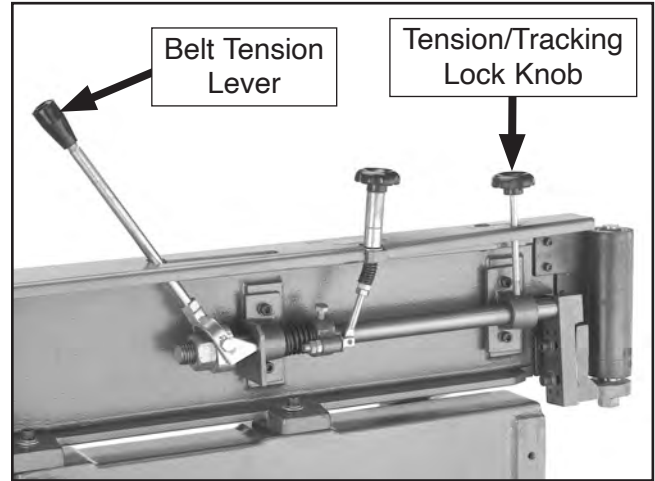

Figure 16. Location of tension/tracking lock knob and tension lever in release position.

4. Making sure arrows on inside of belt point in counterclockwise direction, place sanding belt over both rollers, as shown in **Figure 17**.

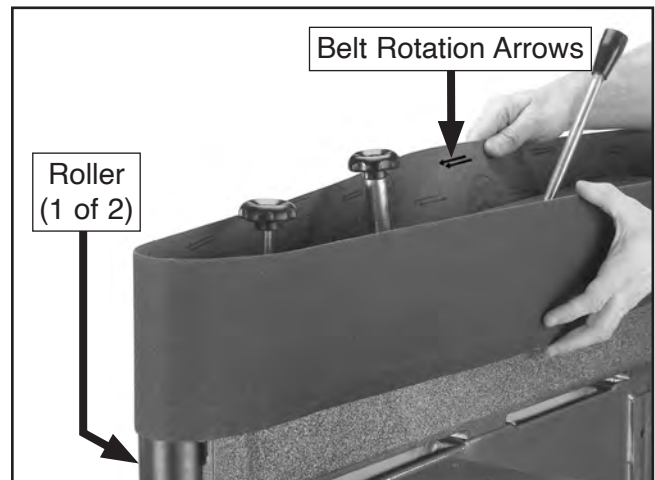

Figure 17. Installing sanding belt on rollers.

5. Move belt tension lever away from motor to tension belt.
6. Tighten tension/tracking lock knob.



- Attach dust port to machine with (2) pre-installed hex bolts and washers shown in **Figure 18**. Finger-tighten for now.

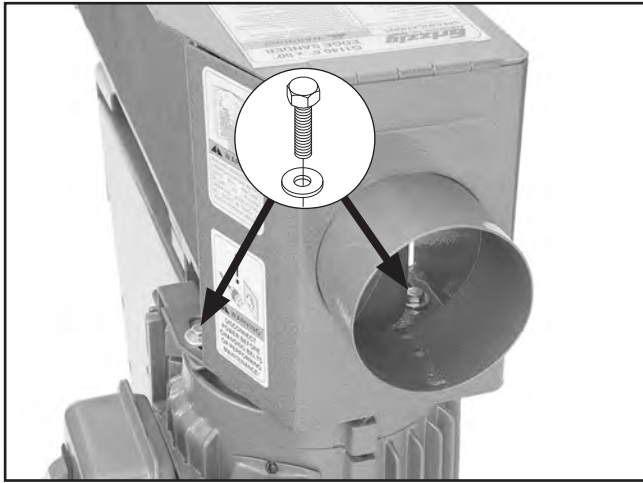

Figure 18. Example of dust port installed.

- Position dust port approximately $\frac{1}{2}$ " away from drive roller and fully tighten bolts from **Step 7**.
- Place roller guard on top of idler roller and secure it in place with pre-installed knob bolt and washer shown in **Figure 19**.

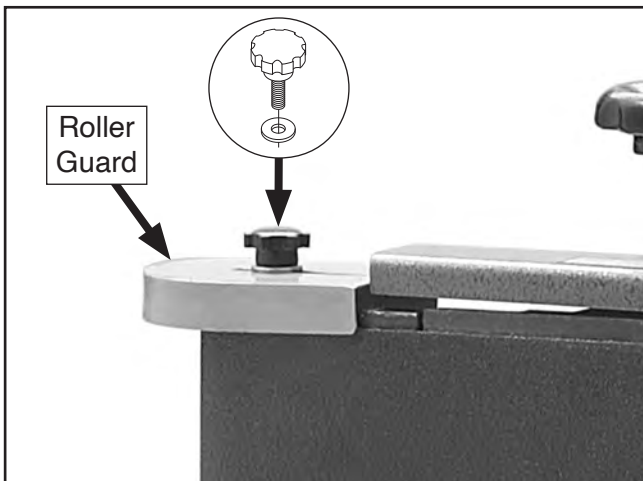

Figure 19. Roller guard secured to top of idler roller.

- Unlatch and open dust port cover shown in **Figure 20**.

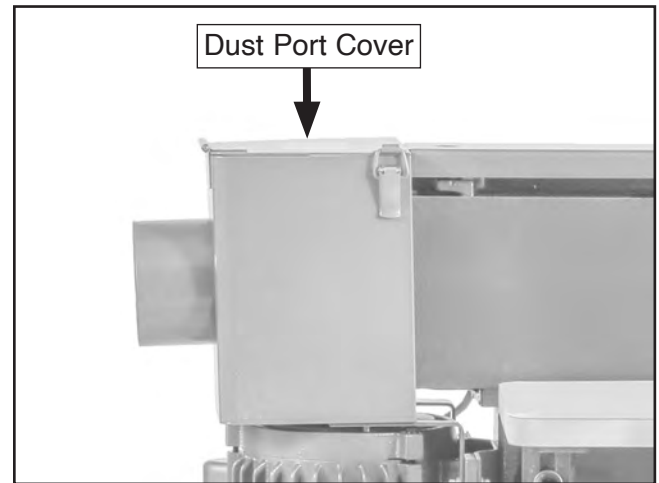

Figure 20. Location of dust port cover.

Note: All other assembly steps must take place after **Test Run** to ensure table is installed correctly in relation to idler roller.

Power Connection

Before the machine can be connected to the power source, an electrical circuit and connection device must be prepared per the **POWER SUPPLY** section in this manual, and all previous setup instructions in this manual must be complete to ensure that the machine has been assembled and installed properly.

Always make sure the ON/OFF switch on the machine is turned OFF before connecting power.

NOTICE

The Model G0512 is prewired for 220V. If you plan to operate the machine at 110V, the motor must be rewired and an L5-30 plug must be installed. Use instructions on Page 13 instead of the ones below.

220V Power Connection

To connect plug to power cord for 220V operation, install 6-15 plug on end of power cord per plug manufacturer's instructions. If no instructions were included, use wiring diagram on **Page 45**.



Test Run

Once assembly is complete, test run the machine to ensure it is properly connected to power and safety components are functioning correctly.

If you find an unusual problem during the test run, immediately stop the machine, disconnect it from power, and fix the problem BEFORE operating the machine again. The **Troubleshooting** table in the **SERVICE** section of this manual can help.

The Test Run consists of verifying the following: 1) The belt tracks properly and will not come off the rollers during initial startup, 2) the motor powers up and runs correctly, and 3) the switch disabling key disables the switch properly.

!WARNING

Serious injury or death can result from using this machine BEFORE understanding its controls and related safety information. DO NOT operate, or allow others to operate, machine until the information is understood.

!WARNING

DO NOT start machine until all preceding setup instructions have been performed. Operating an improperly set up machine may result in malfunction or unexpected results that can lead to serious injury, death, or machine/property damage.

To test run machine:

1. Clear all setup tools away from machine.

!CAUTION

Fingers and other body parts can be quickly injured if they touch moving sanding surfaces. To reduce this risk, wear gloves while manually pushing belt.

2. Follow **Steps 3–5** as described in **Pre-Tracking Belt** on **Page 27** to pre-track sanding belt.

3. Connect machine to power supply.
4. Use ON/OFF switch to start and immediately stop machine, while watching how belt tracks on rollers. Belt "tracking" refers to belt position on rollers when belt rotates. When tracking properly, top of belt stays aligned with top of drive roller (see **Figure 39** on **Page 28**).
 - If top of belt *does* stay aligned with top of drive roller, proceed to **Step 5**.
 - If top of belt *does not* stay aligned with top of drive roller, you must adjust belt tracking before proceeding to next step so belt is not damaged. Refer to **Checking/Adjusting Belt Tracking** on **Page 28** and follow **Steps 3–7** before continuing.
5. Start machine and allow it to run while ensuring belt tracks properly. Motor should run smoothly and without unusual problems or noises.
6. Turn machine **OFF**.
7. Remove switch disabling key, as shown in **Figure 21**.

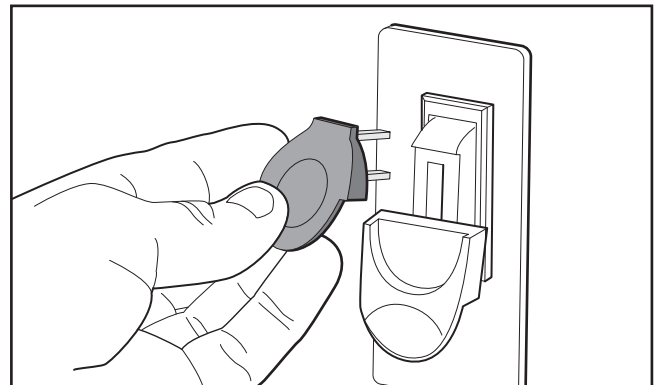

Figure 21. Removing switch disabling key.

8. Try to start machine with ON/OFF switch. Machine should not start.
 - If machine *does not* start, switch disabling feature is working correctly.
 - If machine *does start*, immediately stop machine. Switch disabling feature is not working correctly. This safety feature must work properly before proceeding with operations. Call Tech Support for help.



Installing Table

Before installing the table, the sanding belt must be tracking correctly to ensure that the idler roller is close to the position that it will be in during operation. Do not perform the following steps until after the **Test Run** is complete.

To install table:

1. DISCONNECT MACHINE FROM POWER!
2. Attach leadscrew bracket assembly to stand with (4) pre-installed hex bolts and washers shown in **Figure 22**.

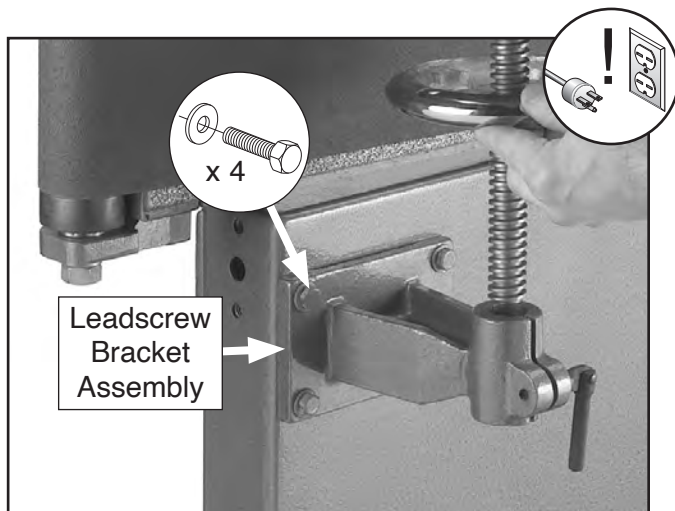

Figure 22. Leadscrew bracket assembly attached to stand.

3. Identify which L-bracket is which before continuing (see **Figure 23**).

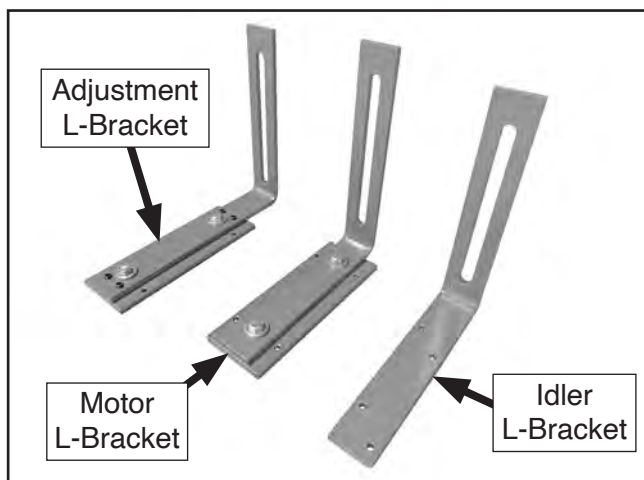

Figure 23. L-bracket identification.

4. Attach motor L-bracket to rear of stand on side closest to motor with table lock handle and (2) $\frac{3}{8}$ " flat washers, as shown in **Figure 24**.

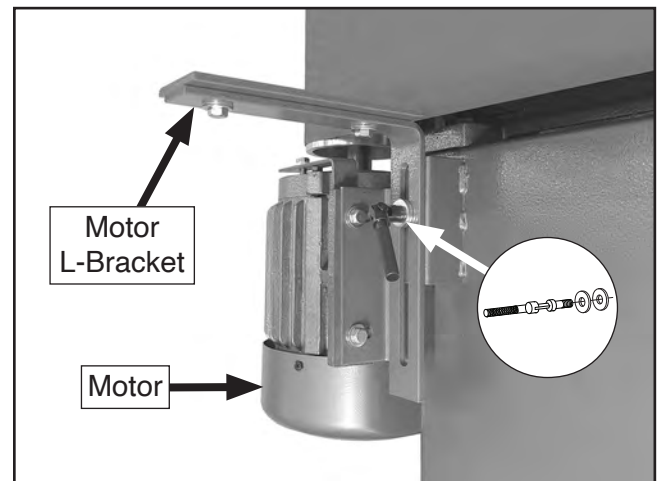

Figure 24. Motor L-bracket installed.

5. Repeat **Step 4** with idler L-bracket at rear left of machine, as shown in **Figure 25**.

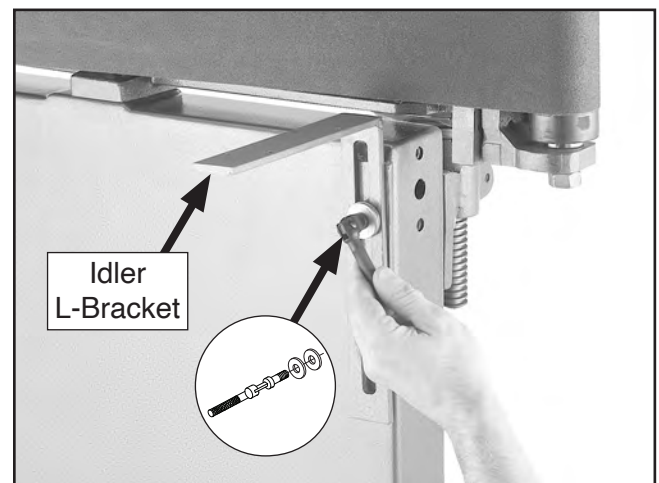

Figure 25. Idler L-bracket installed.

6. Repeat **Step 4** with adjustment L-bracket at remaining location on front right of machine.
7. Loosen all (4) table lock handles, use table height handwheel to lower leadscrew table bracket all the way down (see **Figure 26**), then adjust L-brackets as far down as they will go.



- Use table height handwheel to raise table bracket one full turn, then tighten table lock handle (see **Figure 26**).

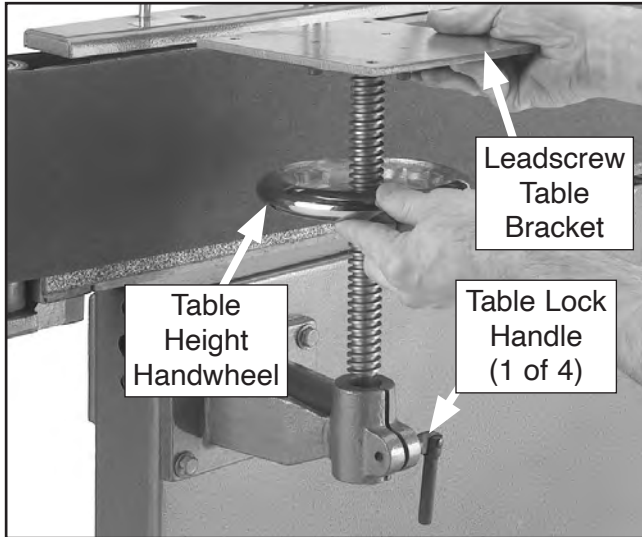

Figure 26. Lowering leadscrew table bracket.

- Position table over leadscrew table bracket and L-brackets.
- Clamp table to leadscrew table bracket, and have assistant hold table in place.
- Raise each L-bracket until it just touches bottom of table, then tighten lock handles.
- Place level on table to check table is level side to side and front to back. Adjust height of L-brackets as necessary.
- Remove clamp from leadscrew table bracket.
- Place square against front center of table and platen (see **Figure 27**).

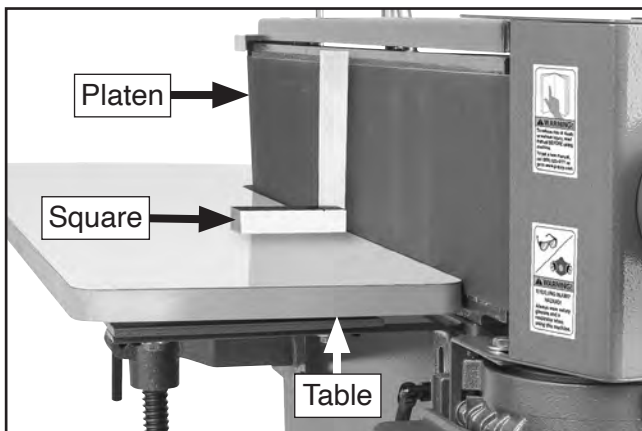

Figure 27. Square against table and platen.

- Adjust set screws on adjustment L-bracket until table is square to platen (see **Figure 28**).

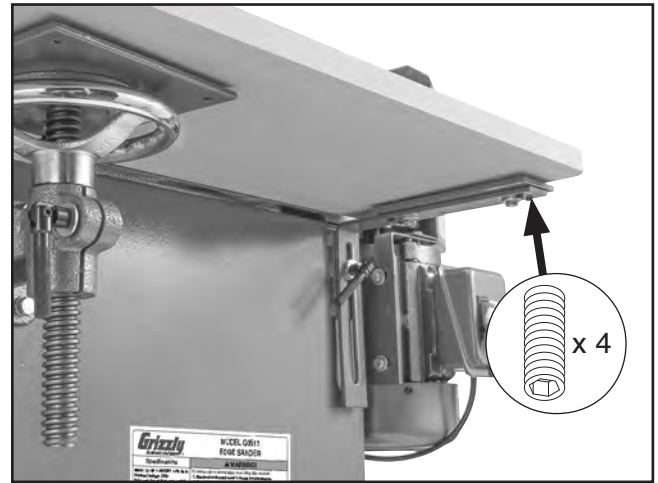

Figure 28. Location of adjustment L-bracket set screws.

- Re-check that front of table is still level.
 - If front of table *is* level, proceed to **Step 17**.
 - If front of table *is not* level, loosen adjustment L-bracket lock handle, adjust bracket until table is level, then tighten lock handle.
- Use 1.5mm or 1/16" hex wrench as gauge to position table evenly away from platen and idler roller, as shown in **Figure 29**, at locations shown in **Figure 30**.

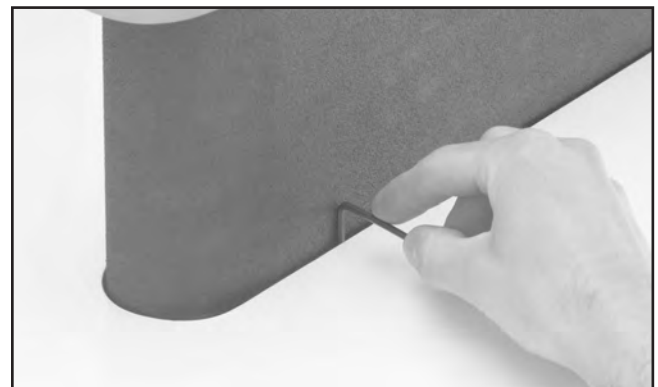

Figure 29. Using hex wrench as gauge to position table.



Dust Collection

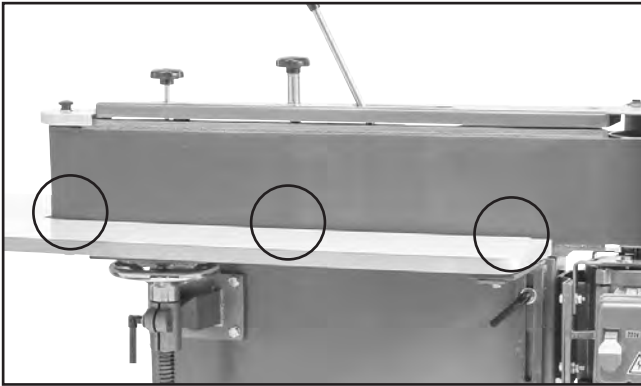

Figure 30. Locations to gauge table spacing.

18. Clamp table to L-brackets and table leadscrew bracket, then secure table brackets to table with (16) #8 x $\frac{3}{4}$ " tap screws.
19. Align back stop with edge of table (see **Figure 31**), then use square to square back stop to platen.
20. Mark (3) back stop mounting holes, remove back stop, then drill $\frac{1}{8}$ " diameter pilot holes in table (see **Figure 31**).

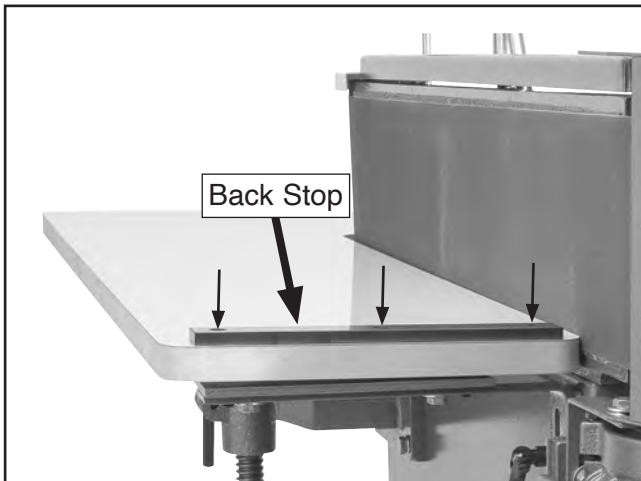

Figure 31. Back stop mounting hole locations.

21. Secure back stop to table with (3) #8 x $\frac{3}{4}$ " tap screws.

! CAUTION

This machine creates a lot of wood chips/dust during operation. Breathing airborne dust on a regular basis can result in permanent respiratory illness. Reduce your risk by wearing a respirator and capturing the dust with a dust-collection system.

Minimum CFM at Dust Port: 400 CFM

Do not confuse this CFM recommendation with the rating of the dust collector. To determine the CFM at the dust port, you must consider these variables: (1) CFM rating of the dust collector, (2) hose type and length between the dust collector and the machine, (3) number of branches or wyes, and (4) amount of other open lines throughout the system. Explaining how to calculate these variables is beyond the scope of this manual. Consult an expert or purchase a good dust collection "how-to" book.

To connect dust collection system to machine:

1. Fit 4" dust hose over dust port, as shown in **Figure 32**, and secure in place with hose clamp.

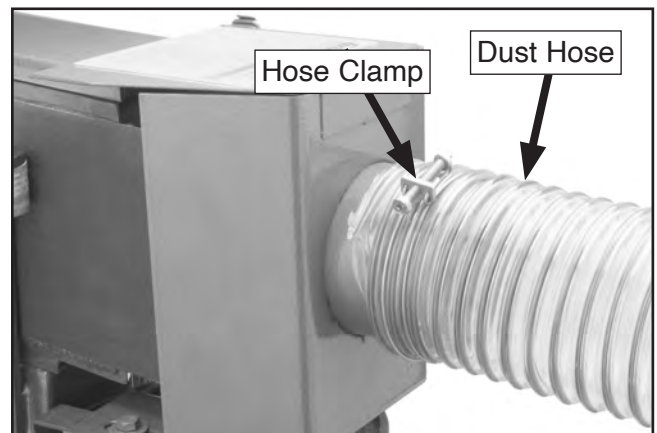

Figure 32. Example of dust hose attached to dust port.

2. Tug hose to make sure it does not come off.

Note: A tight fit is necessary for proper performance.





SECTION 4: OPERATIONS

Operation Overview

The purpose of this overview is to provide the novice machine operator with a basic understanding of how the machine is used during operation, so the machine controls/components discussed later in this manual are easier to understand.

Due to the generic nature of this overview, it is **not** intended to be an instructional guide. To learn more about specific operations, read this entire manual, seek additional training from experienced machine operators, and do additional research outside of this manual by reading "how-to" books, trade magazines, or websites.

	<p>!WARNING To reduce your risk of serious injury, read this entire manual BEFORE using machine.</p>
------------------------------------------------------------------------------------	------------------------------------------------------------------------------------------------------------------------

<p>!WARNING To reduce risk of eye injury from flying chips or lung damage from breathing dust, always wear safety glasses and a respirator when operating this machine.</p>	
	

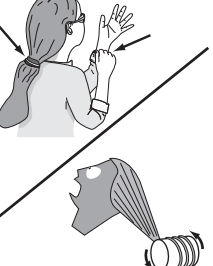
	<p>!WARNING Keep hair, clothing, and jewelry away from moving parts at all times. Entanglement can result in death, amputation, or severe crushing injuries!</p>
-------------------------------------------------------------------------------------	-----------------------------------------------------------------------------------------------------------------------------------------------------------------------------

NOTICE

If you are not experienced with this type of machine, **WE STRONGLY RECOMMEND** that you seek additional training outside of this manual. Read books/magazines or get formal training before beginning any projects. Regardless of the content in this section, Grizzly Industrial will not be held liable for accidents caused by lack of training.

To complete a typical operation, the operator does the following:

1. Examines workpiece to make sure it is suitable for sanding. No extreme bows, knots, or cracks should exist.
2. Prepares and trims workpiece as necessary.
3. Installs sanding belt with appropriate grit for operation.
4. Adjusts table height as necessary for operation.
5. Ties back loose hair and clothing, and puts on safety glasses and respirator. Takes all other required safety precautions.
6. Starts sander and dust collection system.
7. With both hands, holds workpiece firmly and flatly against table and back stop, and gradually eases workpiece into sanding belt.
8. Stops machine and dust collection system.



Workpiece Inspection

Some workpieces are not safe to sand or may require modification before they are safe to sand.

Before sanding, inspect all workpieces for the following:

- **Material Type:** This machine is intended for sanding natural and man-made wood products. This machine is NOT designed to sand metal, glass, stone, tile, plastics, drywall, cement backer board, laminate products, etc.

Sanding improper materials increases risk of respiratory harm to operator and bystanders due to especially fine dust inherently created by all types of sanding operations—even if a dust collector is used. Additionally, life of machine and sanding belts will be greatly reduced (or immediately damaged) from sanding improper materials or from exposure to fine dust created when doing so.

- **Foreign Objects:** Nails, staples, dirt, rocks, and other foreign objects are often embedded in wood. While sanding, these objects can become dislodged and tear sanding belt. Always visually inspect your workpiece for these items. If they can't be removed, DO NOT sand the workpiece.
- **Wet or "Green" Stock:** Sanding wood with a moisture content over 20% causes unnecessary clogging and wear on the sanding belt, increases the risk of kickback, and yields poor results.

Sanding Tips

- Avoid sanding a workpiece more than is necessary, since doing so will unnecessarily decrease belt life and cost you more money over time.
- Extend the life of sanding belts by regularly using a PRO-STIK® abrasive surface cleaner (see **Cleaning Sanding Belt** on **Page 33**).
- As a rule-of-thumb, sand with progressively higher grit numbers in increments of 50 or less.
- Replace sandpaper with a higher grit to achieve a finer finish (refer to **Installing/Changing Sanding Belts** on **Page 26**).
- Hold the workpiece securely with both hands. Use the table and back stop whenever possible to support workpieces. Do not force the workpiece against the belt.
- When sanding workpieces with a bow or crown, place the high point up on the table to prevent the workpiece from rocking, then take very light passes.
- Use the full width of the sanding belt by adjusting the table height or workpiece position so sanding is not always done in just one area.
- Belts clog and wear. Change belts whenever you notice a difference in sanding quality/performance.

WARNING

Moving belt can cause serious personal injury if it comes in contact with fingers, hands, or other body parts. Always support workpiece against table and back stop when sanding. Use extreme care to provide a safe distance between belt and any body parts.



Choosing Sanding Belts

The Model G0512 uses a 6" x 80" sanding belt.

We recommend using aluminum-oxide sanding belts for best results. The grit you choose will depend on the condition and species of wood, and the level of finish you wish to achieve.

Grit	Class	Usage
36	Extra Coarse	Rough sawn boards, thickness sanding, and glue removal.
60	Coarse	Thickness sanding and glue removal.
80–100	Medium	Removing marks and initial finish sanding.
120–180	Fine	Finish sanding.

The general rule of thumb is to sand a workpiece with progressively higher grit numbers—in increments of 50 or less. Avoid skipping grits; the larger the grit increase at one time, the harder it will be to remove the scratches from the previous grit.

Note: Sandpaper finer than 180-grit will easily load up or burn the workpiece.

Installing/Changing Sanding Belts

The sanding belt should be replaced whenever there is a noticeable change in sanding quality/performance. You may also need to change grit sizes of sanding belt for quick material removal or finer finishes.

Required Sanding Belt Size6" x 80"

To install/change sanding belt:

1. DISCONNECT MACHINE FROM POWER!

2. Loosen tension/tracking lock knob, then move belt tension lever toward motor to release tension (see **Figure 33**).

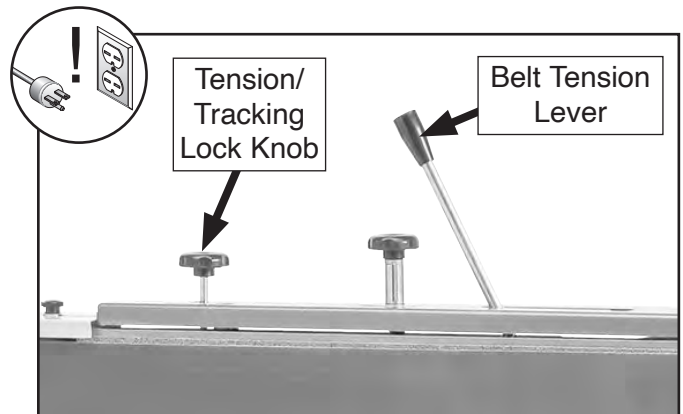

Figure 33. Location of tension/tracking lock knob and tension lever.

3. Loosen knob shown in **Figure 34** to remove roller guard.

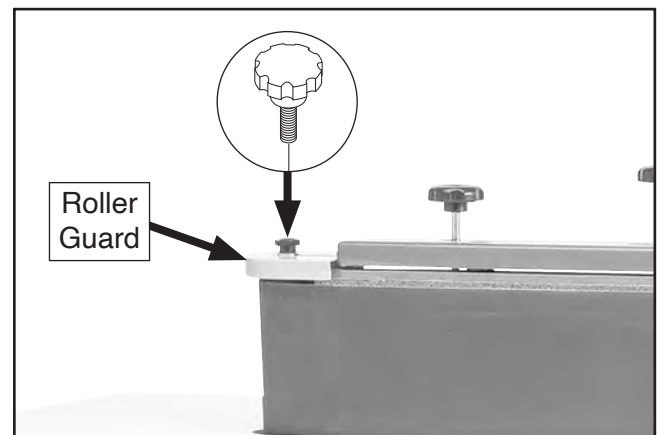

Figure 34. Location of roller guard and knob.

4. Unlatch and open dust port cover shown in **Figure 35**.

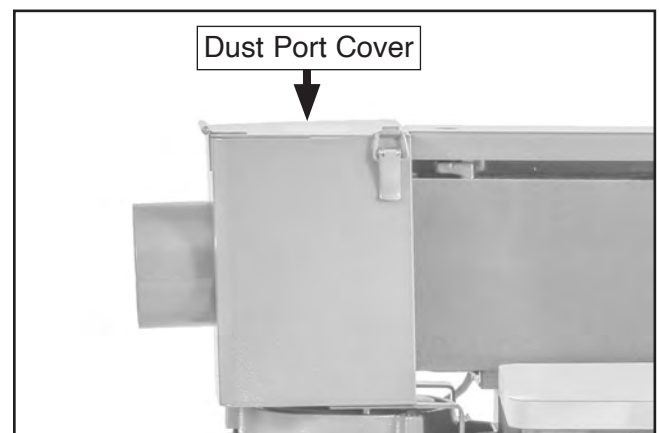

Figure 35. Location of dust port cover.



- Remove old sanding belt and replace with new one, being sure arrows on inside of belt point in counterclockwise direction, as shown in **Figure 36**.

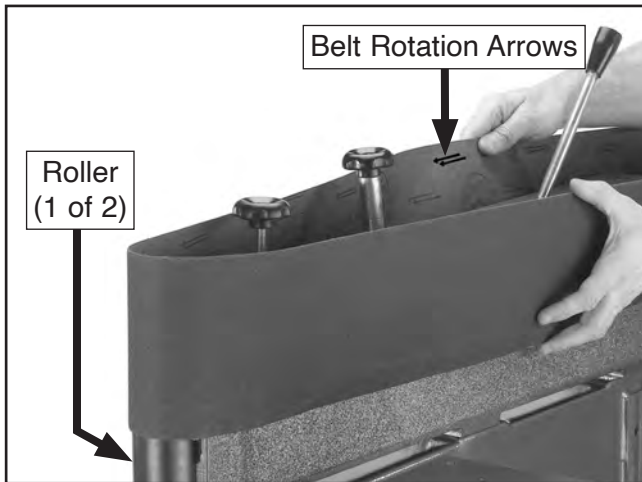

Figure 36. Installing sanding belt on rollers.

- Move belt tension lever away from motor to tension belt.
- Belt **MUST** be pre-tracked before connecting machine to power. Proceed to **Pre-Tracking Belt**.

Pre-Tracking Belt

You must perform this procedure after installing a sanding belt to ensure that the belt does not come off or get jammed against the sanding belt frame.

To pre-track belt:

- DISCONNECT MACHINE FROM POWER!
- Install sanding belt as described in **Installing/Changing Sanding Belts** on **Page 26**.

⚠ CAUTION

Fingers and other body parts can be quickly injured if they touch moving sanding surfaces. To reduce this risk, wear gloves while manually pushing belt.

- Standing in front of sander, manually push sanding belt multiple times along platen, so that it moves in direction of operation (counterclockwise on rollers), then watch how belt tracks on rollers.
- Adjust belt tracking knob while continuing to rotate belt by hand until belt rides even with top of drive roller (see **Figures 37–38**).

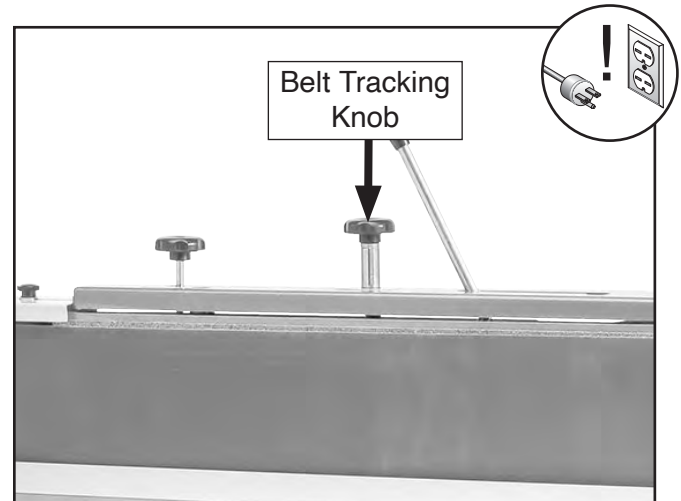

Figure 37. Location of belt tracking knob.



Figure 38. Sanding belt even with top of drive roller (dust port removed for clarity).

- Remove gloves.
- ⚠ WARNING:** DO NOT wear gloves while operating sander. Gloves could be caught in moving parts.
- Proceed to **Checking/Adjusting Belt Tracking** on **Page 28** to complete belt tracking.



Checking/Adjusting Belt Tracking

The purpose of belt tracking is to make sure the belt stays centered on the rollers and platen during sanding operations. The belt tracking needs to be checked any time you change or replace the belt.

If belt tracking is not adjusted properly, the belt can be damaged and present a serious safety hazard if it moves off of the rollers and throws material when it contacts the belt guard and other components.

To check/adjust belt tracking:

1. Install desired sanding belt as described in **Installing/Changing Sanding Belts** on **Page 26**.
2. Pre-track sanding belt as described in **Pre-Tracking Belt** on **Page 27**.
3. Connect machine to power, then turn machine **ON** and observe belt tracking across rollers and platen.
 - If top of belt *does* stay even with top of drive roller (see **Figure 39**), no adjustment is necessary.
 - If top of belt *does not* stay even with top of drive roller, proceed to **Step 4**.

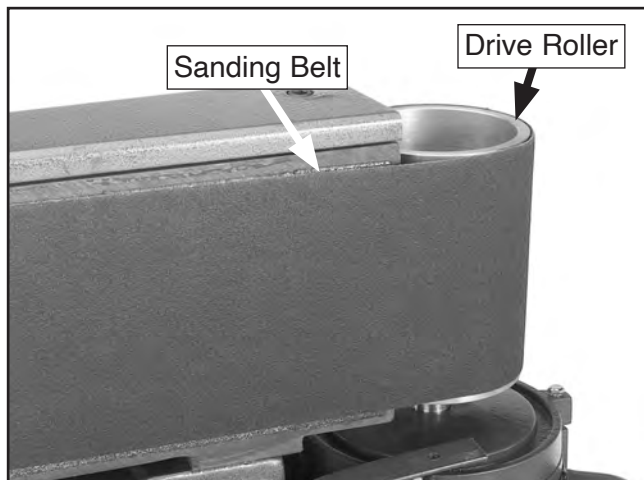

Figure 39. Sanding belt even with top of drive roller (dust port removed for clarity).

4. Adjust belt tracking knob (see **Figure 40**) to adjust belt higher or lower on rollers until top of belt remains even with top of drive roller.

Note: *Belt tracking knob is very sensitive; adjust it in small increments.*

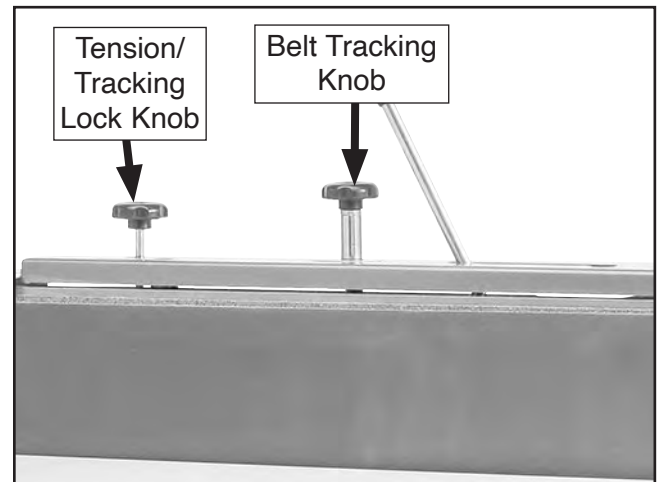

Figure 40. Location of belt tracking knob and tension/tracking lock knob.

5. When belt tracking appears to be correct, allow machine to run for approximately one minute to verify tracking stays in correct position, then turn machine **OFF**.
 - If tracking does not stay in correct position, repeat **Steps 4–5**.
6. Tighten tension/tracking lock knob to secure tracking setting (see **Figure 40**).
7. Close and latch dust port cover.
8. Install roller guard.



Adjusting Table Height

The table can be adjusted up or down to allow the operator to use more surface area of the sanding belt. Adjusting the height will also prevent the platen graphite and sanding belt from wearing out in one place.

To adjust table height:

1. Loosen (4) table lock handles (see **Figure 41**).
2. Turn table height handwheel to raise or lower table to desired height (see **Figure 41**).

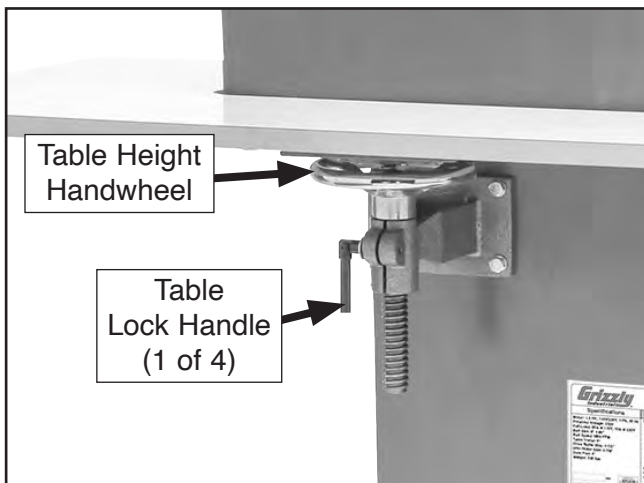

Figure 41. Table height controls.

3. Tighten table lock handles to secure.

Edge & End Sanding

Edge and end sanding operations are performed on the table with the workpiece pressing against the platen. Always use the back stop to support the workpiece whenever possible.

⚠WARNING

Moving sanding belt can cause serious personal injury if it comes in contact with hands, fingers, or other body parts. Make sure workpiece is always supported against table. Use extreme care to provide safe distance between belt and any part of body.

⚠WARNING

If you must feed workpiece into sanding belt corner first, feed trailing corner first. Feeding leading corner could cause sanding belt to grab workpiece and jerk it out of your hands.

To edge or end sand:

1. Adjust table to desired height (refer to **Adjusting Table Height**).
2. Connect machine to power, turn it **ON**, and allow it to reach full speed.
3. Support workpiece against back stop and slowly feed workpiece into moving belt with light, even pressure. Maintain control of workpiece, as shown in **Figures 42–43**. **DO NOT** force workpiece against belt.



Contour Sanding

Contour sanding operations are performed on the table with the workpiece pressing against the idler roller. Always use two hands to maintain the best control.

To contour sand:

1. Adjust table to desired height (refer to **Adjusting Table Height** on **Page 29**).
2. Connect machine to power, turn it **ON**, and allow it to reach full speed.
3. While securely holding workpiece, slowly feed workpiece into curved end with light, even pressure. While maintaining control of workpiece, as shown in **Figure 44**, move workpiece profile along roller contour until you achieve desired shape. **DO NOT** force workpiece against belt.



Figure 42. Typical edge sanding operation.



Figure 43. Typical end sanding operation.

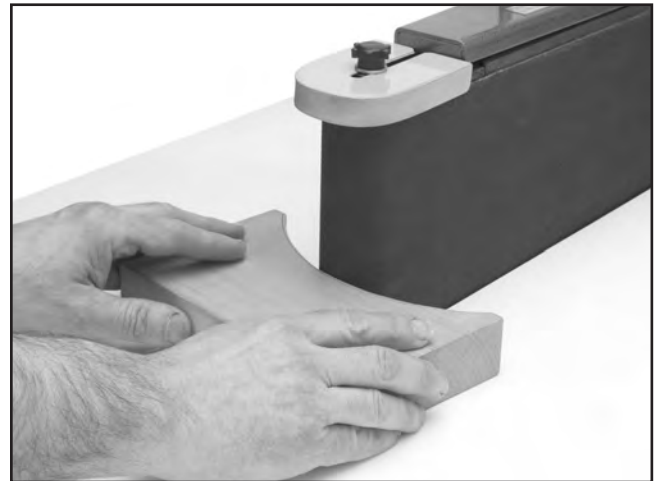

Figure 44. Typical contour sanding operation.



SECTION 5: ACCESSORIES

! WARNING

Installing unapproved accessories may cause machine to malfunction, resulting in serious personal injury or machine damage. To reduce this risk, only install accessories recommended for this machine by Grizzly.

NOTICE

Refer to our website or latest catalog for additional recommended accessories.

A/O Sanding Belts 6" x 80" (2-Pk)

- D1263—60-Grit
- D1264—80-Grit
- D1265—100-Grit
- D1266—120-Grit
- D1267—150-Grit
- D1268—180-Grit
- D1269—220-Grit

These belts feature tough aluminum oxide grain and are sized for the Model G0512.



Figure 45. D1263 60-Grit Sanding Belts.

Basic Eye Protection

T32323—Woodturners Face Shield

T32401—EDGE Brazeau Safety Glasses, Clear

T32402—EDGE Khor G2 Safety Glasses, Tint

T32404—EDGE Mazeno Safety Glasses, Clear



Figure 46. Assortment of basic eye protection.

G0538— $\frac{1}{3}$ HP Oscillating Spindle Sander

Nothing beats the versatility of this sander when it comes to sanding the edges of contoured or irregularly-shaped workpieces. It features a 14" x 20" table, 2½" dust port, six different drum diameters, and 6 table inserts.

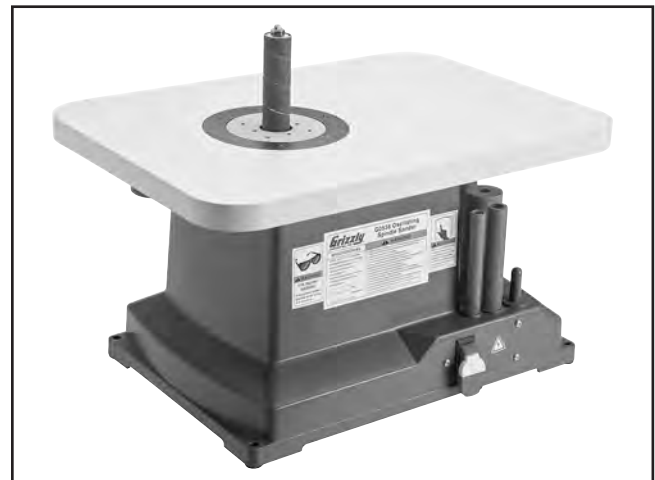

Figure 47. G0538 $\frac{1}{3}$ HP Oscillating Spindle Sander.

order online at www.grizzly.com or call 1-800-523-4777



G0860—1½ HP Portable Cyclone Dust Collector

This dust collector features an impressive 868 CFM and up to 9.7" of static pressure, a 12¾" aluminum impeller, and a spun-bond polyester filter that catches 99.9% of particles up to 1-micron.



Figure 48. G0860 1½ HP Portable Air Compressor.

D4206—Clear Flexible Hose 4" x 10'

D4256—45° Elbow 4"

D4216—Black Flexible Hose 4" x 10'

W1034—Heavy-Duty Clear Flex Hose 4" x 10'

D2107—Hose Hanger 4 ¼"

W1015—Y-Fitting 4" x 4" x 4"

W1017—90° Elbow 4"

W1019—Hose Coupler (Splice) 4"

W1317—Wire Hose Clamp 4"

W1007—Plastic Blast Gate 4"

W1053—Anti-Static Grounding Kit

Hand-picked selection of commonly used dust collection components for 4" dust ports.

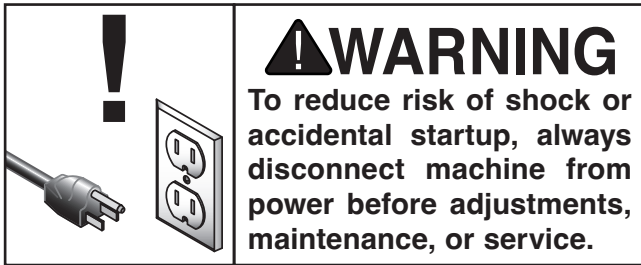

Figure 49. Dust collection accessories.

order online at www.grizzly.com or call 1-800-523-4777



SECTION 6: MAINTENANCE



Schedule

For optimum performance from this machine, this maintenance schedule must be strictly followed.

Ongoing

To minimize your risk of injury and maintain proper machine operation, shut down the machine immediately if you ever observe any of the items below, and fix the problem before continuing operations:

- Loose mounting bolts.
- Damaged sanding belt.
- Worn or damaged wires.
- Any other unsafe condition.

Monthly

- Lubricate belt tension shaft.
- Remove belt and clean/vacuum dust buildup from behind platen and off of motor.

Cleaning & Protecting

Cleaning the Model G0512 is relatively easy. Vacuum excess wood chips and sawdust, and wipe off the remaining dust with a dry cloth. If any resin has built up, use a resin dissolving cleaner to remove it.

DO NOT expose the underside of the table because it may warp.

Cleaning Sanding Belt

As sanding belts are used, they will quickly become "loaded" with sawdust. If not removed, this sawdust will harden on the abrasive surface, rendering the belts useless. Routinely clean the sanding belts with a rubber gum abrasive cleaner as shown in **Figure 50**.

PRO-STIK® Abrasive Surface Cleaners

W1306—1½" x 1½" x 8½"

W1307—2" x 2" x 12"

Extend the life of your sanding belts! Choose the PRO-STIK® with a handle for greater control or without a handle for more usable area.



Figure 50. PRO-STIK® abrasive surface cleaners.

Always discard worn sanding belts. As abrasive belts begin to wear, grit will begin to fall off, causing deep gouges in the workpiece. Glue used to hold the grit to the belt will rub off onto the workpiece, causing burns and interference with final finishing.

NOTICE

Contrary to some beliefs, worn abrasive belts are not equivalent to next finer grit abrasive. Discard worn sanding belts and avoid temptation to use them beyond their usable life.



Lubrication

An essential part of lubrication is cleaning the components before lubricating them. This step is critical because dust builds up on lubricated components, which makes them hard to move. Simply adding more grease will not result in smooth moving parts. Clean the components in this section with an oil-grease solvent cleaner or mineral spirits before applying lubrication.

All the bearings are sealed and permanently lubricated. Leave them alone until they need to be replaced.

T26685—ISO 32 Moly-D Machine Oil, 1 Gal.
Moly-D oils are some of the best we've found for maintaining the critical components of machinery because they tend to resist run-off and maintain their lubricity under a variety of conditions.



Figure 51. T26685 ISO 32 Moly-D Machine Oil.

T26419—Syn-O-Gen Synthetic NLGI#2 Grease
Formulated with 100% pure synthesized hydrocarbon basestocks that are compounded with special thickeners and additives to make Syn-O-Gen non-melt, tacky, and water resistant. Extremely low pour point, extremely high temperature oxidation, and thermal stability produce a grease that is unmatched in performance.



Figure 52. T26419 Syn-O-Gen Synthetic Grease.

Tension Shaft

Lubrication TypeT26685 or ISO 32 Equiv.
AmountFew Drops
Frequency.....Monthly

Apply a few drops of light machine oil at the locations indicated in **Figure 53**. Move the belt tension lever back and forth a few times to spread the oil evenly.

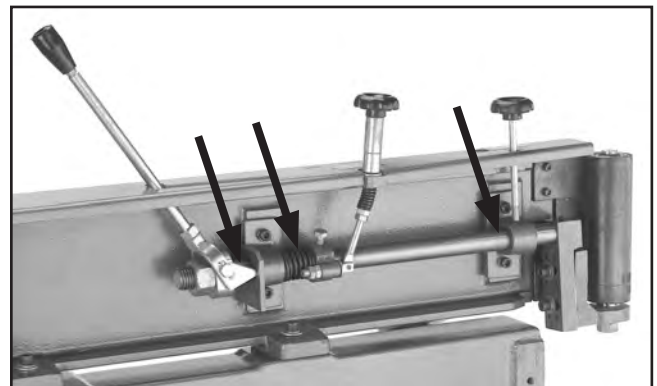

Figure 53. Tension shaft lubrication locations.

Table Height Leadscrew

Lubrication Type T26419 or NLGI #2 Equiv.
AmountThin Coat
Frequency..... As Needed

Items Needed	Qty
Wire Brushes.....	2
Shop Rags.....	As Needed
Mineral Spirits.....	As Needed

Clean the threads of the table height leadscrew (see **Figure 54**) with a wire brush, rag, and mineral spirits. Brush new lubricant on threads with a clean brush and move the table up and down a few times to evenly distribute the lubricant.

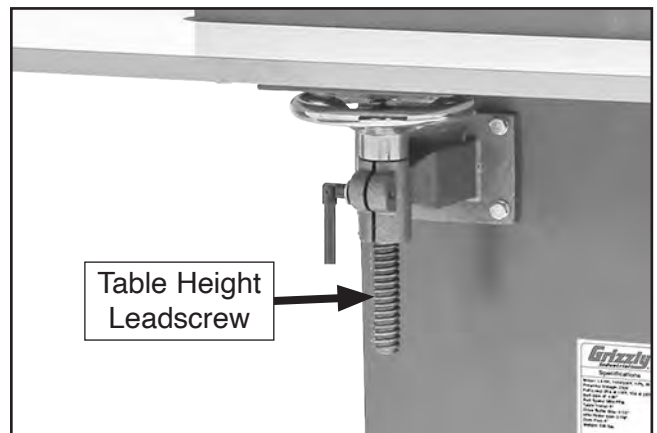

Figure 54. Location of table height leadscrew.



SECTION 7: SERVICE

Review the troubleshooting procedures in this section if a problem develops with your machine. If you need replacement parts or additional help with a procedure, call our Technical Support. **Note:** *Please gather the serial number and manufacture date of your machine before calling.*

Troubleshooting

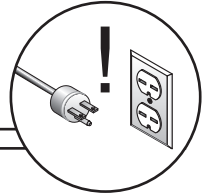

Motor & Electrical

Symptom	Possible Cause	Possible Solution
Machine does not start, or power supply breaker immediately trips after startup.	<ol style="list-style-type: none"> 1. Switch disabling key is removed. 2. Incorrect power supply voltage or circuit size. 3. Plug/receptacle at fault/wired incorrectly. 4. Power supply circuit breaker tripped or fuse blown. 5. Motor wires connected incorrectly. 6. Start capacitor at fault. 7. Centrifugal switch adjustment/contact points at fault. 8. Wiring broken, disconnected, or corroded. 9. ON/OFF switch at fault. 10. Motor or motor bearings at fault. 	<ol style="list-style-type: none"> 1. Install switch disabling key. 2. Ensure correct power supply voltage and circuit size (Page 11). 3. Test for good contacts; correct wiring (Page 45). 4. Ensure circuit is free of shorts. Reset circuit breaker or replace fuse. 5. Correct motor wiring connections (Page 45). 6. Test/replace if at fault. 7. Adjust centrifugal switch/clean contact points. Replace either if at fault. 8. Fix broken wires or disconnected/corroded connections (Page 45). 9. Replace switch. 10. Replace motor.
Machine stalls or is underpowered.	<ol style="list-style-type: none"> 1. Workpiece material unsuitable for machine. 2. Motor wires connected incorrectly. 3. Plug/receptacle at fault/wired incorrectly. 4. Machine undersized for task. 5. Motor overheated. 6. Extension cord too long. 7. Centrifugal switch/contact points at fault. 8. Motor or motor bearings at fault. 	<ol style="list-style-type: none"> 1. Only sand wood/ensure moisture is below 20% (Page 25). 2. Correct motor wiring connections (Page 45). 3. Test for good contacts/correct wiring (Page 45). 4. Clean (Page 33)/replace sandpaper (Page 26); reduce feed rate/sanding depth. 5. Clean motor, let cool, and reduce workload. 6. Move machine closer to power supply; use shorter extension cord (Page 12). 7. Adjust centrifugal switch/clean contact points. Replace either if at fault. 8. Replace motor.
Machine has vibration or noisy operation.	<ol style="list-style-type: none"> 1. Motor or component loose. 2. Machine feet not installed properly. 3. Drive roller hex nut is missing or loose. 4. Motor mount loose/broken. 5. Motor fan rubbing on fan cover. 6. Centrifugal switch needs adjustment/at fault. 7. Motor bearings at fault. 	<ol style="list-style-type: none"> 1. Replace damaged or missing bolts/nuts or tighten if loose. 2. Adjust machine feet to stabilize machine. 3. Replace or tighten if loose. 4. Tighten/replace. 5. Fix/replace fan cover; replace loose/damaged fan. 6. Adjust/replace if at fault. 7. Test by rotating shaft; rotational grinding/loose shaft requires bearing replacement.



Operation

Symptom	Possible Cause	Possible Solution
Sanding belt slaps or vibrates excessively.	<ol style="list-style-type: none"> 1. Sanding belt is not tensioned. 2. Belt tracking needs adjustment. 3. Broken/defective sanding belt. 4. Idler or drive roller is loose. 5. Incorrect sanding belt tension. 6. Weak or broken tension spring. 	<ol style="list-style-type: none"> 1. Make sure belt tension lever is engaged. 2. Adjust sanding belt tracking (Page 28). 3. Replace sanding belt (Page 26). 4. Tighten idler or drive roller. 5. Adjust belt tensioner (Page 37). 6. Replace spring.
Belt does not track correctly.	<ol style="list-style-type: none"> 1. Belt tracking needs adjustment. 2. Incorrect sanding belt tension. 3. Belt damaged, worn, or misshapen. 	<ol style="list-style-type: none"> 1. Adjust sanding belt tracking (Page 28). 2. Make sure belt tension lever is engaged. Adjust belt tensioner (Page 37). 3. Replace sanding belt (Page 26).
Deep grooves or scores in workpiece.	<ol style="list-style-type: none"> 1. Using too coarse of sanding grit. 2. Workpiece sanded across grain. 3. Too much pressure against belt. 4. Workpiece held still for too long. 5. Graphite pad on platen damaged. 	<ol style="list-style-type: none"> 1. Use finer grit sanding belt (Page 26). 2. Sand with workpiece grain. 3. Reduce pressure on workpiece while sanding. 4. Do not keep workpiece in one place for too long. 5. Replace graphite pad.
Abrasive grit rubs off belt easily.	<ol style="list-style-type: none"> 1. Sanding belt has been stored in an incorrect environment. 2. Sanding belt has been folded or crushed. 	<ol style="list-style-type: none"> 1. Replace sanding belt (Page 26). Store sanding belt in a cool, dry area. 2. Replace sanding belt (Page 26). Store sanding belt flat, not folded or bent.
Sanding belt surfaces clog quickly or burn.	<ol style="list-style-type: none"> 1. Worn sanding belt. 2. Too much pressure against belt. 3. Sanding softwood. 4. Workpiece has high moisture content or sap. 5. Using too fine of sanding grit. 6. Poor dust collection. 	<ol style="list-style-type: none"> 1. Replace sanding belt (Page 26). 2. Reduce pressure on workpiece while sanding. 3. Use different stock or accept characteristics of workpiece and plan on cleaning (Page 33)/replacing belt frequently (Page 26). 4. Use different stock or accept characteristics of workpiece and plan on cleaning (Page 33)/replacing belt frequently (Page 26). 5. Use coarser grit sanding belt (Page 26). 6. Unclog ducts; close gates to improve suction; redesign dust collection system.
Burn marks on workpiece.	<ol style="list-style-type: none"> 1. Using too fine of sanding grit. 2. Too much pressure against belt. 3. Workpiece held still for too long. 4. Sanding belt loaded with sawdust, resin, and/or pitch. 	<ol style="list-style-type: none"> 1. Use coarser grit sanding belt (Page 26). 2. Reduce pressure on workpiece while sanding. 3. Do not keep workpiece in one place for too long. 4. Clean (Page 33) or replace belt (Page 26).
Glazed sanding surfaces.	<ol style="list-style-type: none"> 1. Sanding wet stock. 2. Sanding stock with high pitch/residue. 3. Belt worn or filled with pitch/residue. 	<ol style="list-style-type: none"> 1. Dry properly before sanding (Page 25). 2. Use different stock or accept characteristics of workpiece and plan on cleaning (Page 33)/replacing belt frequently (Page 26). 3. Replace belt (Page 26) or clean pitch/residue from belt (Page 33).
Workpiece frequently gets pulled out of your hand.	<ol style="list-style-type: none"> 1. Not supporting workpiece properly. 2. Starting workpiece on a leading corner. 	<ol style="list-style-type: none"> 1. Use back stop to support workpiece. 2. Start workpiece on a trailing corner.
Snake-shaped marks on workpiece.	<ol style="list-style-type: none"> 1. Sanding belt loaded with sawdust, resin, and/or pitch. 2. Sanding belt damaged. 	<ol style="list-style-type: none"> 1. Clean (Page 33) or replace belt (Page 26). 2. Replace sanding belt (Page 26).



Adjusting Belt Tensioner

The belt tensioner is normally adjusted as the belt stretches. Two good indications of belt stretch (or a loose belt) are when the belt slaps against the platen while running or it slips on the rollers. On the other hand, if the belt tension is too tight, you will have a hard time installing and removing the belt when the tension is released.

Tools Needed	Qty
Open-End Wrench 1½"	1

To adjust belt tensioner:

1. DISCONNECT MACHINE FROM POWER!
2. Unlatch and open dust port cover shown in **Figure 55**.

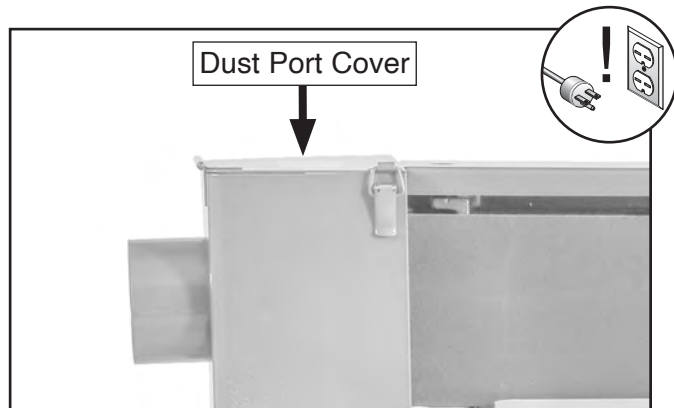

Figure 55. Location of dust port cover.

3. Loosen knob shown in **Figure 56** to remove roller guard.

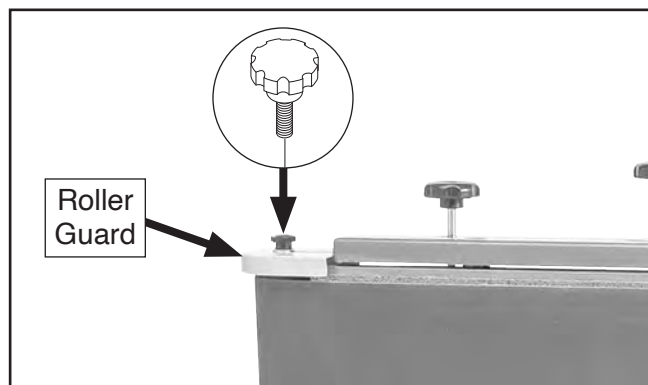

Figure 56. Location of roller guard and knob.

4. Lower table as far as it will go.
5. Remove sanding belt.
6. Move belt tension lever to tensioned position.
7. Rotate tension nut counterclockwise to increase belt tension or clockwise to decrease belt tension (see **Figure 57**).

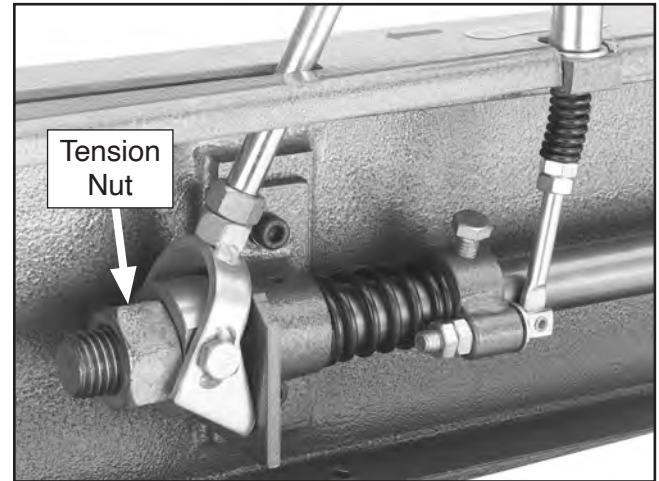

Figure 57. Location of tension nut.

— *Decreasing Belt Tension:* If you rotated tension nut clockwise, move belt tension lever to release position. If lever is not too stiff, proceed to **Step 8**. If lever is too stiff to move comfortably, then either shaft spring tension needs to be reset (refer to **Resetting Tension Shaft Spring** on **Page 38**), tension shaft needs to be lubricated (see **Page 34**), or platen-to-idler roller relationship needs to be adjusted (refer to **Platen-to-Roller Adjustments** on **Page 40**).

— *Increasing Belt Tension:* If you rotated tension nut counterclockwise, check beginning movement of belt tension lever. If there *is no* play in first 2" of travel, continue to **Step 8**. If there *is* play in first 2" of travel, then tension shaft spring needs to be reset (refer to **Resetting Tension Shaft Spring** on **Page 38**).

8. Install sanding belt and examine effect of tension adjustment on belt. Repeat **Steps 5–7**, if necessary.
9. Close dust port cover and install roller guard.



Resetting Tension Shaft Spring

The tension shaft spring applies pressure to the sanding belt when the belt tension lever is in the tension position. When repeated adjustments are made to the tension nut, the spring tension may lose the original setting from the factory, at which point it will need to be reset.

Items Needed	Qty
Open-End Wrench 1½"	1
Wrench or Socket 14mm	1
Assistant	1

To reset tension shaft spring:

1. DISCONNECT MACHINE FROM POWER!
2. Unlatch and open dust port cover shown in **Figure 58**.

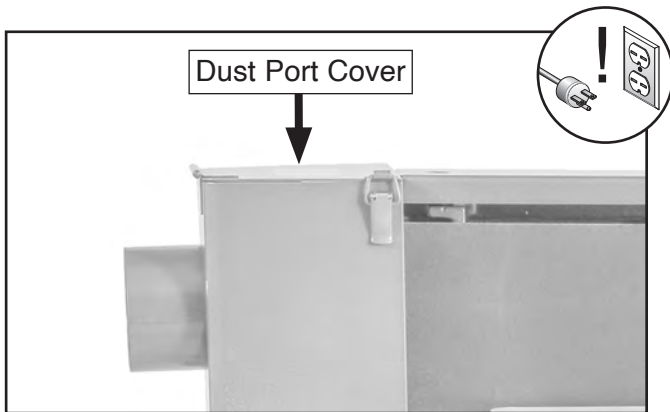

Figure 58. Location of dust port cover.

3. Loosen knob shown in **Figure 59** to remove roller guard.

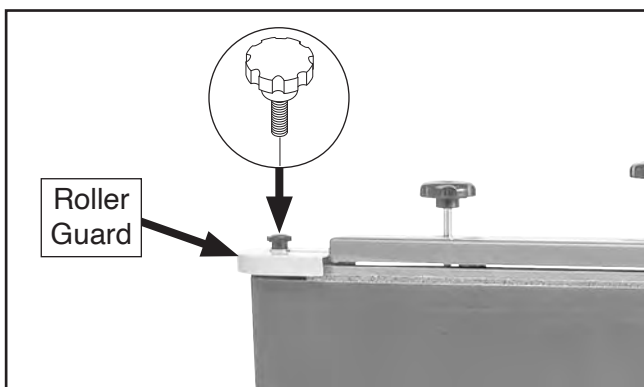

Figure 59. Location of roller guard and knob.

4. Remove (4) table lock handles in order to remove table from machine.

Note: L-brackets and leadscrew table bracket should still be attached to table.

5. Remove sanding belt.
6. Move belt tension lever to tensioned position.
7. Rotate tension nut counterclockwise until threads of tension shaft are flush with nut (see **Figure 60**).
8. Loosen tracking control bolt (see **Figure 60**).

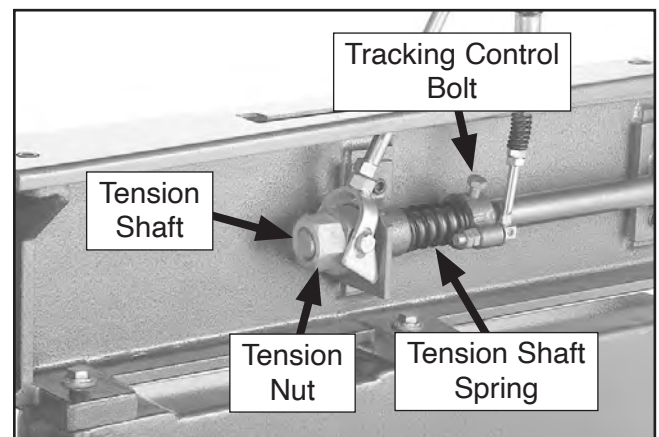

Figure 60. Tension nut flush with tension shaft threads.

9. Have assistant pull idler roller to remove slack in shaft, then tighten tracking control bolt.
10. Turn tension nut clockwise approximately 3 full turns.
11. Engage and disengage belt tension lever, then tighten tension nut 2 more full turns.
12. Check/adjust platen-to-idler roller relationship as described in **Steps 7–8 of Checking Platen-to-Roller Relationships** beginning on **Page 40**.

13. Install table.

Note: It may be necessary to slightly adjust tension nut to make table fit.

14. Install and track sanding belt, then close dust port cover and install roller guard.



Checking/Adjusting Parallel Belt Tracking

The belt should track on the rollers so that the top edge of the sanding belt stays parallel with the top edge of the platen graphite, as illustrated in **Figure 61**.

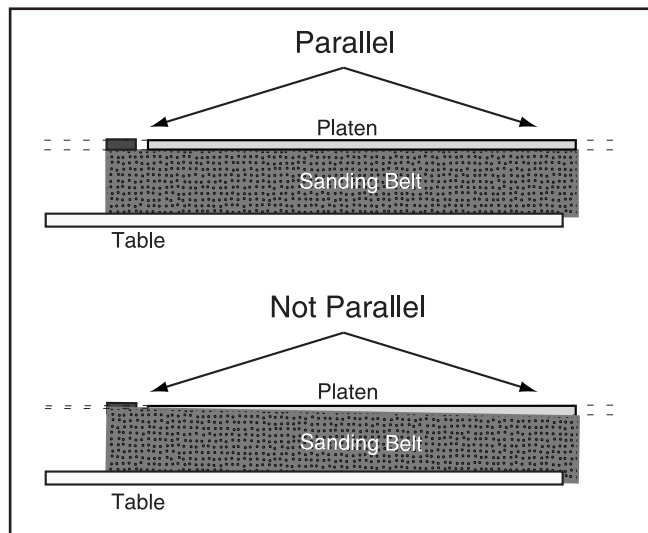

Figure 61. Illustration of parallel belt tracking.

Checking Parallel Belt Tracking

- Track belt so side of belt that is tracking higher is even with top of platen graphite.
 - If lower side of belt is *less than* 1/8" from top of graphite, then no adjustment is necessary.
 - If lower side of belt is *more than* 1/8" from top of graphite, record distance between low side of belt and top of platen, then proceed to following section.

Adjusting Parallel Belt Tracking

Tools Needed	Qty
Wrench 12mm	1
Hex Wrench 3, 8mm.....	1 Ea.
Level 12"	1

To adjust parallel belt tracking:

- DISCONNECT MACHINE FROM POWER!
- Remove (2) hex bolts and flat washers shown in **Figure 62** to remove dust port.

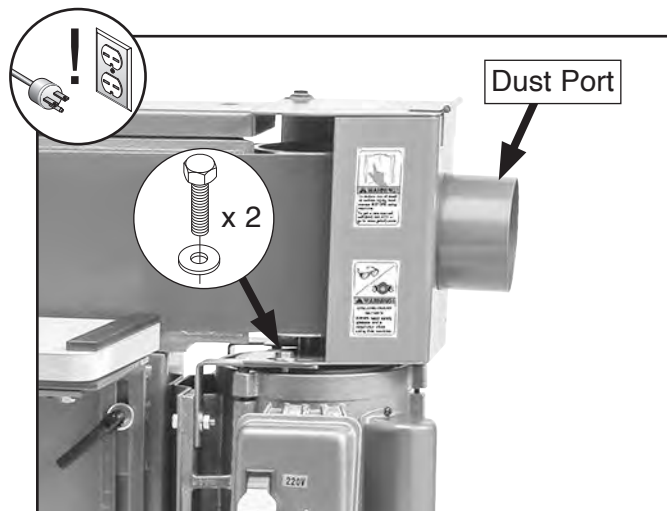

Figure 62. Location of dust port and fasteners.

- Loosen knob shown in **Figure 63** to remove roller guard.

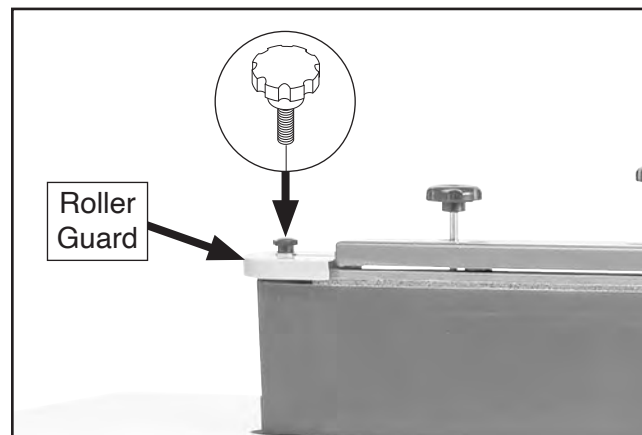

Figure 63. Location of roller guard and knob.

- Remove (4) table lock handles in order to remove table from machine.

Note: L-brackets and leadscrew table bracket should still be attached to table.

- Remove sanding belt.
- Loosen (2) cap screws shown in **Figure 64** approximately half a turn.



7. Adjust tracking set screws to adjust belt parallelism (see **Figure 64**).

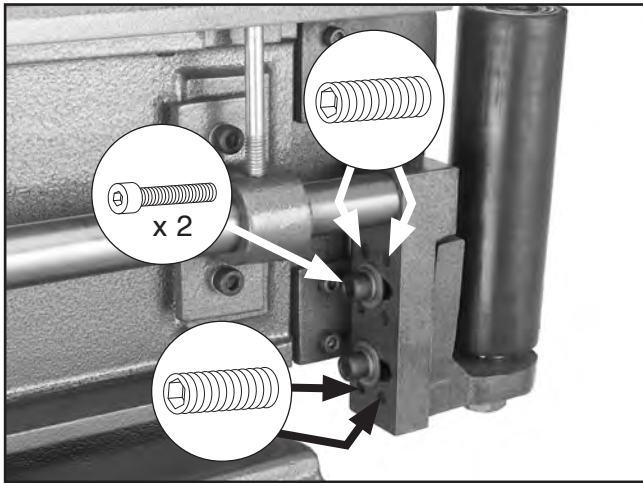

Figure 64. Location of belt parallelism adjustment screws.

- If lower side of belt is on *left* end of sander (when standing in front of sander), turn (2) lower set screws clockwise and (2) upper set screws counterclockwise the same amount.
- If lower side of belt is on *right* end of sander (when standing in front of sander), turn (2) upper set screws clockwise and (2) lower set screws counterclockwise the same amount.

8. Tighten cap screws from **Step 6**.
9. Install sanding belt, connect machine to power, then recheck parallel belt tracking.
 - If lower side of belt is *less than* $\frac{1}{8}$ " from top of graphite, then no further adjustment is necessary.
 - If lower side of belt is still *more than* $\frac{1}{8}$ " from top of graphite, **DISCONNECT MACHINE FROM POWER**, then repeat **Steps 5–8** until lower side of belt is less than $\frac{1}{8}$ " from top of graphite.
10. Install dust port and roller guard.
11. Install table.
12. Place level on table to check table is level side to side and front to back. Adjust height of L-brackets as necessary.

Platen-to-Roller Adjustments

The platen can be adjusted forward or backward in relation to the drive and idler rollers. When the platen graphite pad is correctly adjusted, it should extend beyond the rollers approximately $\frac{1}{8}$ ", as shown in **Figure 65**.

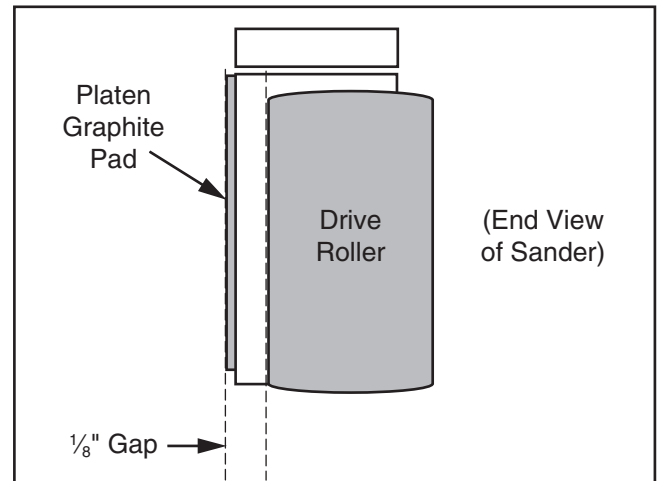

Figure 65. Platen adjusted to extend $\frac{1}{8}$ " beyond drive roller.

If the platen extends beyond this, the belt will stretch and the graphite pad will wear more quickly.

Because the idler roller is attached to the platen, it will need to be adjusted independently to complete this procedure.

Also, if the drive roller is not vertically parallel with the platen, the motor will need to be adjusted on the motor mount to complete this procedure.

Instructions for all three adjustments will be given below. First, check the platen-to-roller relationships to see if you need to make the adjustments.

Checking Platen-To-Roller Relationships

Tools Needed	Qty
Wrench 12mm	1
Straightedge 12"	1
Measuring Tape or Calipers	1



To check platen-to-roller relationships:

1. DISCONNECT MACHINE FROM POWER!
2. Remove (2) hex bolts and flat washers shown in **Figure 66** to remove dust port.

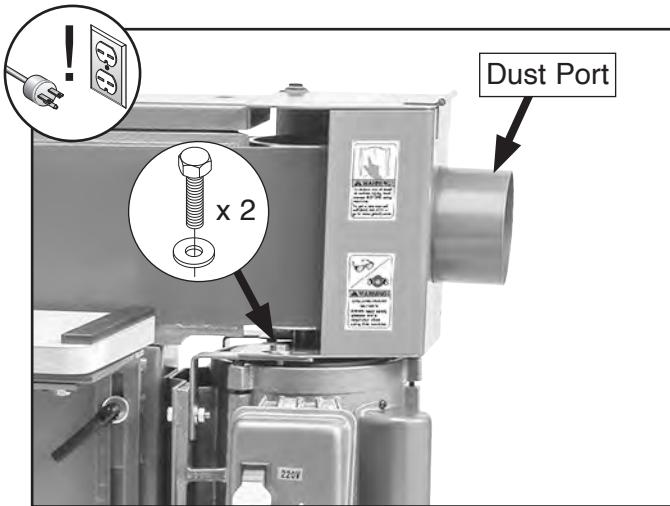

Figure 66. Location of dust port and fasteners.

3. Loosen knob shown in **Figure 67** to remove roller guard.

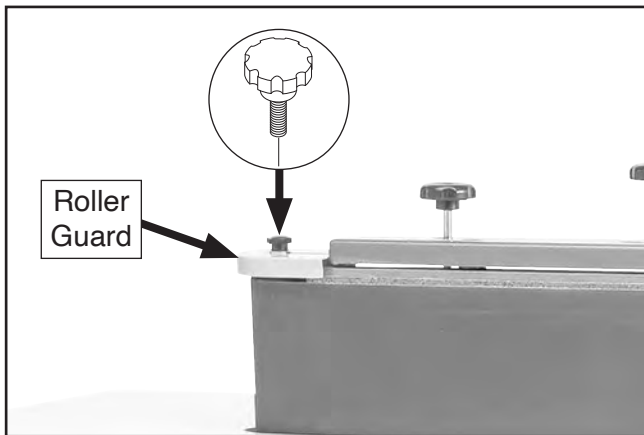

Figure 67. Location of roller guard and knob.

4. Remove sanding belt.

5. Place straightedge across TOP of platen graphite and drive roller, as shown in **Figure 68**. Record gap between straightedge and roller.



Figure 68. Checking gap between top of platen graphite and drive roller.

6. Place straightedge across BOTTOM of platen graphite and drive roller, as shown in **Figure 69**. Record gap between straightedge and roller.



Figure 69. Checking gap between bottom of platen graphite and drive roller.

— If gap between straightedge and drive roller is approximately $\frac{1}{8}$ " at top and bottom, neither platen nor drive roller need to be adjusted.



— If gap between straightedge and drive roller *is not* approximately the same at top and bottom, drive roller needs to be aligned to platen graphite before proceeding (refer to **Aligning Drive Roller to Platen**).

— If gap between straightedge and drive roller *is more or less than* approximately 1/8", but gap is approximately the same at top and bottom, platen needs to be adjusted before proceeding (refer to **Adjusting Platen** on **Page 43**).

7. Place straightedge across TOP of platen graphite and idler roller. Record gap between straightedge and roller.

8. Place straightedge across BOTTOM of platen graphite and idler roller. Record gap between straightedge and roller.

— If gap between straightedge and idler roller *is* approximately 1/8" at top and bottom, idler roller does not need to be adjusted.

— If gap between straightedge and idler roller *is not* approximately 1/8" at top and bottom, idler roller needs to be adjusted (refer to **Adjusting Idler Roller** on **Page 43**).

9. Install and track sanding belt.

10. Install roller cover and dust port.

Aligning Drive Roller to Platen

Tools Needed

	Qty
Wrenches or Sockets 12mm	2
Straightedge 12"	1
Measuring Tape or Calipers	1

To align drive roller to platen:

1. DISCONNECT MACHINE FROM POWER!
2. Loosen (4) motor mount hex bolts and hex nuts shown in **Figure 70**.

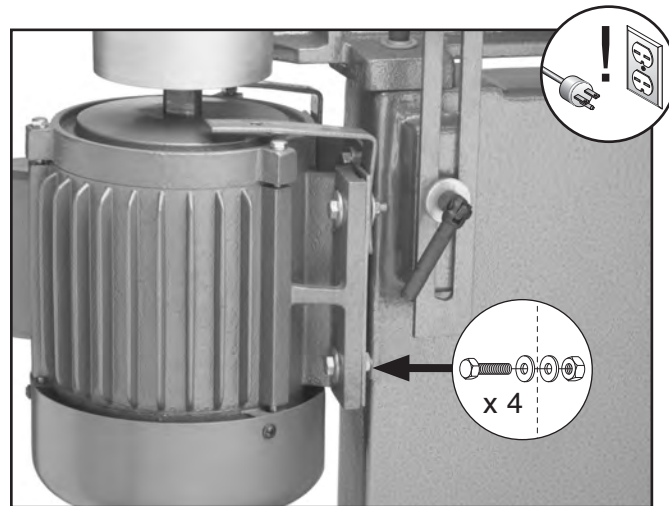

Figure 70. Location of motor mount fasteners.

3. Using straightedge, adjust drive roller so gap between platen and roller is same at bottom and top.
4. Tighten fasteners from **Step 2**, being careful not to move motor from its corrected position.
5. Repeat **Steps 5–6** of **Checking Platen-to-Roller Relationships** beginning on **Page 40**.



Adjusting Platen

Tools Needed	Qty
Wrench or Socket 14mm	1
Straightedge 12"	1
Measuring Tape or Calipers	1

The platen can also be adjusted, but this adjustment should be done carefully because moving the platen too far will force the sanding belt to press against the table.

To adjust platen:

1. DISCONNECT MACHINE FROM POWER!
2. Loosen (2) hex bolts shown in **Figure 71**.

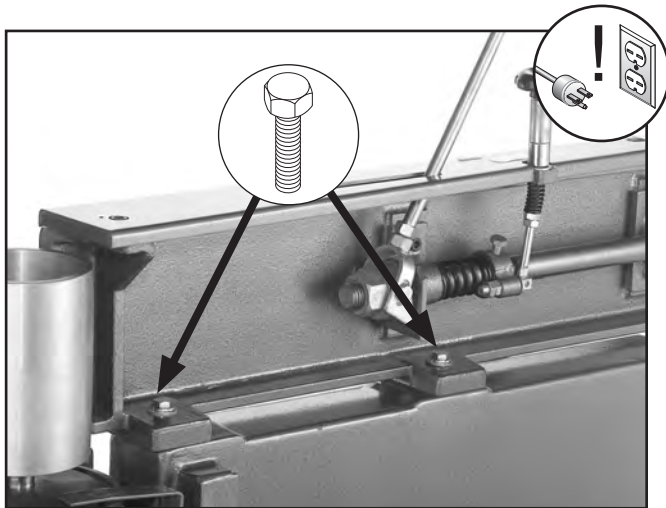

Figure 71. Location of platen adjustment hex bolts.

3. Place straightedge across platen and drive roller, then adjust platen until distance between roller and straightedge is approximately $\frac{1}{8}$ ".
4. Tighten hex bolts from **Step 2**, being careful not to move platen from its corrected position.
5. Repeat **Steps 5–6 of Checking Platen-to-Roller Relationships** beginning on **Page 40**.

Adjusting Idler Roller

Tools Needed	Qty
Hex Wrench 8mm.....	1
Straightedge 12"	1
Measuring Tape or Calipers	1

To adjust idler roller:

1. DISCONNECT MACHINE FROM POWER!
2. Loosen (2) cap screws shown in **Figure 72** approximately one full turn.

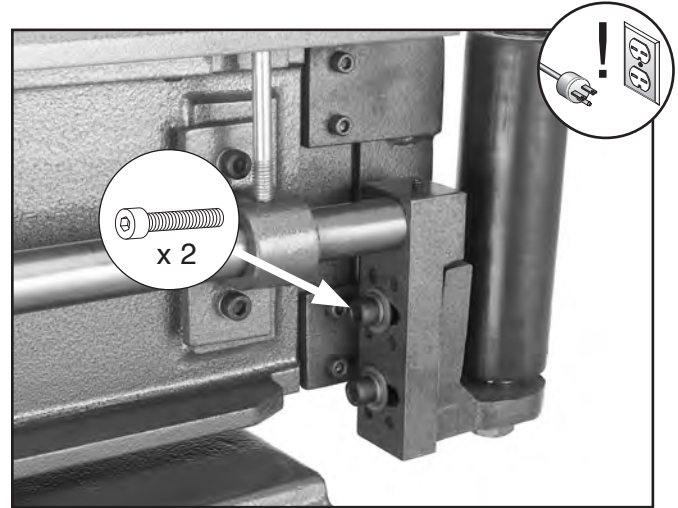

Figure 72. Location of idler roller adjustment cap screws.

3. Place straightedge across TOP of platen graphite and in front of idler roller, then adjust idler roller until it is approximately $\frac{1}{8}$ " from straightedge.
4. Place straightedge across BOTTOM of platen graphite and in front of idler roller, then adjust idler roller until it is approximately $\frac{1}{8}$ " from straightedge.
5. Tighten cap screws from **Step 2**, being careful not to move roller from its corrected position.
6. Repeat **Steps 7–8 of Checking Platen-to-Roller Relationships** beginning on **Page 40**.



SECTION 8: WIRING

These pages are current at the time of printing. However, in the spirit of improvement, we may make changes to the electrical systems of future machines. Compare the manufacture date of your machine to the one stated in this manual, and study this section carefully.

If there are differences between your machine and what is shown in this section, call Technical Support at (570) 546-9663 for assistance BEFORE making any changes to the wiring on your machine. An updated wiring diagram may be available. **Note:** *Please gather the serial number and manufacture date of your machine before calling. This information can be found on the main machine label.*

WARNING

Wiring Safety Instructions

SHOCK HAZARD. Working on wiring that is connected to a power source is extremely dangerous. Touching electrified parts will result in personal injury including but not limited to severe burns, electrocution, or death. Disconnect the power from the machine before servicing electrical components!

MODIFICATIONS. Modifying the wiring beyond what is shown in the diagram may lead to unpredictable results, including serious injury or fire. This includes the installation of unapproved after-market parts.

WIRE CONNECTIONS. All connections must be tight to prevent wires from loosening during machine operation. Double-check all wires disconnected or connected during any wiring task to ensure tight connections.

CIRCUIT REQUIREMENTS. You MUST follow the requirements at the beginning of this manual when connecting your machine to a power source.

WIRE/COMPONENT DAMAGE. Damaged wires or components increase the risk of serious personal injury, fire, or machine damage. If you notice that any wires or components are damaged while performing a wiring task, replace those wires or components.

MOTOR WIRING. The motor wiring shown in these diagrams is current at the time of printing but may not match your machine. If you find this to be the case, use the wiring diagram inside the motor junction box.















CAPACITORS/INVERTERS. Some capacitors and power inverters store an electrical charge for up to 10 minutes after being disconnected from the power source. To reduce the risk of being shocked, wait at least this long before working on capacitors.

EXPERIENCING DIFFICULTIES. If you are experiencing difficulties understanding the information included in this section, contact our Technical Support at (570) 546-9663.

NOTICE

The photos and diagrams included in this section are best viewed in color. You can view these pages in color at www.grizzly.com.

COLOR KEY

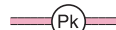
BLACK 	BLUE 	YELLOW 	LIGHT BLUE 
WHITE 	BROWN 	YELLOW GREEN 	BLUE WHITE 
GREEN 	GRAY 	PURPLE 	TURQUOISE 
RED 	ORANGE 	PINK 	



Wiring Diagram

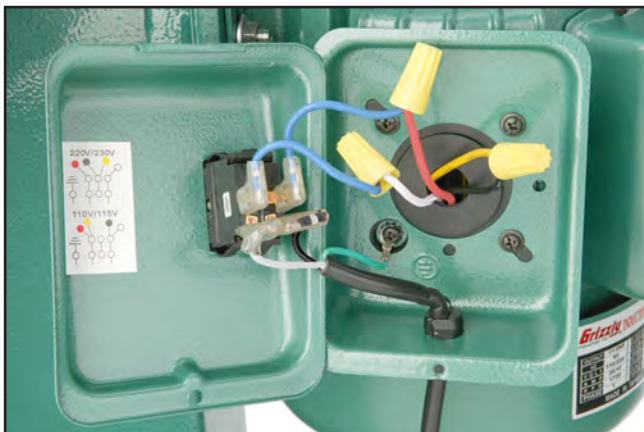
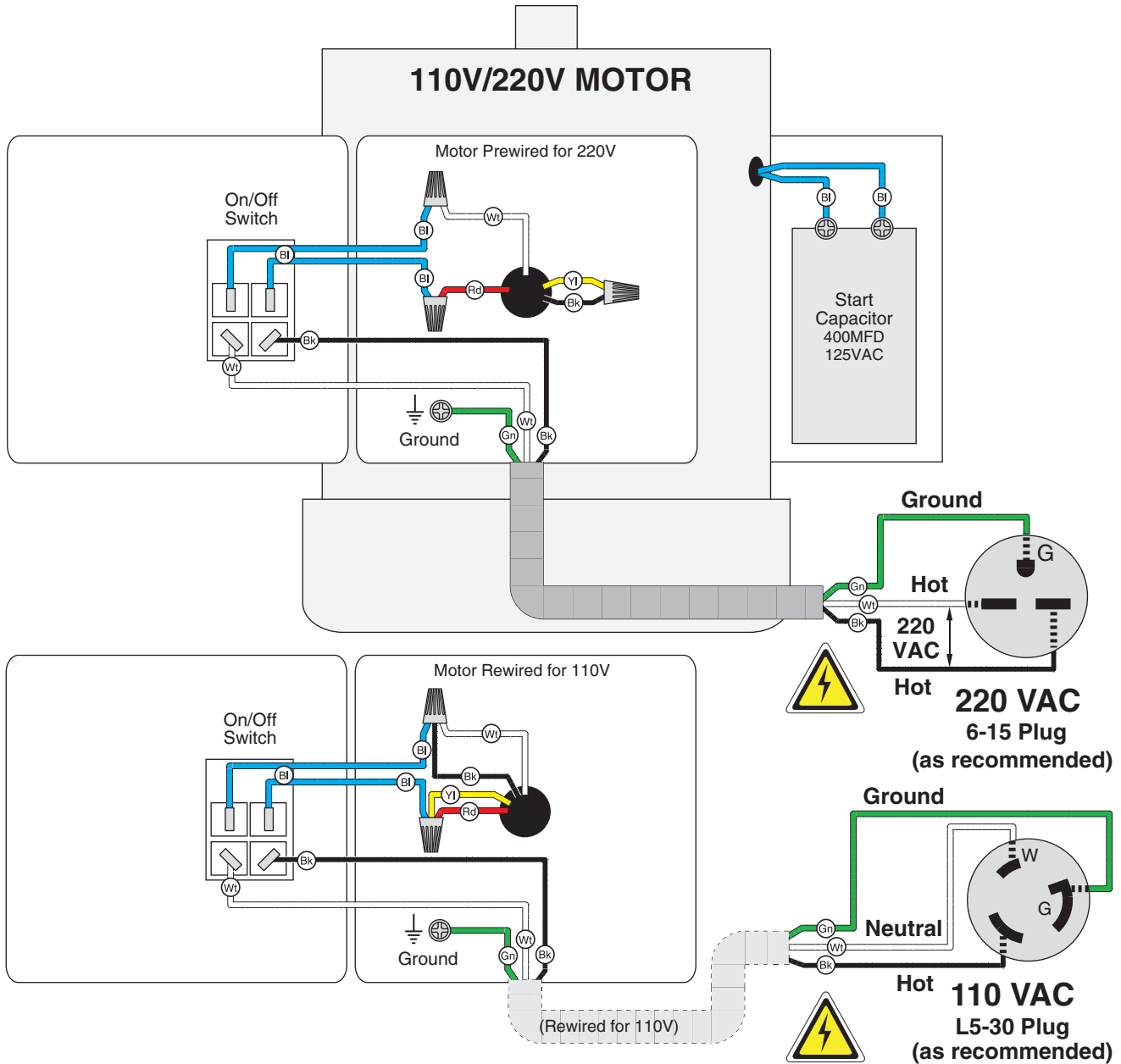

Figure 73. Motor junction box wiring (220V).



Figure 74. Start capacitor wiring.



SECTION 9: PARTS

We do our best to stock replacement parts when possible, but we cannot guarantee that all parts shown are available for purchase. Call (800) 523-4777 or visit www.grizzly.com/parts to check for availability.

Main

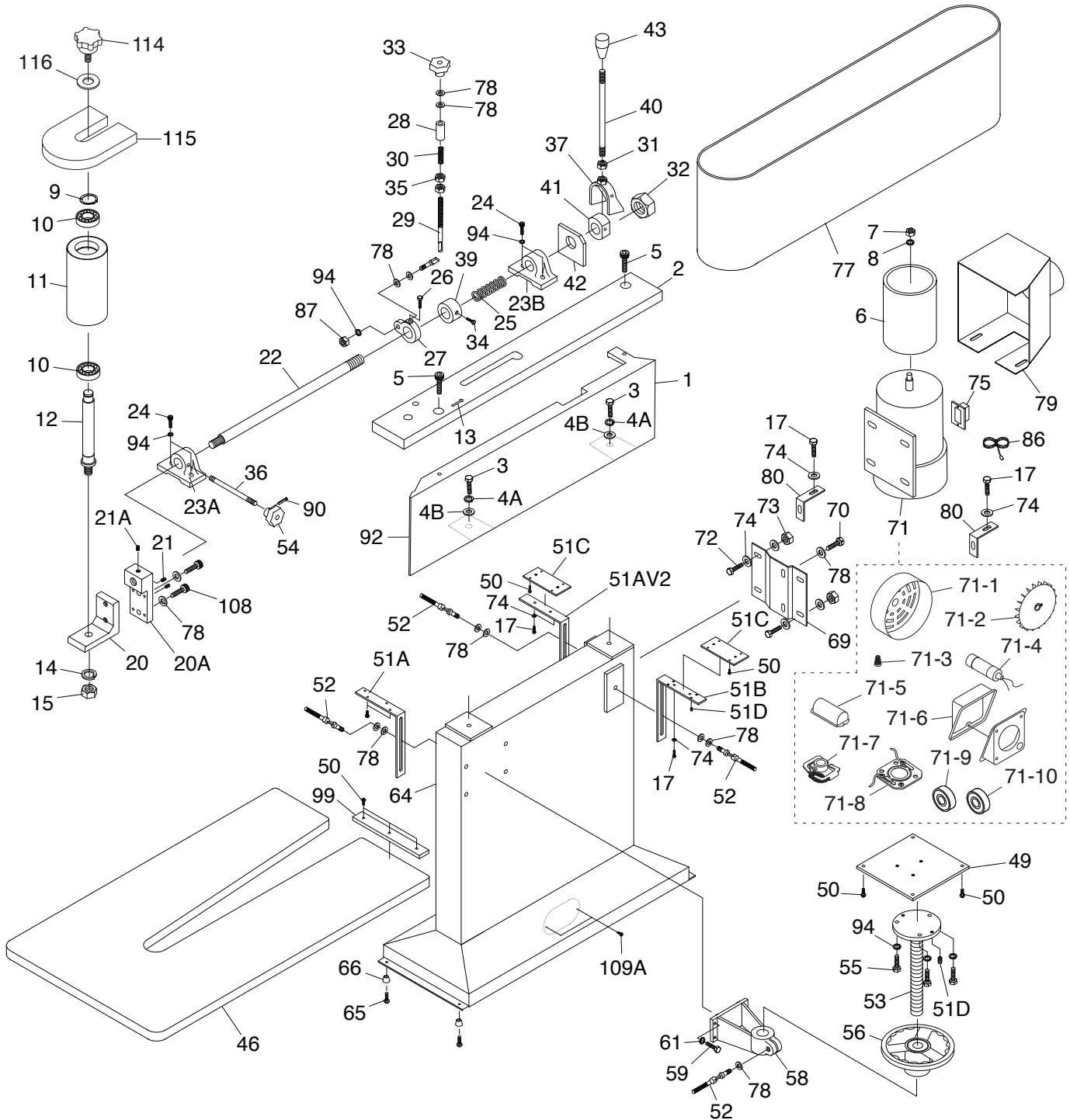

Main Parts List

REF	PART #	DESCRIPTION
1	P0512001	PLATEN
2	P0512002	PLATEN COVER
3	P0512003	HEX BOLT 3/8-16 X 1-1/2
4A	P0512004A	LOCK WASHER 10MM
4B	P0512004B	FLAT WASHER 3/8
5	P0512005	CAP SCREW 3/8-16 X 1
6	P0512006	DRIVER ROLLER
7	P0512007	HEX NUT 5/8-18
8	P0512008	LOCK WASHER 16MM
9	P0512009	EXT RETAINING RING 19MM
10	P0512010	BALL BEARING R12-Z
11	P0512011	RUBBER IDLER ROLLER
12	P0512012	ROLLER AXLE
13	P0512013	BELT DIRECTION ARROW
14	P0512014	LOCK WASHER 16MM
15	P0512015	HEX NUT 5/8-11
17	P0512017	HEX BOLT 5/16-18 X 1/2
20	P0512020	ROLLER SUPPORT BRACKET
20A	P0512020A	ROLLER BLOCK BRACKET
21	P0512021	SET SCREW 1/4-20 X 5/8
21A	P0512021A	ROLLER BRACKET SCREW 1/4-20 X 5/8
22	P0512022	BELT ADJUST SHAFT
23A	P0512023A	ADJUST SHAFT SLIDE (A)
23B	P0512023B	ADJUST SHAFT SLIDE (B)
24	P0512024	CAP SCREW 5/16-18 X 1
25	P0512025	SPRING 36 X 78
26	P0512026	HEX BOLT 5/16-18 X 3/4
27	P0512027	ARM CONTROL CASTING
28	P0512028	SLEEVE
29	P0512029	CONTROL SHAFT
30	P0512030	SPRING 16.5 X 44
31	P0512031	HEX NUT 1/2-13
32	P0512032	HEX NUT 1-8
33	P0512033	TILT KNOB 3/8"
34	P0512034	HEX BOLT 3/8-16 X 3/4
35	P0512035	HEX NUT 3/8-16
36	P0512036	STUD-UDE 3/8-16 X 5-1/2, 1, 9/16
37	P0512037	SWIVEL ASSEMBLY
39	P0512039	COLLAR
40	P0512040	LEVER
41	P0512041	SWIVEL ASSEMBLY
42	P0512042	PLATE
43	P0512043	HANDLE 1/2"
46	P0512046	TABLE
49	P0512049	PARTITION
50	P0512050	TAP SCREW #8 X 3/4
51A	P0512051A	TABLE SUPPORT BRACKET (A)

REF	PART #	DESCRIPTION
51AV2	P0512051AV2	TABLE SUPPORT BRACKET (A) V2.12.22
51B	P0512051B	TABLE SUPPORT BRACKET (B)
51C	P0512051C	ADJUSTMENT PLATE
51D	P0512051D	SET SCREW 5/16-18 X 3/8
52	P0512052	SWIVEL LOCK HANDLE 3/8-16 X 1-1/4
53	P0512053	LEADSCREW 1-4 X 228
54	P0512054	KNOB 3/8"
55	P0512055	HEX BOLT 5/16-18 X 5/8
56	P0512056	HAND WHEEL
58	P0512058	SPLIT CASTING
59	P0512059	HEX BOLT 3/8-16 X 1
61	P0512061	LOCK WASHER 10MM
64	P0512064	STAND
65	P0512065	PHLP HD SCR 10-24 X 5/8
66	P0512066	RUBBER FOOT
69	P0512069	MOTOR BRACKET
70	P0512070	HEX BOLT 3/8-16 X 1
71	P0512071	MOTOR 1.5HP 110V/220V 1-PH
71-1	P0512071-1	MOTOR FAN COVER
71-2	P0512071-2	MOTOR FAN
71-3	P0512071-3	MOTOR WIRING CAP
71-4	P0512071-4	S CAPACITOR 400M 125V 2 X 3-1/2
71-5	P0512071-5	CAPACITOR COVER
71-6	P0512071-6	MOTOR JUNCTION BOX
71-7	P0512071-7	CENT SWITCH 5/8 1725
71-8	P0512071-8	CONTACT PLATE 27 X 70 EXT
71-9	P0512071-9	BALL BEARING 6205-2RS (FRONT)
71-10	P0512071-10	BALL BEARING 6203-2RS (REAR)
72	P0512072	HEX BOLT 5/16-18 X 1-1/4
73	P0512073	HEX NUT 5/16-18
74	P0512074	FLAT WASHER 5/16
75	P0512075	ON/OFF SWITCH
77	P0512077	SANDING BELT 6" X 80" A/O 60-G (2 PK)
78	P0512078	FLAT WASHER 3/8
79	P0512079	DUST COLLECTION HOOD
80	P0512080	HOOD SUPPORT BRACKET
86	P0512086	POWER CORD 16G 3W 72"
87	P0512087	HEX NUT 3/8-16
90	P0512090	ROLL PIN 3 X 14
92	P0512092	GRAPHITE PAD 6 X 31"
94	P0512094	LOCK WASHER 8MM
99	P0512099	BACK STOP
108	P0512108	CAP SCREW 3/8-16 X 1-1/2
109A	P0512109A	TAP SCREW #8 X 5/8
114	P0512114	STAR KNOB SMALL
115	P0512115	IDLER ROLLER COVER
116	P0512116	FLAT WASHER 1/4



Labels & Cosmetics

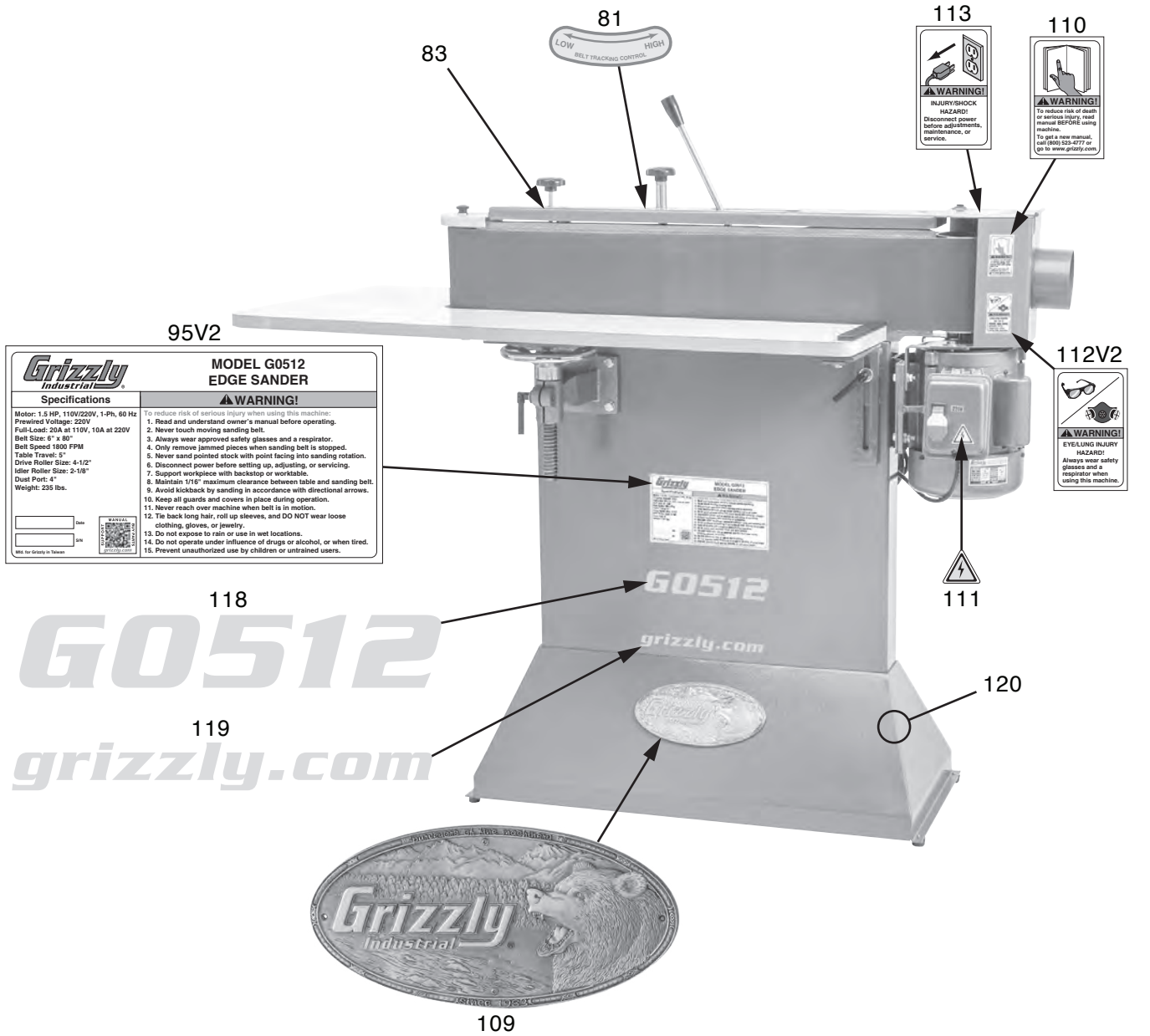

Grizzly Industrial		MODEL G0512 EDGE SANDER
Specifications	⚠️ WARNING!	
Motor: 1.5 HP, 110V/220V, 1-Ph, 60 Hz Pre-wired Voltage: 220V Full-Load: 20A at 110V, 10A at 220V Belt Size: 6" x 80" Belt Speed: 1800 FPM Table Travel: 5" Drive Roller Size: 4-1/2" Idler Roller Size: 2-1/8" Dust Port: 4" Weight: 235 lbs.	To reduce risk of serious injury when using this machine: 1. Read and understand owner's manual before operating. 2. Never touch moving sanding belt. 3. Always wear approved safety glasses and a respirator. 4. Only remove jammed pieces when sanding belt is stopped. 5. Never sand pointed stock with point facing into sanding rotation. 6. Disconnect power before setting up, adjusting, or servicing. 7. Support workpiece with backstop or worktable. 8. Maintain 1/16" maximum clearance between table and sanding belt. 9. Avoid kickback by sanding in accordance with directional arrows. 10. Keep all guards and covers in place during operation. 11. Never reach over machine when belt is in motion. 12. Tie back long hair, roll up sleeves, and DO NOT wear loose clothing, gloves, or jewelry. 13. Do not expose to rain or use in wet locations. 14. Do not operate under influence of drugs or alcohol, or when tired. 15. Prevent unauthorized use by children or untrained users.	
Date: _____ SN: _____		
<small>Mfg. for Grizzly in Taiwan</small>		

REF	PART #	DESCRIPTION
81	P0512081	TRACKING ARROW LABEL
83	P0512083	TRACKING LOCK LABEL
95V2	P0512095V2	MACHINE ID LABEL V2.11.17
109	P0512109	GRIZZLY LOGO PLATE
110	P0512110	READ MANUAL LABEL
111	P0512111	ELECTRICITY LABEL

REF	PART #	DESCRIPTION
112V2	P0512112V2	SAFETY GLASSES/RESPIRATOR LABEL V2.11.17
113	P0512113	DISCONNECT POWER LABEL
118	P0512118	MODEL NUMBER LABEL
119	P0512119	GRIZZLY.COM LABEL
120	P0512120	TOUCH-UP PAINT, GRIZZLY GREEN

⚠️ WARNING

Safety labels help reduce the risk of serious injury caused by machine hazards. If any label comes off or becomes unreadable, the owner of this machine **MUST** replace it in the original location before resuming operations. For replacements, contact (800) 523-4777 or www.grizzly.com.



WARRANTY & RETURNS

Grizzly Industrial, Inc. warrants every product it sells for a period of **1 year** to the original purchaser from the date of purchase. This warranty does not apply to defects due directly or indirectly to misuse, abuse, negligence, accidents, repairs or alterations or lack of maintenance. This is Grizzly's sole written warranty and any and all warranties that may be implied by law, including any merchantability or fitness, for any particular purpose, are hereby limited to the duration of this written warranty. We do not warrant or represent that the merchandise complies with the provisions of any law or acts unless the manufacturer so warrants. In no event shall Grizzly's liability under this warranty exceed the purchase price paid for the product and any legal actions brought against Grizzly shall be tried in the State of Washington, County of Whatcom.

We shall in no event be liable for death, injuries to persons or property or for incidental, contingent, special, or consequential damages arising from the use of our products.

The manufacturers reserve the right to change specifications at any time because they constantly strive to achieve better quality equipment. We make every effort to ensure that our products meet high quality and durability standards and we hope you never need to use this warranty.

In the event you need to use this warranty, contact us by mail or phone and give us all the details. We will then issue you a "Return Number," which must be clearly posted on the outside as well as the inside of the carton. We will not accept any item back without this number. Proof of purchase must accompany the merchandise.

Please feel free to write or call us if you have any questions about the machine or the manual.

Thank you again for your business and continued support. We hope to serve you again soon.

For further information about the warranty, visit <https://www.grizzly.com/forms/warranty> or scan the QR code below to be automatically directed to our warranty page.



grizzly.com[®]

TOOL WEBSITE

Buy Direct and Save with Grizzly[®] – Trusted, Proven and a Great Value!
~Since 1983~

*Visit Our Website Today For
Current Specials!*

**ORDER
24 HOURS A DAY!
1-800-523-4777**

